

19"~23.8" G-WIN Panel PC HMI

Intel® Core™ i5-1135G7 (8M Cache, up to 4.20 GHZ without V Pro)

Intel® Core™ i5-1145G7 (8M Cache, up to 4.20 GHZ with V Pro)



Model No. R19IT7T-GCM1
W22IT7T-GCA3
W24IT7T-GCA2

GC Series

User Manual

Contents

Preface	3
About This User Manual	6
Chapter 1: Introduction	7
1.1 Introduction	7
1.2 Features.....	7
1.3 Package Content.....	8
1.4 Product Overview.....	9
1.5 Physical Buttons and LED Indicators.....	12
Chapter 2: Getting Started	13
2.1 Wiring Requirements.....	13
2.2 Turning On and Off Your Device	14
2.3 Connecting to Other Devices	15
2.3.1 Connector Description.....	15
2.3.2 Dimming Knob	15
Chapter 3: Mounting	16
3.1 VESA Mount	16
3.2 Panel Mount.....	16
Chapter 4: Operating the Device	17
4.1 Operating System	17
4.2 Multi-Touch	17
4.3 How to Enable Watchdog.....	18
Chapter 5: Insyde BIOS Setup	19
5.1 How and When to Use BIOS Setup.....	19
5.2 BIOS Functions.....	21
5.2.1 Main Menu.....	21
5.2.2 Advanced	22
5.2.3 Security	46
5.2.4 Power	47
5.2.5 Boot	48
5.2.6 Exit	49
5.3 Using Recovery Wizard to Restore Computer	50
Chapter 6: Driver Installation	51
6.1 Chipset Driver	51
6.2 Graphic Driver.....	54
6.3 Management Engine (ME)	58
6.4 Audio Driver	60
6.5 Ethernet Driver.....	62
6.6 Watchdog Driver Installation	65
6.7 Digital IO Driver Installation	68

Chapter 7: Technical Support	71
7.1 Software Developer Support	71
7.2 Problem Report Form.....	72
Appendix	73
Appendix A: Product Specifications.....	73

Preface

FCC Statement



This device complies with part 15 FCC rules.

Operation is subject to the following two conditions:

- This device may not cause harmful interference.

This device must accept any interference received including interference that may cause undesired operation.

This equipment has been tested and found to comply with the limits for a class "B" digital device, pursuant to part 15 of the FCC rules. These limits are designed to provide reasonable protection against harmful interference when the equipment is operated in a commercial environment. This equipment generates, uses, and can radiate radio frequency energy and, if not installed and used in accordance with the instruction manual, may cause harmful interference to radio communications. Operation of this equipment in a residential area is likely to cause harmful interference in which case the user will be required to correct the interference at his own expense.

European Union

This equipment is in conformity with the requirement of the following EU legislations and harmonized standards. Product also complies with the Council directions.



Electromagnetic Compatibility Directive (2014/30/EU)

- EN55024: 2010/ A1: 2015
 - IEC61000-4-2: 2009
 - IEC61000-4-3: 2006+A1: 2007+A2: 2010
 - IEC61000-4-4: 2012
 - IEC61000-4-5: 2014
 - IEC61000-4-6: 2014
 - IEC61000-4-8: 2010
 - IEC61000-4-11: 2004
- EN55032: 2012/AC:2013
- EN61000-3-2:2014
- EN61000-3-3:2013

Low Voltage Directive (2014/35/EU)

- EN 60950-1:2006/A11:2009/A1:2010/A12:2011/ A2:2013

Copyright Notice

No part of this document may be reproduced, copied, translated, or transmitted in any form or by any means, electronic or mechanical, for any purpose, without the prior written permission of the original manufacturer.

Trademark Acknowledgement

Brand and product names are trademarks or registered trademarks of their respective owners.

Disclaimer

Winmate Inc. reserve the right to make changes, without notice, to any product, including circuits and/or software described or contained in this manual in order to improve design and/or performance. We assume no responsibility or liability for the use of the described product(s) conveys no license or title under any patent, copyright, or masks work rights to these products, and make no representations or warranties that these products are free from patent, copyright, or mask work right infringement, unless otherwise specified. Applications that are described in this manual are for illustration purposes only. We make no representation or guarantee that such application will be suitable for the specified use without further testing or modification.

Warranty

Winmate Inc. warranty guarantees that each of its products will be free from material and workmanship defects for a period of one year from the invoice date. If the customer discovers a defect, we will, at his/her option, repair or replace the defective product at no charge to the customer, provide it is returned during the warranty period of one year, with transportation charges prepaid. The returned product must be properly packaged in its original packaging to obtain warranty service. If the serial number and the product shipping data differ by over 30 days, the in-warranty service will be made according to the shipping date. In the serial numbers the third and fourth two digits give the year of manufacture, and the fifth digit means the month (e. g., with A for October, B for November and C for December).

For example, the serial number 1W16Axxxxxxx means October of year 2016.

Customer Service

We provide a service guide for any problem by the following steps: First, visit the website of our distributor to find the update information about the product. Second, contact with your distributor, sales representative, or our customer service center for technical support if you need additional assistance.

You may need the following information ready before you call:

- Product serial number
- Software (OS, version, application software, etc.)
- Description of complete problem
- The exact wording of any error messages

In addition, free technical support is available from our engineers every business day. We are always ready to give advice on application requirements or specific information on the installation and operation of any of our products.

Advisory Conventions

Four types of advisories are used throughout the user manual to provide helpful information or to alert you to the potential for hardware damage or personal injury. These are Notes, Important, Cautions, and Warnings. The following is an example of each type of advisory.



Note:

A note is used to emphasize helpful information



Important:

An important note indicates information that is important for you to know.



Caution A Caution alert indicates potential damage to hardware and explains how to avoid the potential problem.

Attention Une alerte d'attention indique un dommage possible à l'équipement et explique comment éviter le problème potentiel.



Warning! An Electrical Shock Warning indicates the potential harm from electrical hazards and how to avoid the potential problem.

Avertissement! Un Avertissement de Choc Électrique indique le potentiel de chocs sur des emplacements électriques et comment éviter ces problèmes.



Alternating Current

The Protective Conductor Terminal (Earth Ground) symbol indicates the potential risk of serious electrical shock due to improper grounding.

Mise à le terre ! Le symbole de Mise à Terre indique le risqué potentiel de choc électrique grave à la terre incorrecte.

Safety Information



Warning! Always completely disconnect the power cord from your chassis whenever you work with the hardware. Do not make connections while the power is on. Sensitive electronic components can be damaged by sudden power surges. Only experienced electronics personnel should open the PC chassis.

Avertissement! Toujours débrancher le cordon d'alimentation du chassis lorsque vous travaillez sur celui-ci. Ne pas brancher de connections lorsque l'alimentation est présente. Des composantes électroniques sensibles peuvent être endommagées par des sauts d'alimentation. Seulement du personnel expérimenté devrait ouvrir ces chassis.



Caution Always ground yourself to remove any static charge before touching the CPU card. Modern electronic devices are very sensitive to static electric charges. As a safety precaution, use a grounding wrist strap at all times. Place all electronic components in a static-dissipative surface or static-shielded bag when they are not in the chassis.

Attention Toujours vérifier votre mise à la terre afin d'éliminer toute charge statique avant de toucher la carte CPU. Les équipements électroniques modernes sont très sensibles aux décharges d'électricité statique. Toujours utiliser un bracelet de mise à la terre comme précaution. Placer toutes les composantes électroniques sur une surface conçue pour dissiper les charge, ou dans un sac anti-statique lorsqu'elles ne sont pas dans le chassis.

General Guideline

It is recommended to reboot the device when some functions are defect or inactive. If it still can't solve the problems please contact your dealer or agent.

About This User Manual

The documentation set for the G-WIN GC-Series Panel PC with Intel® Core™ i5 processor provides information for specific user needs, and includes:

- **G-WIN GC Series Panel PC User Manual** – contains detailed description on how to use the panel PC, its components and features.



Note:

Some pictures in this guide are samples and can differ from actual product.

Document Revision History

Version	Date	Note
1.0	04-Oct-2023	Initial document release

Chapter 1: Introduction

This chapter gives you product overview, describes features and hardware specification. You will find all accessories that come with the panel PC in the packing list. Mechanical dimensions and drawings included in this chapter.

1.1 Introduction

Congratulations on purchasing Winmate® G-WIN GC Series Panel PC. The elegantly designed, yet rugged, industrial grade G-WIN GC series is designed for heavy duty applications.

With rugged construction, ultimate computing power, G-WIN GC Series Panel PC are guaranteed to meet "heavy duty" needs. This series feature high computing power and user-friendly interface with projected capacitive multi-touch (PCAP) technology and support Windows® operating systems. Rugged housing provides front IP65 protection against outer dust and water splash.

1.2 Features

Winmate® GC Series Panel PC features:

- 19"/ 21.5"/ 23.8" PCAP touchscreen
- High performance Intel® Core™ i3/i5/i7 processor
- Front IP65 for protection against water and dust
- A true flat, easy-to-clean front surface with edge-to-edge design
- Plenty of I/O, including 2 x LAN, 1 x RS232/422/485, 1 x RS232, 4 x USB 3.2 Gen 1(type A), 1 x HDMI 2.0, 1 x DP 1.4, Line-Out, Mic in
- DP Support 4096 x 2304@60Hz
- HDMI Support 4096 x 2304@24Hz

1.3 Package Content

Carefully remove the box and unpack your device. Please check if all the items listed below are inside your package. If any of these items are missing or damaged contact us immediately.

Standard factory shipment list:

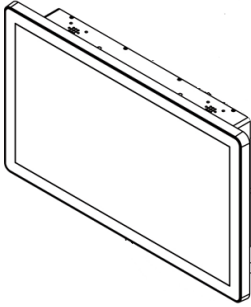

- **Panel PC**

Varies by product specifications



- **User Manual**

Part No. 91521110111V

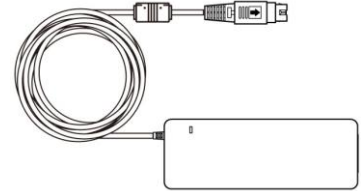

- **AC Adapter 12V/ 84W**

Part No. 922D120W12V4

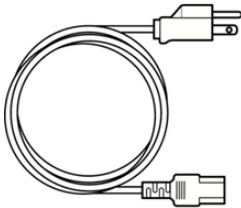

- **Power Cable**

Varies by country

1.4 Product Overview

19", R19IT7T-GCM1

Unit: mm

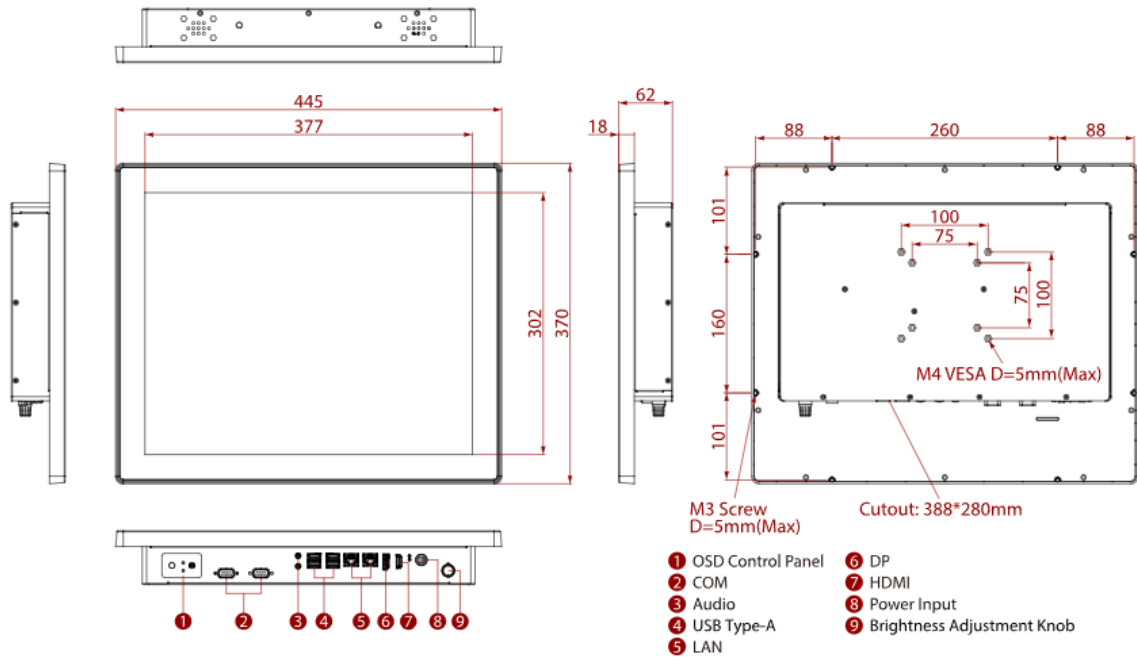

No	Description	No	Description
①	OSD Control Panel	⑥	DP 1.4
②	1 x RS-232/422/485, 1 x RS-232	⑦	HDMI 2.0
③	Mic in/ Line out	⑧	Power input
④	4 x USB 3.2 Gen1 (type-A)	⑨	Brightness Adjustment Knob
⑤	2 x Giga LAN RJ46		

21.5", W22IT7T-GCA3

Unit: mm

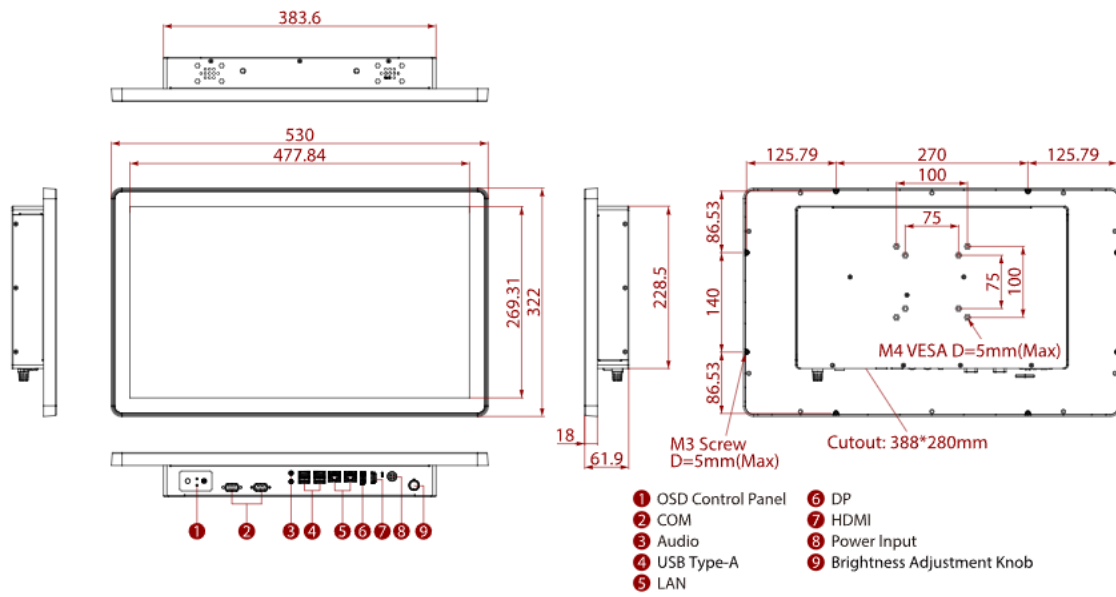

No	Description	No	Description
①	OSD Control Panel	⑥	DP 1.4
②	1 x RS-232/422/485, 1 x RS-232	⑦	HDMI 2.0
③	Mic in/ Line out	⑧	Power input
④	4 x USB 3.2 Gen1 (type-A)	⑨	Brightness Adjustment Knob
⑤	2 x Giga LAN RJ46		

23.8", W24IT7T-GCA2

Unit: mm

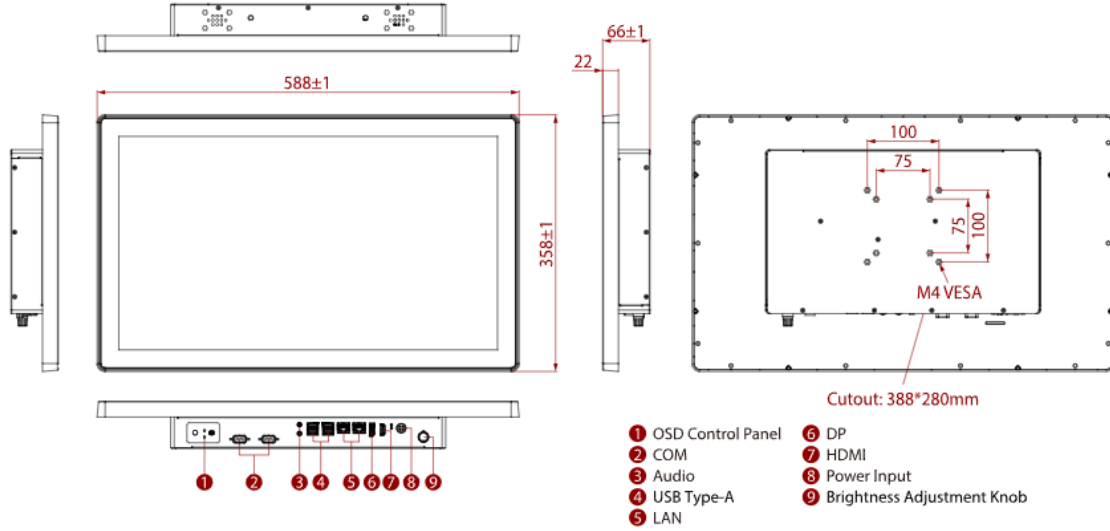



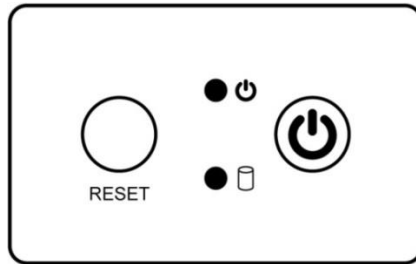

No	Description	No	Description
①	OSD Control Panel	⑥	DP 1.4
②	1 x RS-232/422/485, 1 x RS-232	⑦	HDMI 2.0
③	Mic in/ Line out	⑧	Power input
④	4 x USB 3.2 Gen1 (type-A)	⑨	Brightness Adjustment Knob
⑤	2 x Giga LAN RJ46		

1.5 Physical Buttons and LED Indicators

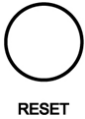
Physical buttons and LED indicators located on the rear side of the panel PC.



Physical Buttons		
Icon	Button	Description
	Reset	Press to reset the system
	Power On/ Off	Press to power on or power off the device
LED Indicators		
LED Type	Status	Description
	On	Power is on
	Off	Power is off
	Blinking	Storage activity (Data is being read or written)
	Off	System is idle

Chapter 2: Getting Started

This chapter tells you important information on power supply, adapter and precautions tips. Pay attention to power considerations.

2.1 Wiring Requirements

The following common safety precautions should be observed before installing any electronic device:



Caution

- Strive to use separate, non-intersecting paths to route power and networking wires. If power wiring and device wiring paths must cross make sure the wires are perpendicular at the intersection point.
- Keep the wires separated according to interface. The rule of thumb is that wiring that shares similar electrical characteristics may be bundled together.
- Do not bundle input wiring with output wiring. Keep them separate.
- When necessary, it is strongly advised that you label wiring to all devices in the system.
- Do not run signal or communication wiring and power wiring in the same conduit. To avoid interference, wires with different signal characteristics (i.e., different interfaces) should be routed separately.
- Be sure to disconnect the power cord before installing and/or wiring your device.
- Verify the maximum possible current for each wire gauge, especially for the power cords. Observe all electrical codes dictating the maximum current allowable for each wire gauge.
- If the current goes above the maximum ratings, the wiring could overheat, causing serious damage to your equipment.
- Be careful when handling the unit. When the unit is plugged in, the internal components generate a lot of heat which may leave the outer casing too hot to touch.

2.2 Turning On and Off Your Device

To turn on your device:

Follow the following steps to turn on your device:

1. Connect the Panel PC to a to a DIN adapter (4-pin).
2. Connect the AC adapter to the power cord.
3. Plug in the power cord to a working AC wall outlet. The device will boot automatically.

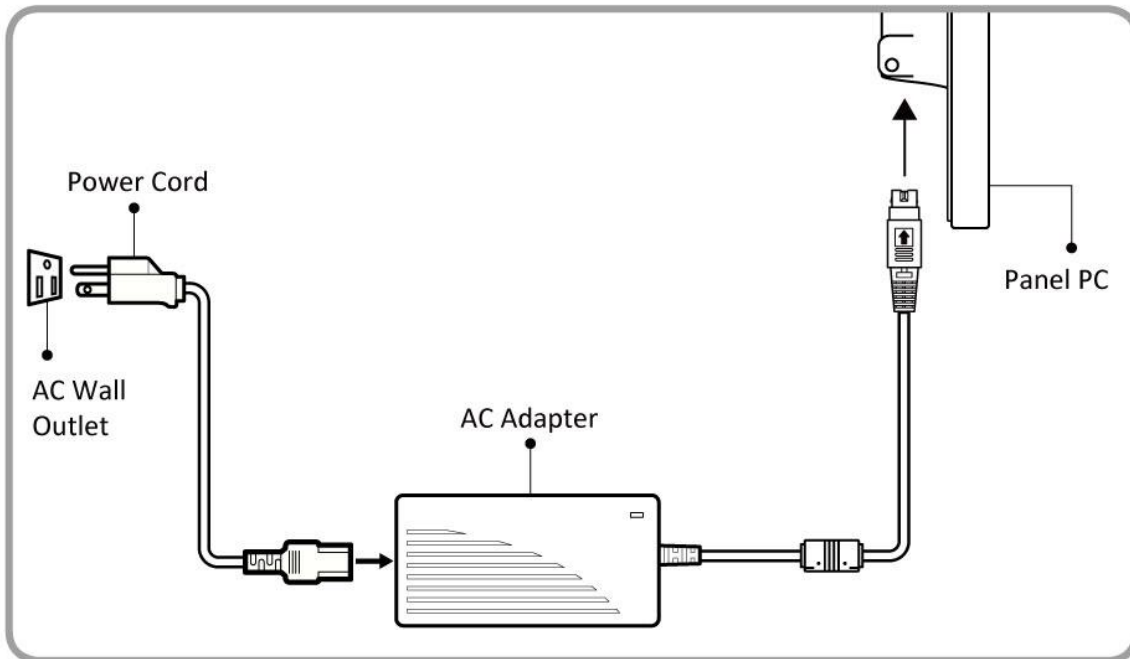

Caution Use only the AC adapter (12V/ 84W) included in your package (Rating: Output 4.2 A). Using other AC adapters may damage the device.

Attention Utilisez uniquement l'adaptateur secteur (12V / 50W) inclus dans votre emballage (puissance nominale: sortie 4,2 A). L'utilisation d'autres adaptateurs secteur peut endommager l'appareil.



Alternating Current

This product must be grounded. Use only a grounded AC outlet. Install the additional PE ground wire if the local installation regulations require it.

To shut down the device:

1. Tap **Start**  > **Shut down**.
2. Wait for your Panel PC to completely turn off before disconnecting the power cord (if necessary).

2.3 Connecting to Other Devices

This section explains how to connect external interfaces to the Panel PC.

2.3.1 Connector Description







Connectors are located on the bottom side of the panel PC.

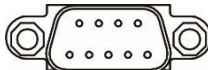
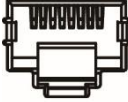

Note:

Notice that input and output connectors vary by product size and specifications.

Connector description:

Item	Description
	Power Jack 4-pin – Provides power to the panel PC, accepts 12V DC.
	Audio Jack – Connects audio equipment to panel PC, supports line-out and microphone.
	RS-232/422/485 – Connects external devices to panel PC. <i>Example: A barcode reader or scanner to panel PC.</i>
	RJ45 (LAN) – Connects panel PC to Ethernet network.
	USB 3.2 Gen 2x1 - Connects compatible devices to panel PC. <i>Example: A printer to HMI device.</i>
	HDMI 2.0 – Transmits audio/video from a panel PC to an output device. <i>Example: An external monitor to panel PC.</i>
	DisplayPort 1.4 – Transmits video from a panel PC to an output device. <i>Example: An external monitor to panel PC.</i>

2.3.2 Dimming Knob

Dimming knob is located on the back side of the panel pc. Use dimming knob to quickly adjust screen brightness.



Chapter 3: Mounting

This chapter provides mounting guide for all available mounting options. Pay attention to cautions and warning to avoid any damages.

3.1 VESA Mount

This device supports VESA Mounting and provides various types of mounting options to fit any industrial use or vehicle.

Size	VESA Plate
19", 21.5", 23.8"	75x75 mm, 100x100 mm

Mounting Instruction

1. Use Philips M4x5 screws to fix the desk stand to VESA holes on the back cover of the device.
2. Follow installation instructions supplied with your VESA Mount accessories.

**The picture is for demonstration purposes only. VESA Mount accessories are not supplied by Winmate.*

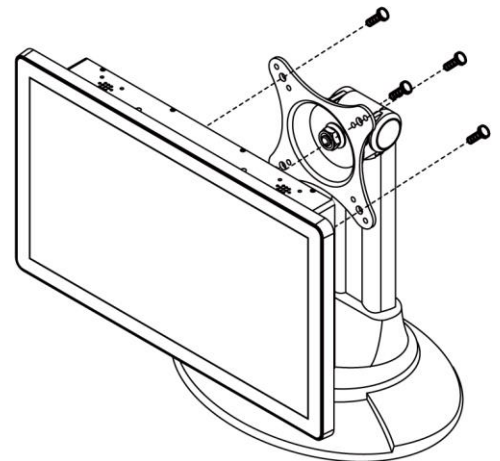

3.2 Panel Mount

Panel Mount mounting solutions is suitable for many applications where Panel PC should be embedded. With this mounting solution flat surface leave no bezel in the front.

Size	Wall Cutout	Screw Hole Diameter
19"	388 x 280 mm	M4 x 5 mm
21.5"	388 x 280 mm	M4 x 5 mm
23.8"	388 x 280 mm	M4 x 5 mm

Mounting Instruction:

1. Prepare a fixture for the specific dimensions of the device.
2. Cut a hole on a sub frame or panel according to the cutout dimensions.
3. Install the device properly onto the cutout area of the sub frame or panel with the sides of the front bezel.
4. Fix the device to fixture with Phillips screws.

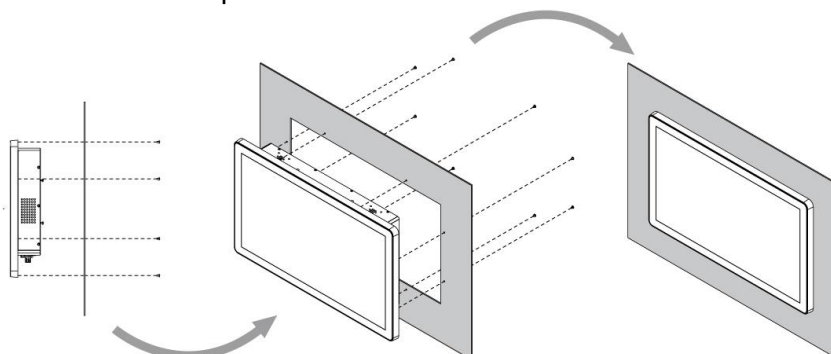

Chapter 4: Operating the Device







In this chapter you will find instructions on how to operate the device.

4.1 Operating System

The Panel PCs supports Windows 10 IoT Enterprise operating system.

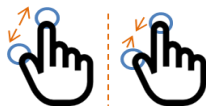
4.2 Multi-Touch

The touch screen supports the core gestures for Windows.



Gesture	Windows Usage	Gesture Action	Action
Tap/ Double-tap	Click / Double-click	Click or double-click	
Panning with Inertia	Scrolling	Drag one or two fingers up and down	
Selection/Drag (left to right with one finger)	Mouse-drag/ Selection	Drag one finger left/right	
Zoom	Zoom (default to CTRL key + scroll wheel)	Move two fingers apart/ toward each other	
Rotate	No system default unless handled by Application (using WM_Gesture API)	Move two fingers in opposite directions <i>or</i> Use one finger to pivot around another	
Press and Hold	Right-click	Press, wait for blue-ring animation to complete, then release	
Flicks	Default: Pan Up/ Down/ Back, and Forward	Make quick drag gestures in the described direction	

*Reference from Microsoft®

4.3 How to Enable Watchdog

To enable Watchdog, you need to download Winmate Watchdog utility. Find more information on Watchdog in “Watchdog Guide” that you can download from Winmate Download Center or File Share.

To enable watchdog in Watchdog AP follow the instructions below:

1. On the right bottom side of the desktop screen, click  **triangle button** to show hidden icons.
2. Click  icon to open Watchdog utility.

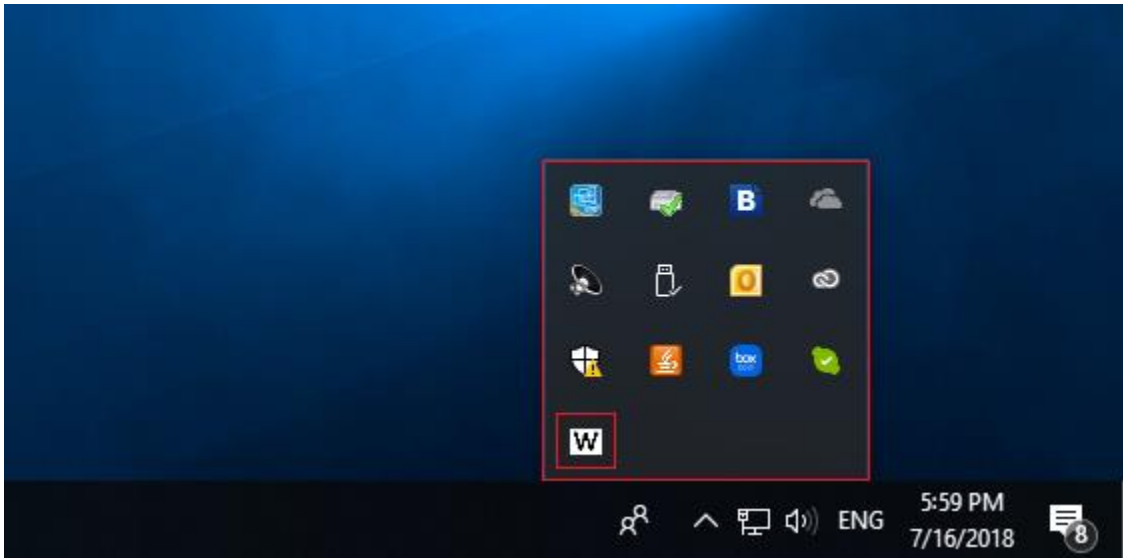

3. In Watchdog utility window set countdown time and periodically feed time, or disable watchdog.

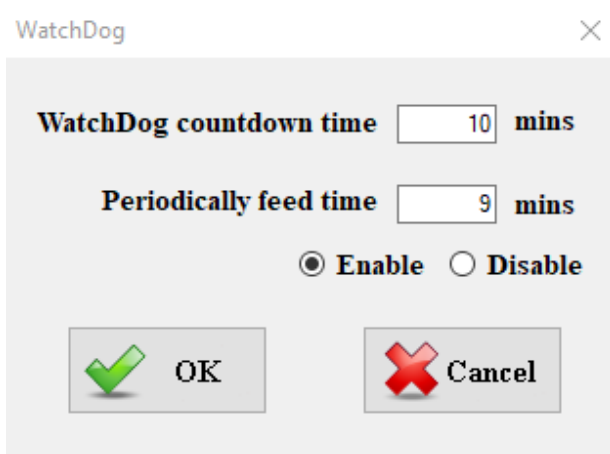

Example:

Every 10 min watchdog will monitor the system, in case any error occurs the system will restart automatically when the countdown time reaches 0.

Every 9 min watchdog timer will be reset to 10 min.

Settings	Description
Watchdog Countdown Time	The system automaticity restarts when this countdown time reaches zero. <i>Default: 10 min</i>
Periodically Feed Time	To set a cycle time to automatically reset watchdog timer. <i>Default: 9 min</i>
Enable / Disable	Enable or disable watchdog. <i>Default: Enable</i>

Chapter 5: Inside BIOS Setup

BIOS Setup Utility is a program for configuration basic Input / Output system settings of the computer for optimum use. This chapter provides information on how to use BIOS setup, its functions and menu.

5.1 How and When to Use BIOS Setup

To enter the BIOS setup, you need to connect an external USB keyboard, external monitor and press Del key when the prompt appears on the screen during start up. The prompt screen shows only few seconds so need press Del key quickly.



Important:

Updated BIOS version may be published after the manual released. Check the latest version of BIOS on the website.

You may need to run BIOS setup utility for reasons listed below:

1. Error message on screen indicates to check BIOS setup
2. Restoring the factory default settings.
3. Modifying the specific hardware specifications
4. Necessity to optimize specifications

BIOS Navigation Keys

The following keys are enabled during POST:

Key	Function
Del	Enters the BIOS setup menu.
F7	Display the boot menu. Lists all bootable devices that are connected to the system. With cursor ↑ and cursor ↓ and by pressing <ENTER>, select the device used for the boot.
Pause	Pressing the [Pause] key stops the POST. Press any other key to resume the POST.

The following Keys can be used after entering the BIOS Setup.

Key	Function
F1	Help
F5/ F6	Change Values
F9	Setup Defaults
F10	Save & Exit
Esc	Exit
Enter	Select SubMenu
↑/ ↓	Select Item
← / →	Select Item

For items marked ► press <Enter> for more options.



Note:

You can press the F1, F2, F3, F4, -/+, and Esc keys by connecting a USB keyboard to your computer.

5.2 BIOS Functions

5.2.1 Main Menu

The Main menu displays the basic information about your system including BIOS version, processor RC version, system language, time, and date.

When you enter BIOS setup, the first menu that appears on the screen is the main menu. It contains the system information including BIOS version, processor RC version, system language, time, and date.

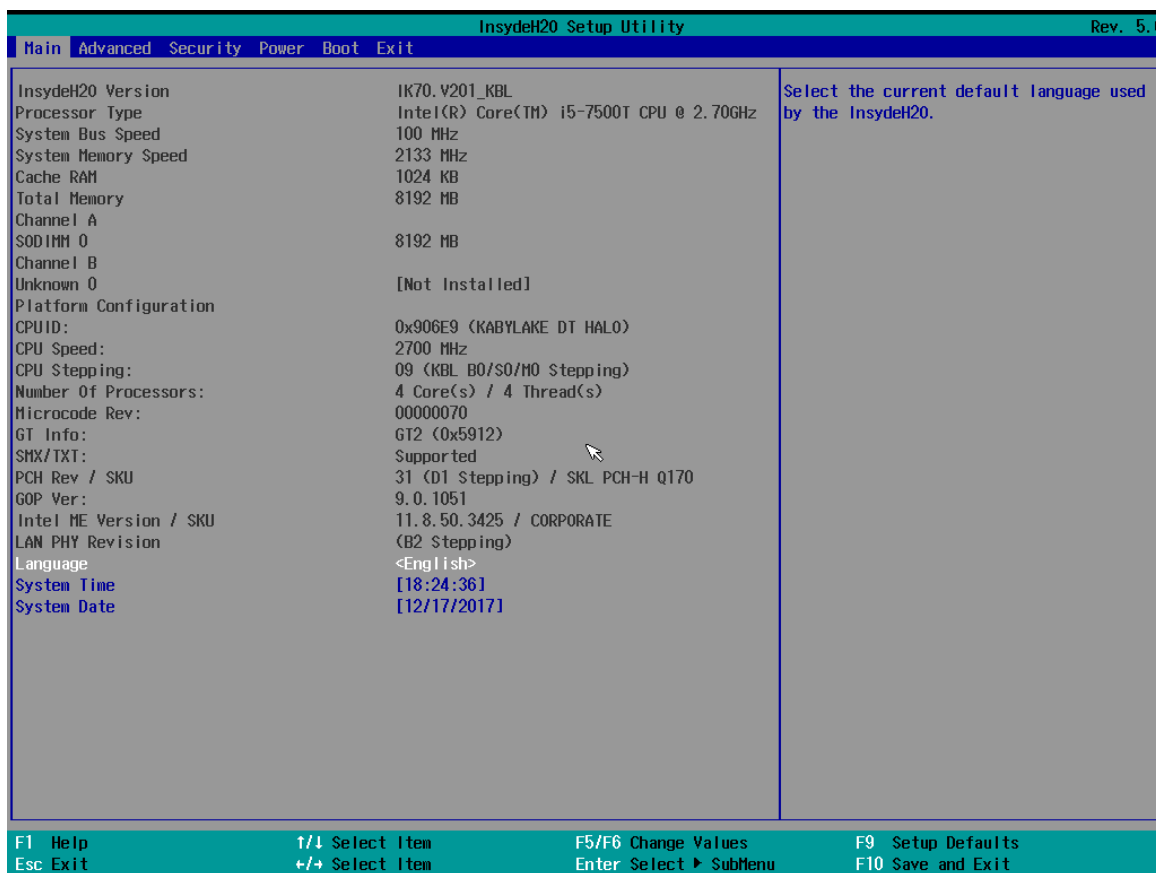

BIOS Setting	Description	Setting Option	Effect
Language	Displays the system language. [English] is set up by default.	Adjustment of the language	Set the language in other language. The language in this device is English.
System Time	This is current time setting. The time is maintained by the battery when the device is turned off.	Date and time changes.	Set the time in the format: [hh/mm/ss]
System Date	This is current date setting.	Date and time changes.	Set the date in the format [mm/dd/yyyy];

5.2.2 Advanced

Select the Advanced Tab from the setup menu to enter the advanced BIOS setup screen. You can select any of the items on the left frame of the screen to go to the sub menu for the item, such as CPU Configuration. You can use the <Arrow> keys enter all advanced BIOS setup options. The advanced BIOS setup menu is shown below. The submenus described on the following pages.



Caution Handle advanced BIOS settings page with caution. Any changes can affect the operation of your computer

Attention Manipulez la page des paramètres avancés du BIOS avec prudence. Toute modification peut affecter le fonctionnement de votre ordinateur.

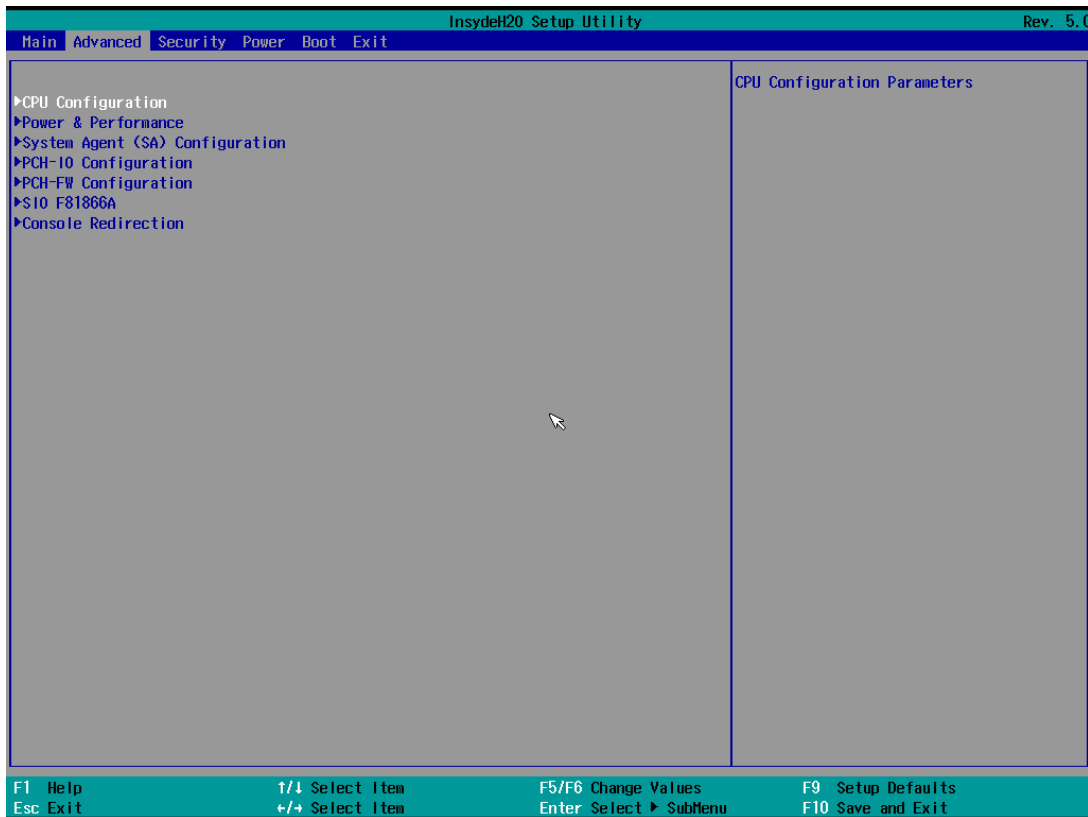

BIOS Setting	Description	Setting Option	Effect
CPU Configuration	Configures Trusted Computing parameters	Enter	Opens submenu
Power & Performance	Configures Power & Performance parameters	Enter	Opens submenu
System Agent Configuration	Configures System Agent Configuration parameters	Enter	Opens submenu
PCH-OI Configuration	Configures PCH-OI parameters	Enter	Opens submenu
PCH-FM Configuration	Configures PCH-FM parameters	Enter	Opens submenu
SIO F81866A	Configures SIO F81866A parameters	Enter	Opens submenu
Console Redirection	Configures Console Redirection parameters	Enter	Opens submenu

5.2.2.1 CPU Configuration

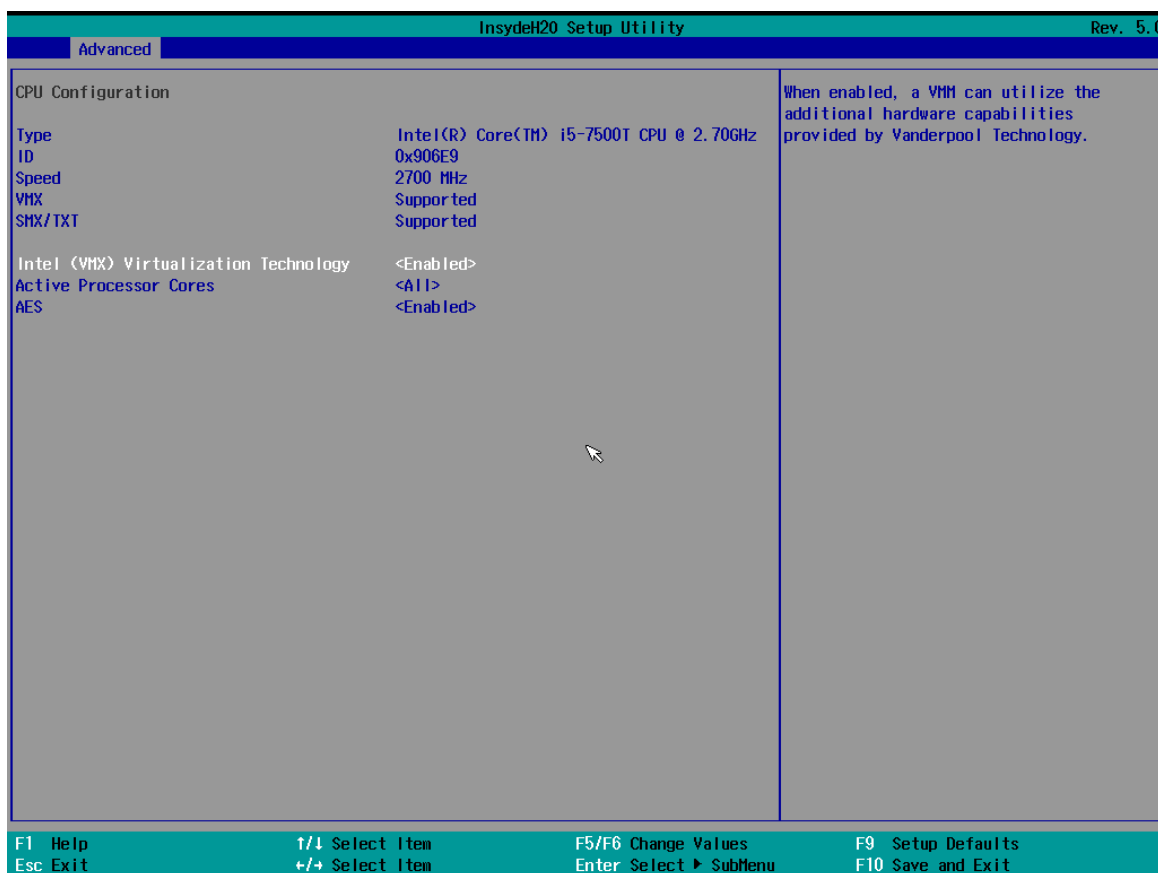

BIOS Setting	Description	Setting Option	Effect
Intel (VMM) Virtualization Technology	Enable or disable Intel Virtualization Technology.	Enable/Disable	When enabled, a VMM can utilized the additional hardware capabilities provided by Vanderpool Technology.
Active Processor Cores	Number of core to enable in each processor package	All / 1 / 2 / 3	Select number of core to enable in each processor package
AES	Enable or disable AES (Advanced Encyption Standard)	Enable/Disable	Enable or disable AES

5.2.2.2 Power & Performance

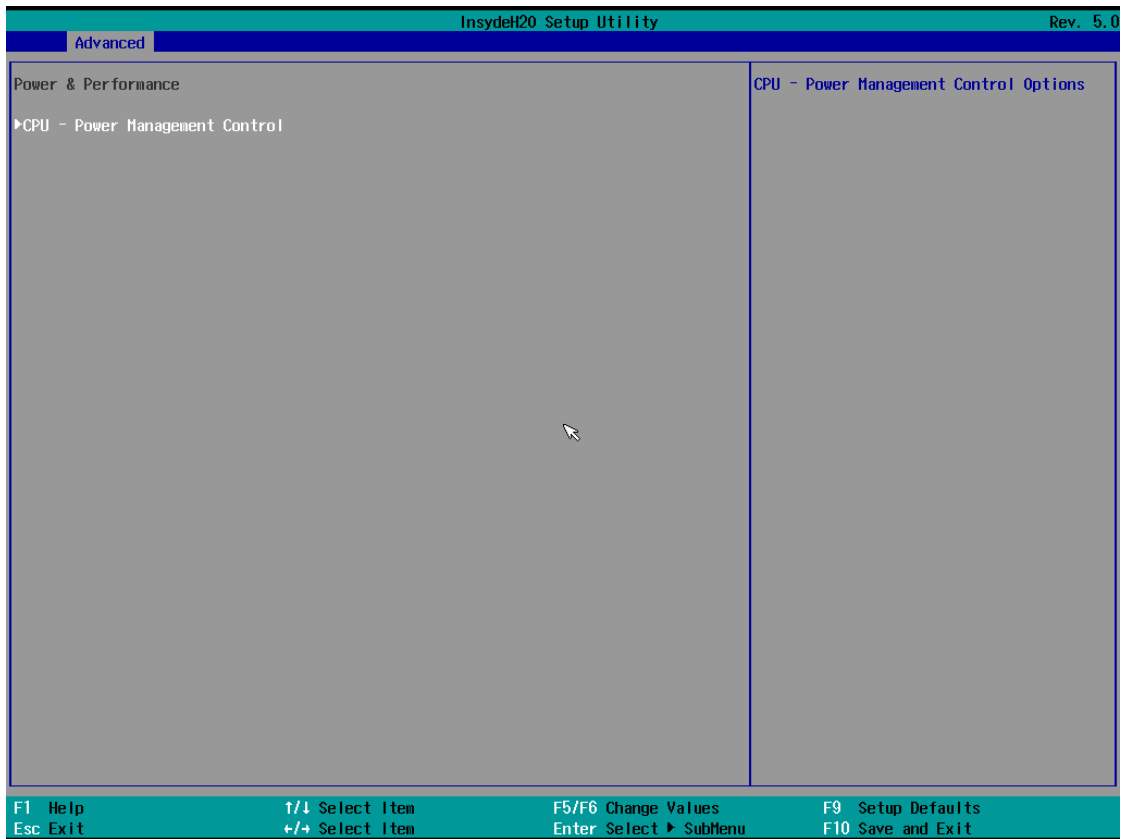

BIOS Setting	Description	Setting Option	Effect
CPU – Power Management Control	Configure CPU – Power Management Control parameters	Enter	Enters sub-menu

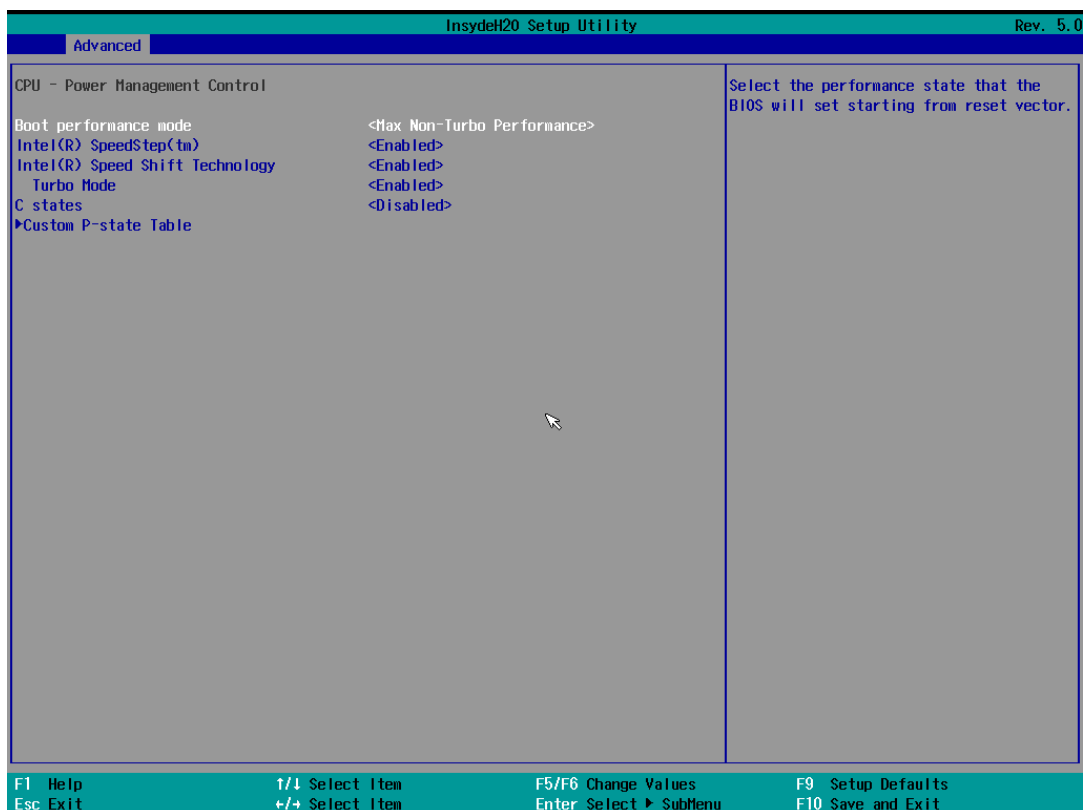

BIOS Setting	Description	Setting Option	Effect
Boot Performance Mode	Configure Boot Performance Mode parameters	-Max non-turbo performance -Max battery -Turbo Performance	Select the performance state that the BIOS will set starting from reset vector
Intel SpeedStep (ta)	Configure Intel SpeedStep (ta) parameters	Enabled/ Disabled	Allows more than two frequency ranges to be supported
Intel Speed Shift Technology	Configure Intel Speed Shift Technology parameters	Enabled/ Disabled	Enable/ Disable Intel Speed Shift Technology support. Enabling will expose the CPP v2 interface to allow for hardware controlled P-states
-Turbo Mode	Enable or disable Turbo Mode	Enabled/ Disabled	Enable/ Disable processor Turbo Mode (requires EMTTM enabled too). Auto means enabled, unless max turbo ratio is bigger than 16 – SKL AO W/A
C states	Enable or disable C states	Enabled/ Disabled	Enable/ Disable CPU Power Management. Allows COU to go to C states when it is not 100% utilized
Custom P-state Table	Configure Custom P-state Table parameters	Enter	Enters sub-menu
-Number of P-states	Select the number of custom P-states.	[Number]	Set the number of custom P-states. At least 2 states must be present

5.2.2.3 System Agent (SA) Configuration

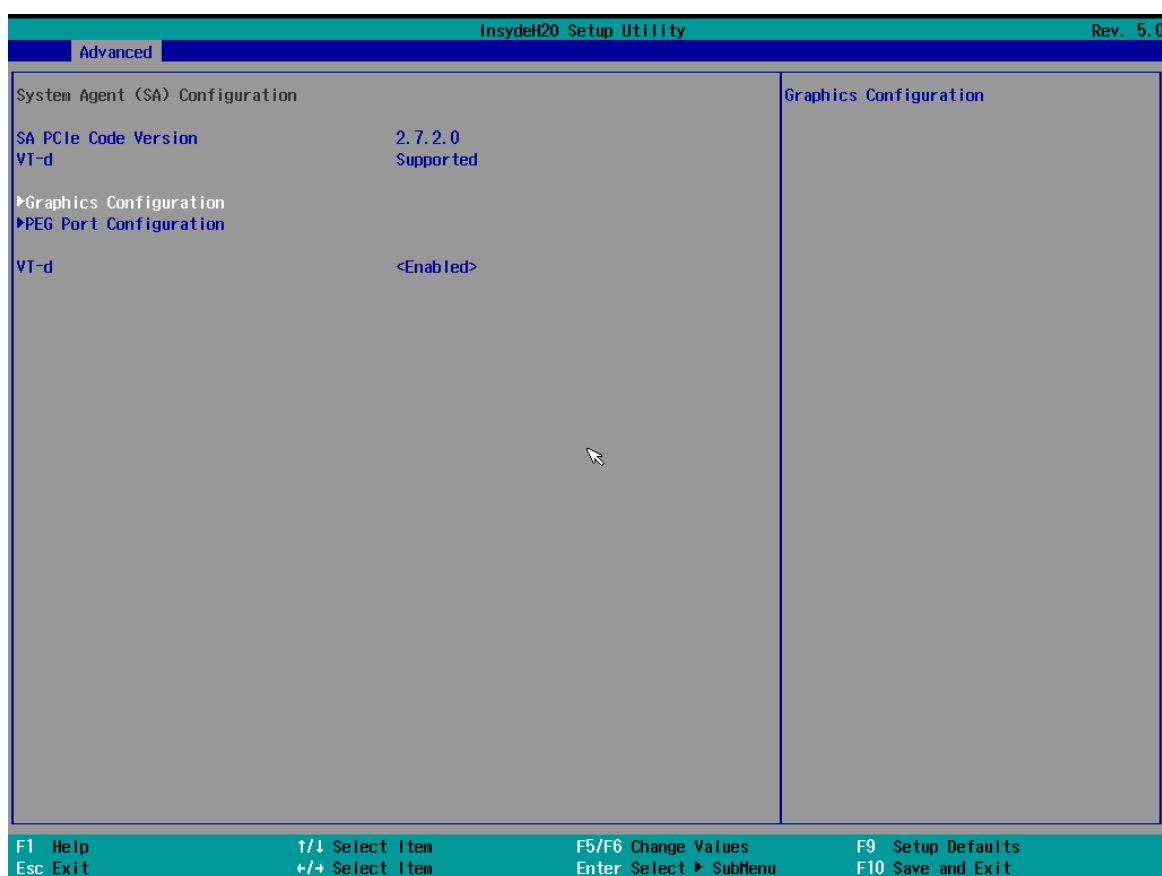

BIOS Setting	Description	Setting Option	Effect
Graphics Configuration	Configure Graphics Configuration parameters	Enter	Opens sub-menu
PEG Port Configuration	Configure PEG Port Configuration parameters	Enter	Opens sub-menu
Vt-d	Intel® Virtualization Technology for Directed I/O	Enabled Disabled	Vt-d capability

5.2.2.3.1 Graphics Configuration

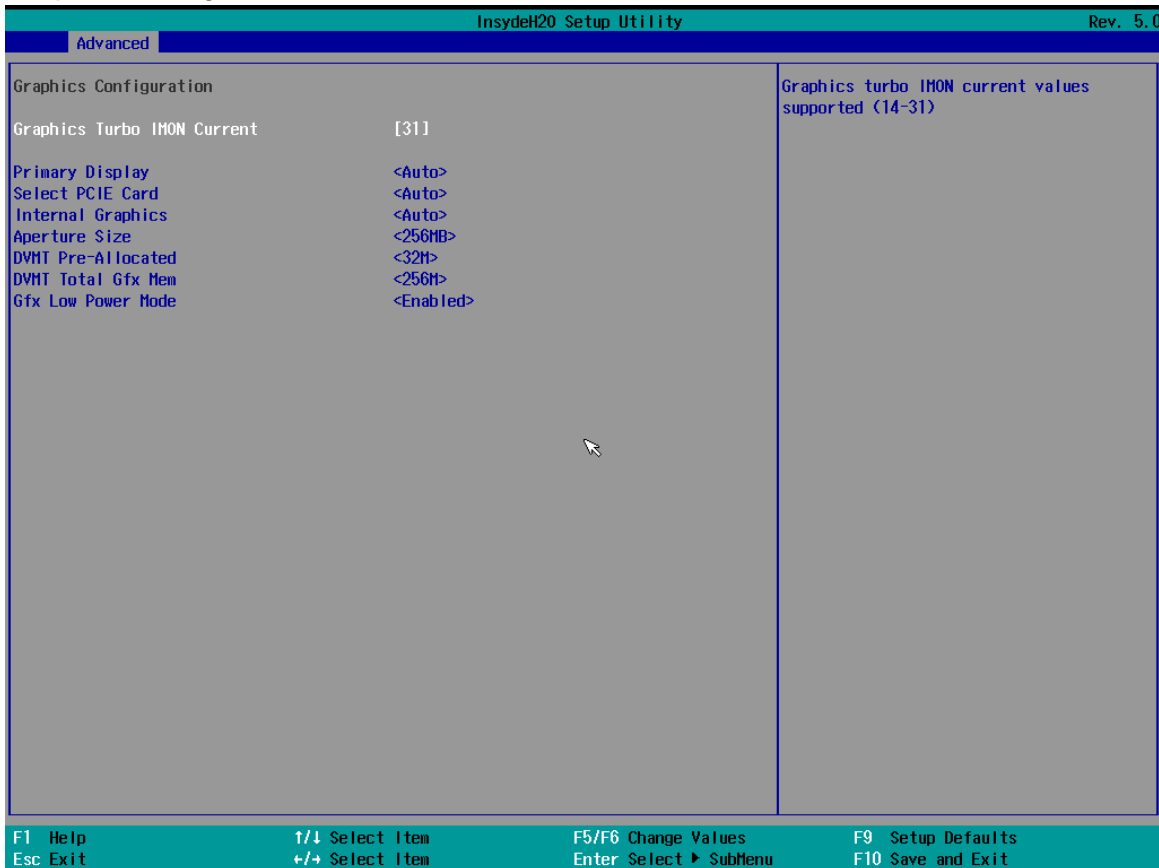

BIOS Setting	Description	Setting Option	Effect
Graphics Turbo IMON Current	Graphics Turbo IMON Current values supported	14-31	Select Graphics Turbo IMON Current values supported
Primary Display	Select Primary Display	Auto IGFX PEG PCI	Select which of IGFX/PEG/ PCI Graphics device should be primary display or select SG for Switchable Gfx
Select PCIE Card	Select the card used on a platform	Auto	Skip GPIO based Power Enable to dGPU
		Elk Greek 4	DGPU Power Enable=ActiveLow
		PEG Eval	DGPU Power Enable=ActiveHigh
Internal Graphics	Internal Graphics settings	Auto Enabled Disabled	Keep IGFX enabled based on the setup options
Aperture Size	Select the aperture size	128MB 256MB 512MB 1024MB 2048 MB	Select the aperture size <i>Note: Above 4MB MMIO BIOS assignment is automatically enabled when selecting 2048MB aperture. To use this feature please disable CSM port</i>
DVMT Pre-Allocated	Select DVMT Pre-Allocated	0M~60M	Select DVMT 5.0 Pre-Allocated (Fixed) Graphic Memory size used by Internal Graphic Device
DVMT Total Gfx Mem	Select DVMT Total Gfx Mem	256M 128M MAX	Select DVMT 5.0 Total Graphic Memory size used by the Internal Graphic Device
Gfx Low Power Mode	Select Gfx Low Power Mode	Enabled/ Disabled	This option is applicable for SFF only

BIOS Setting	Description	Setting Option	Effect
Enable Root Port	Configure Root Port parameters	Enabled Disabled Auto	Enable or disable Root Port
Max Link Speed	Select Max Link Speed	Auto Gen1 Gen2 Gen3	Configure PEG 0:1:0 Max Speed
PEG0 Slot Power Limit Value	PEG0 Slot Power Limit Value	75	PEG0 Slot Power Limit Value
PEG0 Slot Power Limit Scale	Select PEG0 Slot Power Limit Scale	1.0x 0.1x 0.01x 0.001x	Select the scale used for Slot Power Limit Value
Program PCIe ASPM after OpROM	Program PCIe ASPM after OpROM	Disabled	PCIe ASPM will be programmed before OpROM
		Enabled	PCIe ASPM will be programmed after OpROM
Program Static Phase1 Eq	Program Static Phase1 Eq	Disabled Enabled	Program Phase1 Presents/ CTLEp
Always Attemp SW EQ	Always Attemp SW EQ	Disabled Enabled	Always Attemp SW EQ, even it has been done once
Number of Presents to test	Select number of Presents to test	7,3,5,8 0-9 Auto	Choose between 7,3,5,8 and 0-9. Auto = current default (7,3,5,8 for SKL). Do not change the default unless debugging.
Allow PERST # GPIO Usage	Allow PERST # GPIO Usage	Disabled Enabled	Enable/ Disable GPIO-based resets to PEG endpoint(s) during margin search, if needed
SW EQ Enable VOC	Select Jitter, VOC test mode	-Jitter Only Test Mode -Jitter & VOC Test Mode -Auto	Select Jitter & VOC test mode (default) or Jitter only test mode. Auto will current default (Enabled)
Generate BDAT PEG Margin Data	Generate BDAT PEG Margin Data	-Disabled -Generate Port Gitter Data	Enable to generate BDAT PCIe margin tables
PCIe Rx CEM Test Mode	PCIe Rx CEM Test Mode settings	Disabled Enabled	Enable/ Disable PEG Rx CEM Loopback Mode
PCIe Spread Spectrum Clocking	PCIe Spread Spectrum Clocking	Enabled Disabled	Allow disabling Spread Spectrum Clocking for compliance testing
Gen3 Root Port Present value for each Lane	Gen3 Root Port Present value for each Lane	Lane 0-Lane 15	Value for Lane 0- Lane 15
Gen3 Root Port Endpoint value for each Lane	Gen3 Root Port Endpoint value for each Lane	Lane 0-Lane 15	Value for Lane 0- Lane 15
Gen3 Endpoint Hint value for each Lane	Gen3 Endpoint Hint value for each Lane	Lane 0-Lane 15	Value for Lane 0- Lane 15
Gen3 RxCTLE Control	Gen3 RxCTLE Control	Bundle0-Bundle7	Gen3 RxCTLE settings for Bundle0 (Lane0, Lane1)
		RxCTLE Override	When enabled, it overrides PEG's RxCTLE adaptive behavior

5.2.2.3.3 VT-d

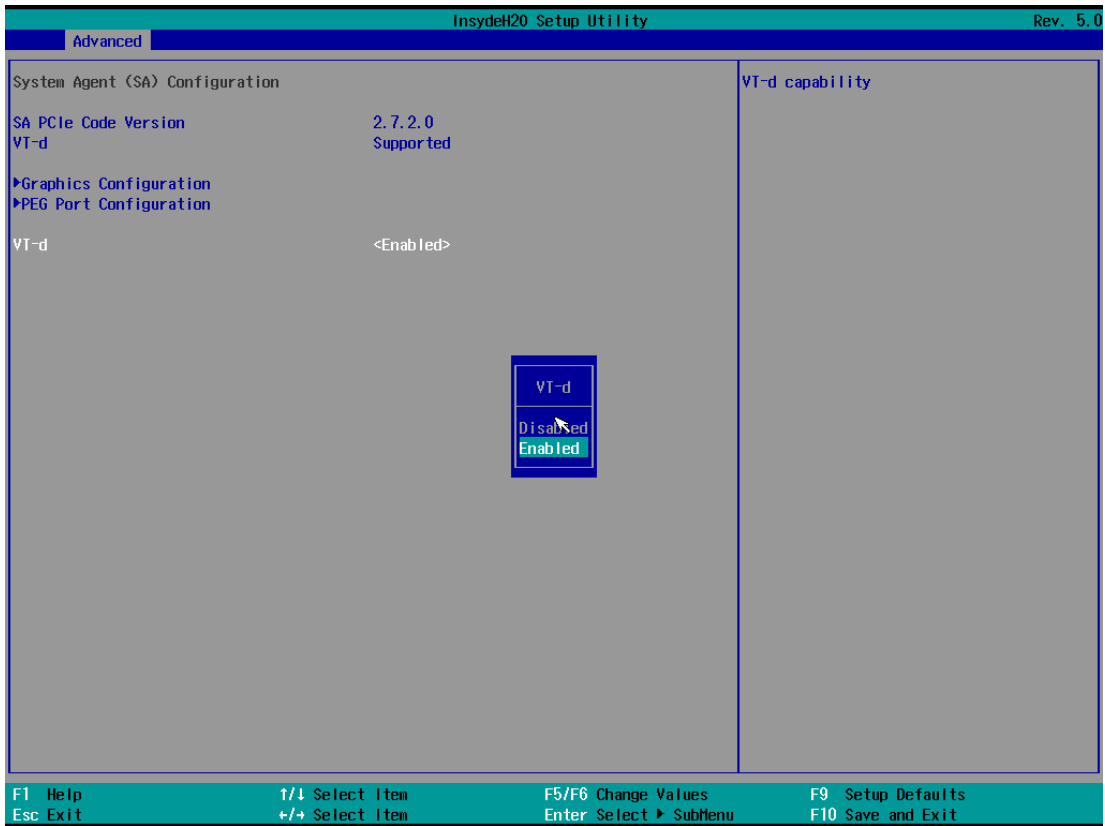

BIOS Setting	Description	Setting Option	Effect
Vt-d	Intel® Virtualization Technology for Directed I/O	Enabled Disabled	Vt-d capability

5.2.2.4 PCH-IO Configuration

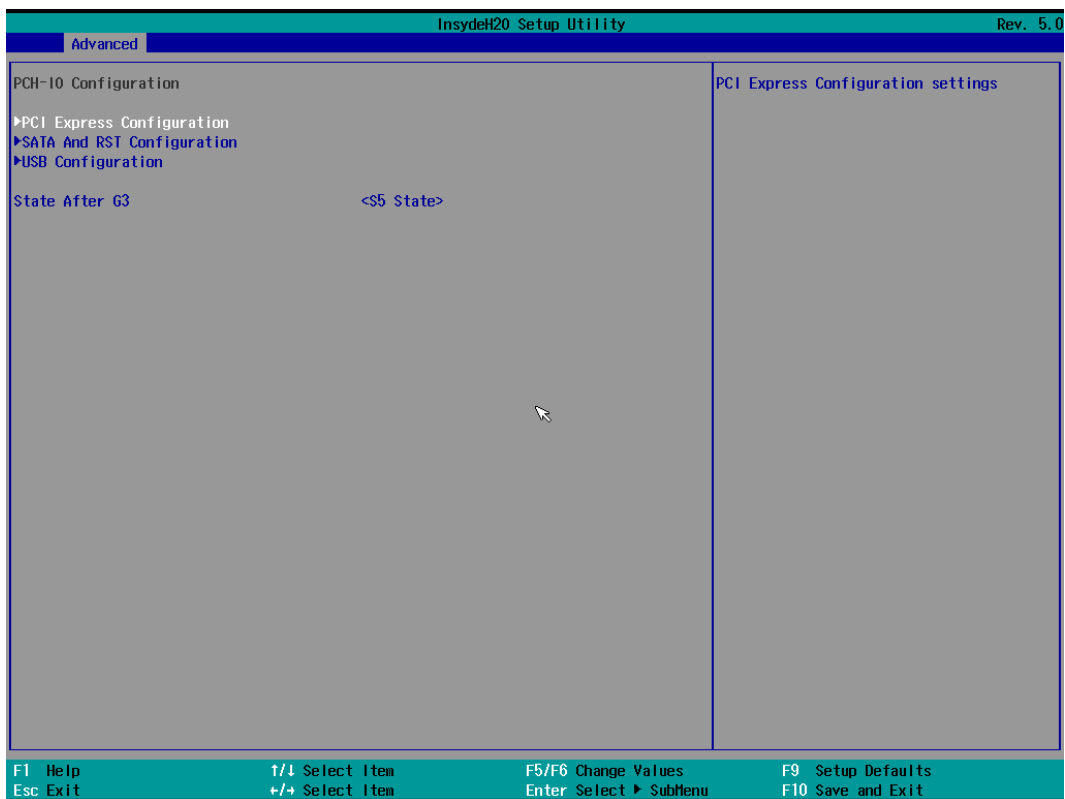

BIOS Setting	Description	Setting Option	Effect
PCI Express Configuration	Configure PCI Express settings	Enter	Opens sub-menu
SATA And RST Configuratuion	Configure SATA And RST settings	Enter	Opens sub-menu
USB Configuration	Configure USB settings	Enter	Opens sub-menu
State After G3			

5.2.2.4.1 PCI Express Configuration

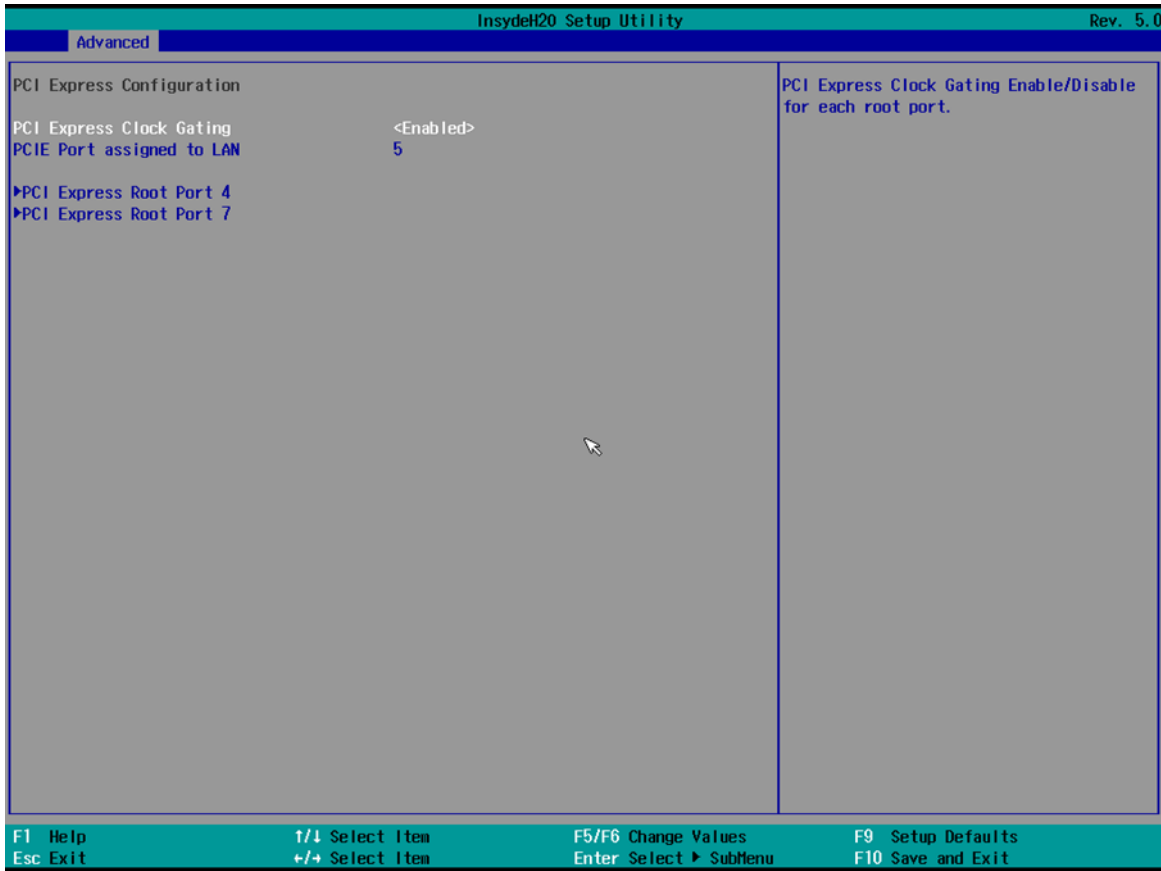

BIOS Setting	Description	Setting Option	Effect
PCI Express Clock Gating	PCI Express Clock Gating settings	Enabled Disabled	PCI Express Clock Gating Enable/ Disable for each root port
PCI Port assigned to LAN	PCI Port assigned to LAN settings	Value	Choose value
PCI Express Root Port 4	Control the PCI Express Root Port 4	Enter	Opens sub-menu
PCI Express Root Port 7	Control the PCI Express Root Port 7	Enter	Opens sub-menu

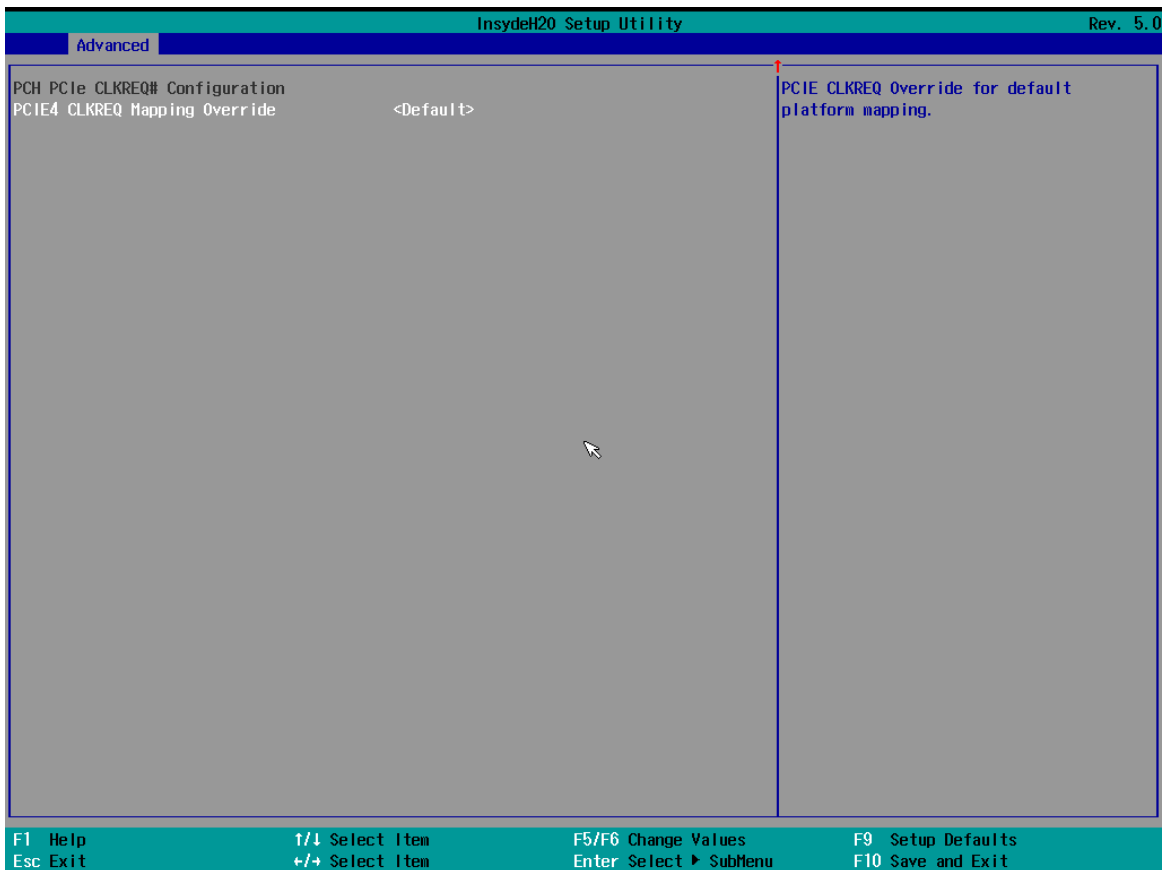
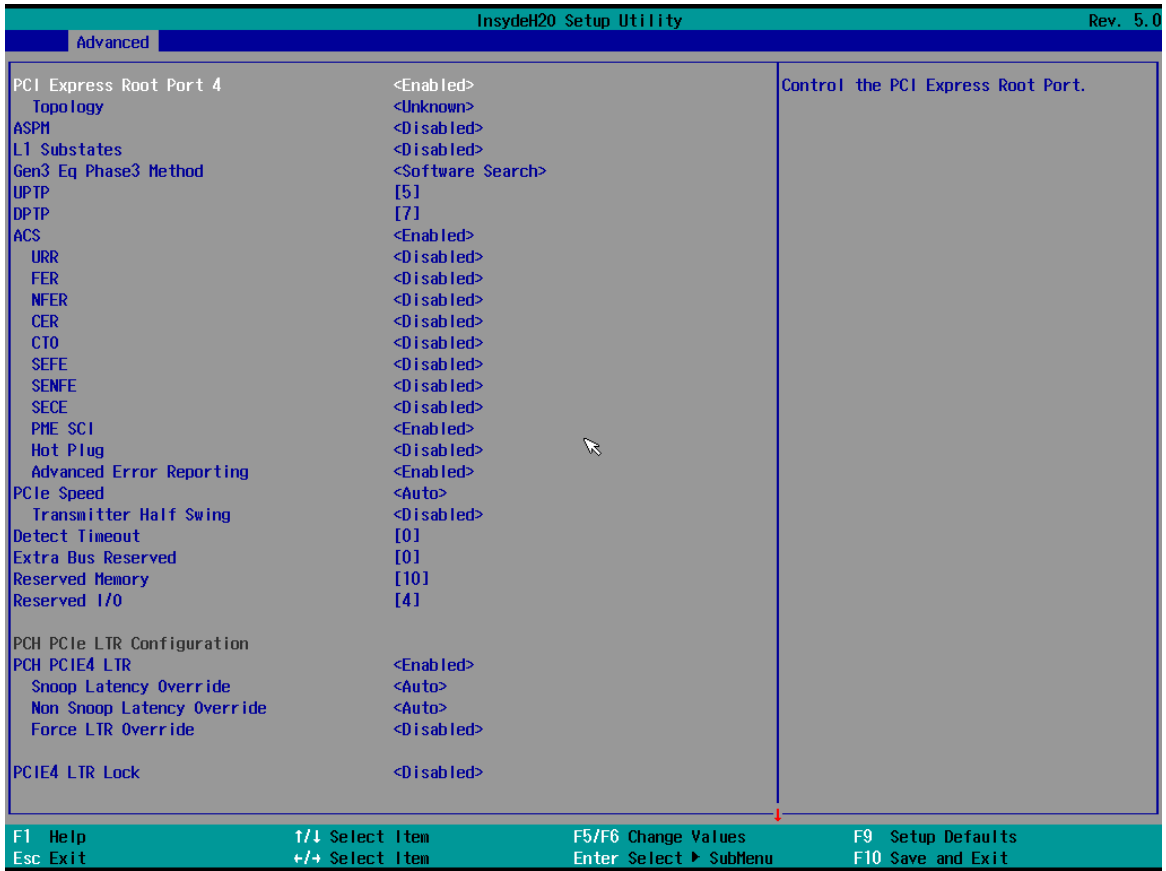

BIOS Setting	Description	Setting Option	Effect
PCI Express Root Port 4	Control the PCI Express Root Port 4	Enter	Opens sub-menu
Topology	Topology settings	Unknown x1 x4 SATA Express M2	Identify the SATA Topology if it is Default or ISATA or Flex or DirectConnect or M2
ASPM	ASPM settings	Auto L0sL1 L1 L0s Disabled	Automatically enable ASPM based on reported capabilities and known issues
L1 Substates	PCIE Express L1 Substates settings	Disabled L1.1 L1.2 L1.1 & L1.2	PCIE Express L1 Substates settings
Gen3 Eq Phase3 Method	Gen3 Eq Phase3 Method settings	Hardware Static Coefic Software Search	PCIe Gen3 Equalization Phase 3 Method
ACS	Access Control Services Extended Capability settings	Disabled Enabled	Enable/ Disable Access Control Services Extended Capability
PCIe Speed	Configure PCIe Speed	Auto Gen1 Gen2 Gen3	Configure PCIe Speed
PCH PCIE4 LTR	PCH PCI Latency Reporting Enable/ Disable	Disabled Enabled	PCH PCI Latency Reporting Enable/ Disable
PCIE4 LTR Lock	PCIE4 LTR Lock settings	Disabled Enabled	PCIE4 LTR Configuration Lock
PCIE4 CLKREQ Mapping Override	PCIE4 CLKREQ Mapping Override	Default No CLKREQ Custom Number	PCIE4 CLKREQ Mapping Override for default platforma mapping

5.2.2.4.2 SATA and RST Configuration

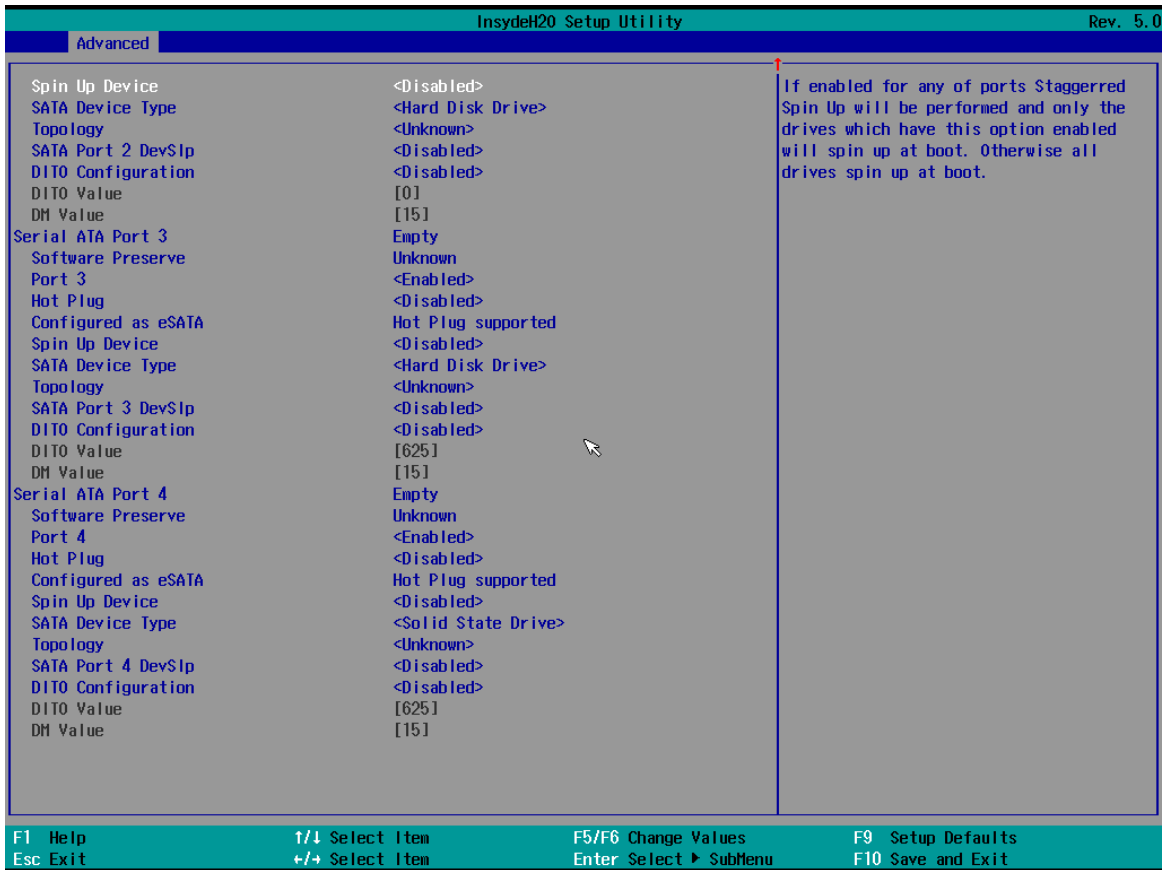

5.2.2.4.3 USB Configuration

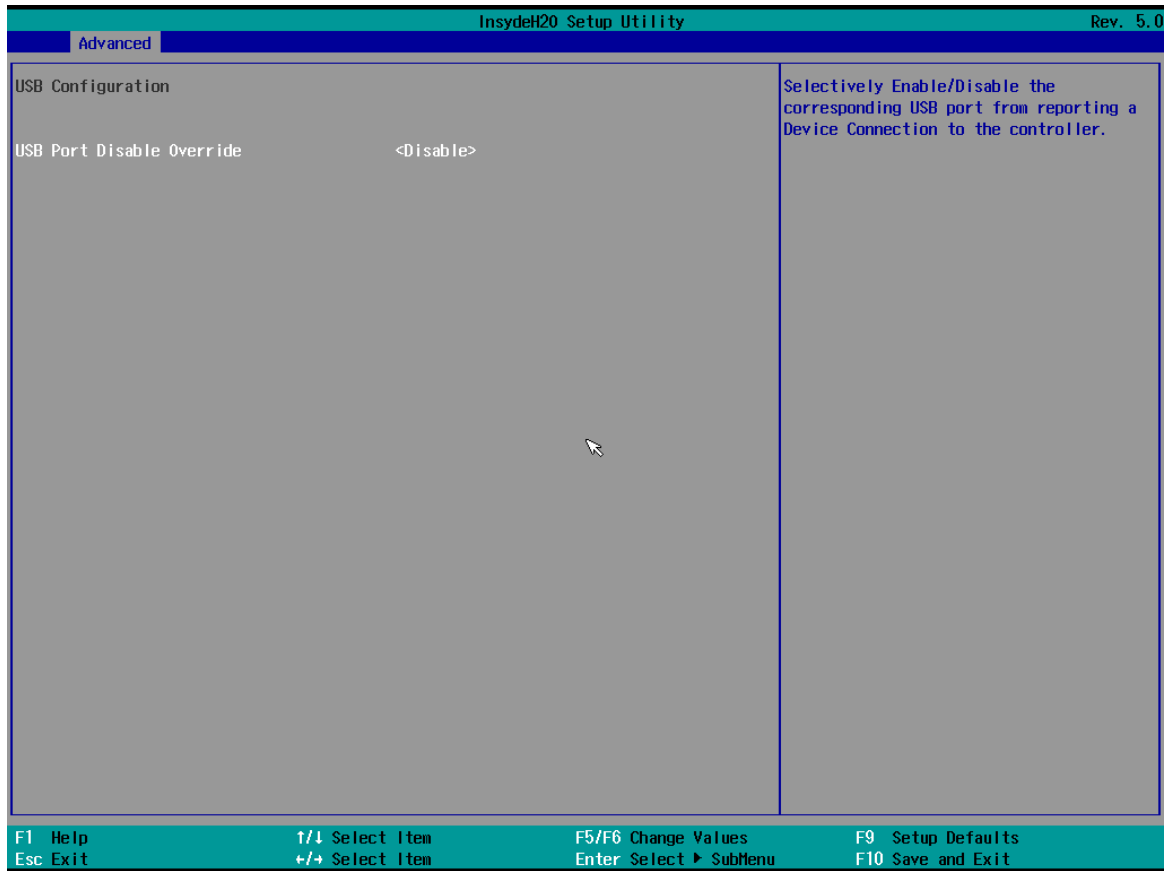

BIOS Setting	Description	Setting Option	Effect
USB Port Disable Override	USB Port Disable Override configuration	Disable Select Per-Pin	Selectively Enable/Disable the corresponding USB port from reporting a Device Connection to the controller

5.2.2.4.4 State After G3

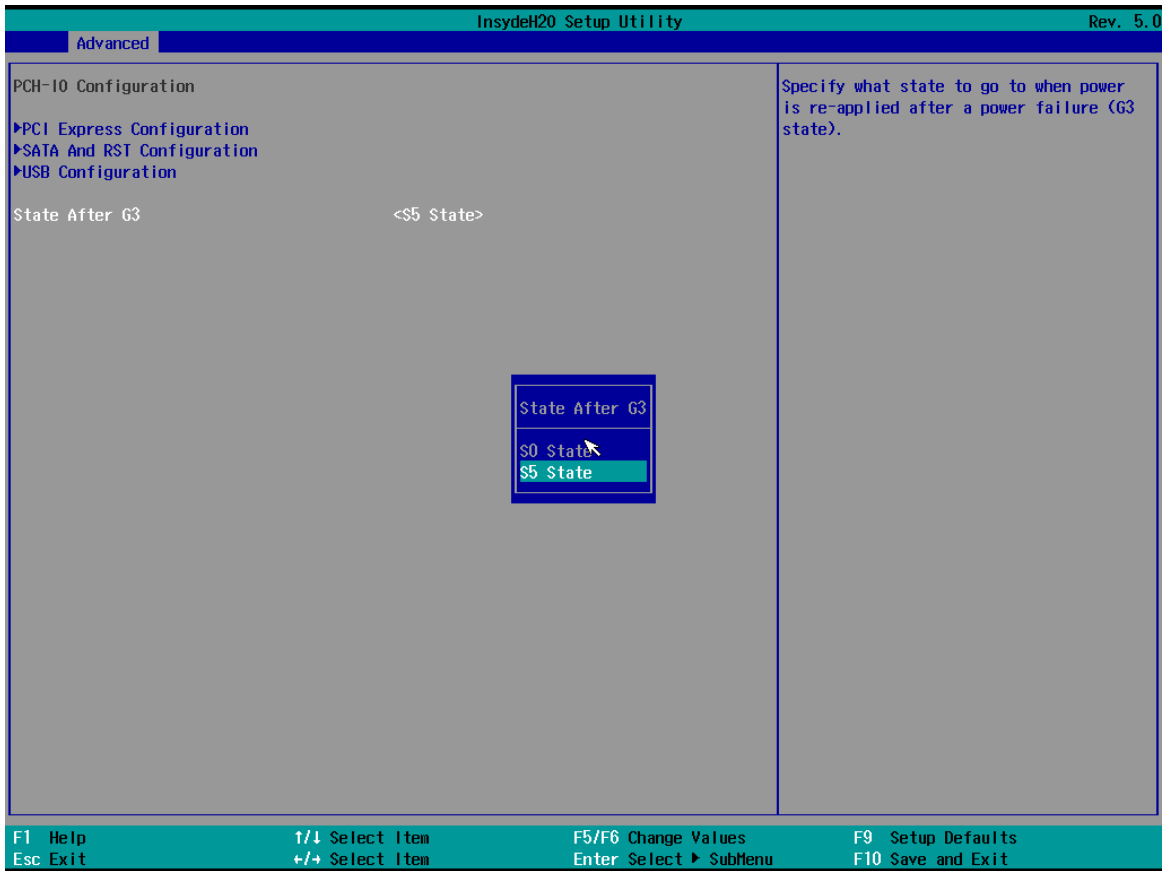

BIOS Setting	Description	Setting Option	Effect
State After G3	State After G3 configuration	S0 State S5 State	Specify what state to go to when power is re-applied after a power failure (G3 state)

5.2.2.5 PCH-FW Configuration

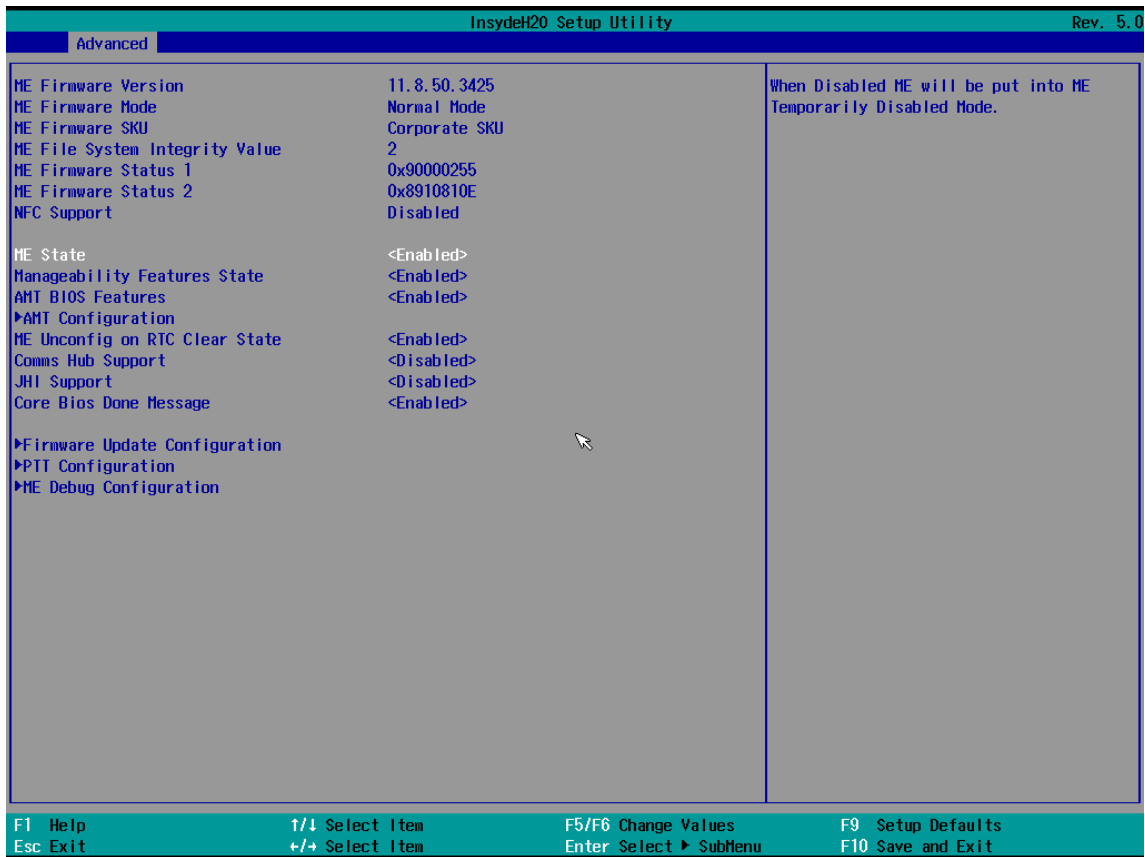

BIOS Setting	Description	Setting Option	Effect
ME State	ME State configuration	Disabled Enabled	When Disabled ME will be put into ME Temporarily Disabled Mode
Manageability Features State	Manageability Features State configuration	Disabled Enabled	Enable/ Disable Intel Manageability Features <i>Note: this option disabled/ enables Manageability Features support in FW. To disable support platform must be in an unprovisioned state first.</i>
AMT BIOS Features	AMT BIOS Features	Disabled Enabled	Enable/ Disable Intel Active Management Technology BIOS Extension. <i>Note: iAMT H/W Is always enabled. This option just controls the BIOS Extension execution.</i>
AMT Configuration	AMT Configuration	Enter	Opens sub-menu
ME Unconfig on RTC Clear State	ME Unconfig on RTC Clear State	Disabled Enabled	Disabling this option will cause ME not to unconfigure on RST clear
Comms Hub Support	Comms Hub Support	Disabled Enabled	Enable/Disable support for Comms Hub
JHI Support	JHI Support	Disabled Enabled	Enable/Disable Intel DAL Host Interface Service (JHI)
Core BIOS Done Message	Core BIOS Done Message	Disabled Enabled	Enable /Disable Core BIOS Done message sent to ME
Firmware Update Configuration	Firmware Update Configuration	Enter	Opens sub-menu
PTT Configuration		Enter	Opens sub-menu
ME Debug Configuration			

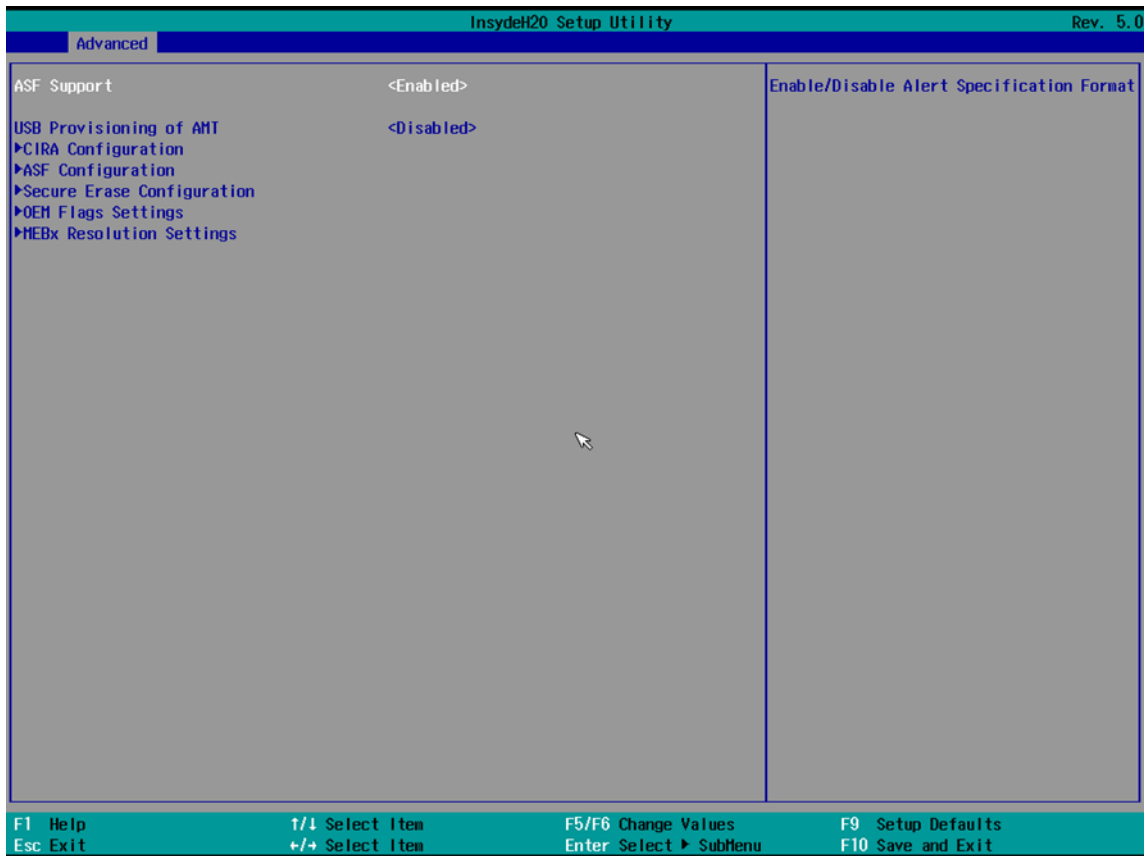

BIOS Setting	Description	Setting Option	Effect
USB Provisioning of AMT	USB Provisioning of AMT	Disabled Enabled	Enable/ Disable of AMT USB provisioning
Activate Remote Assistance Process	Trigger CIRA Boot	Value	<i>Note: Network Access must be activated first from MEBx Setup</i>
PET Progress	PET Progress configuration	Disabled Enabled	Enable/ Disable PET Events Progress to receive PET Events.
Watchdog	Watchdog Timer configuration	Disabled Enabled	Enable/ Disable Watchdog Timer
Secure Erase Mode	Change Secure Erase Mode behavior	Simulated	Performs SE flow without erasing SSD
		Real	Erase SSD
Force Secure Erase	Force Secure Erase	Disabled Enabled	Force Secure Erase on next boot

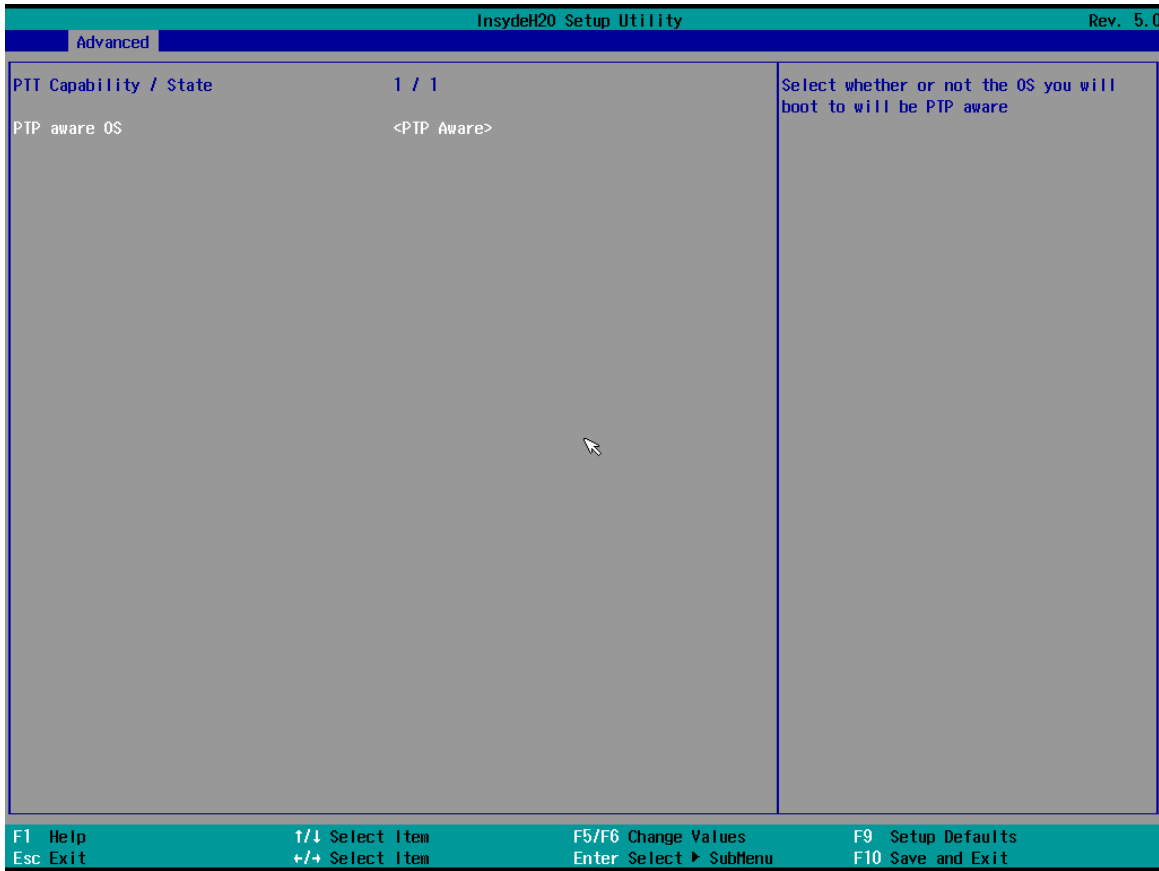

BIOS Setting	Description	Setting Option	Effect
PTT Capability/ State	PTT Capability/ State configuration	1/1	Select whether or not the OS you will boot to will be PTP aware
PTP aware OS	PTP aware OS	PTP Aware Not PTP Aware	Select whether or not the OS you will boot to will be PTP aware

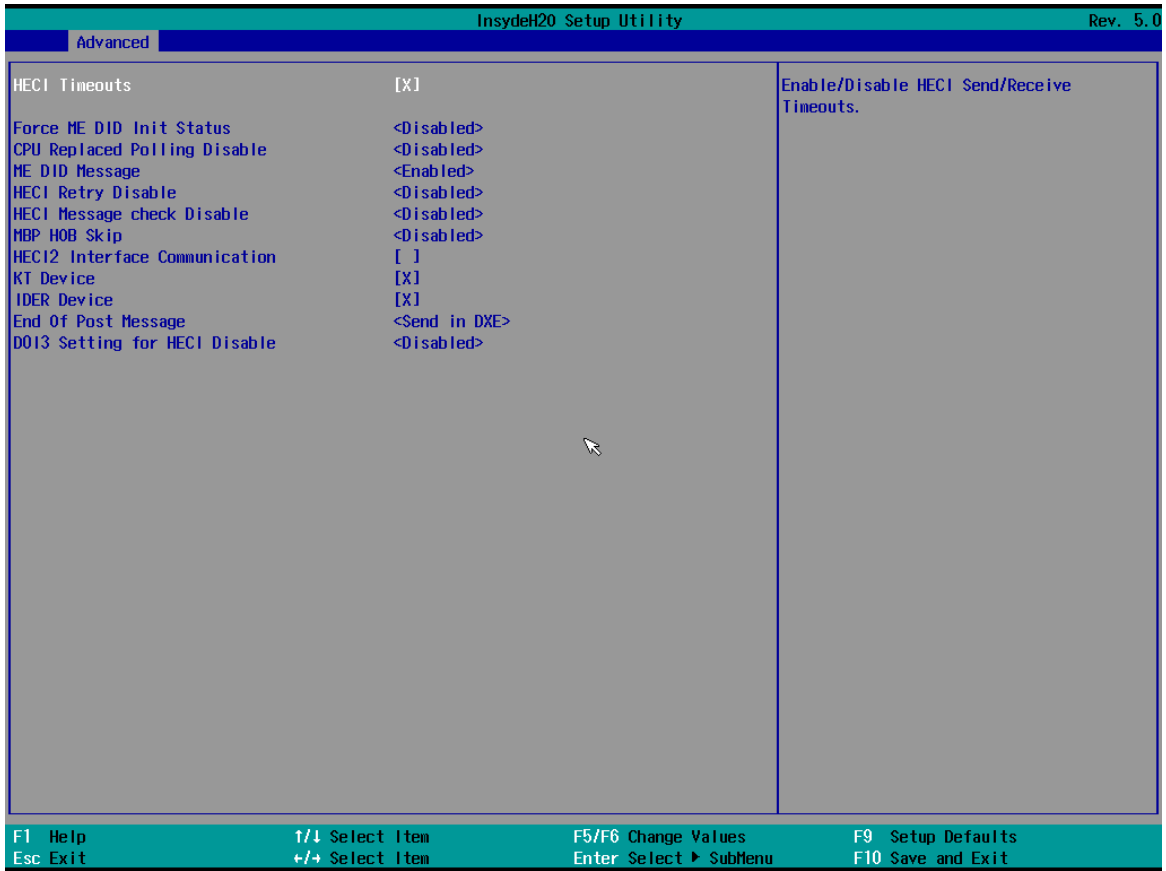

5.2.2.6 SIO F81866A

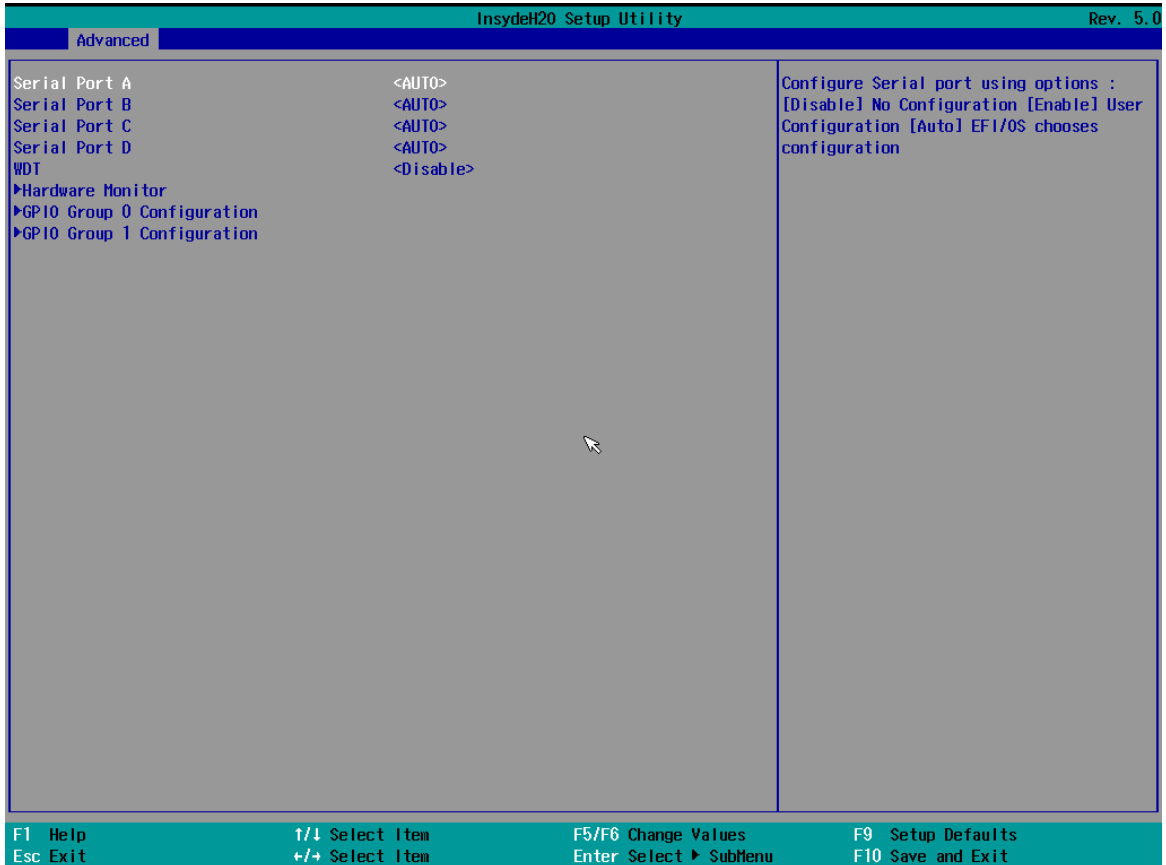

BIOS Setting	Description	Setting Option	Effect
Serial Port A ~ Serial Port D	Configure Serial port settings	Disable	No configuration
		Enable	User configuration
		Auto	EFI/OS chooses configuration
WDT	Watchdog Timer configuration	Disable Enable	Enable or disable Watchdog Timer
Hardware Monitor	Hardware Monitor	Enter	Opens sub-section
GPIO Group 0 Configuration	GPIO Group 0 Configuration	Enter	Opens sub-section
GPIO Group 1 Configuration	GPIO Group 1 Configuration	Enter	Opens sub-section

5.2.2.6.1 Hardware Monitor



BIOS Setting	Description	Setting Option	Effect
FAN1 Mode	FAN1 Mode configuration	Manual Linear Stage	Select FAN1 Mode configuration

5.2.2.6.2 GPIO Configuration



BIOS Setting	Description	Setting Option	Effect
Internal Resistance	Internal Resistance configuration	Push Pull Open Drain	User can pull internal resistance push-pull / open-drain
Input/ Output Mode	GPIO pin configuration	Input Output	Set GPIO pin is input or output

5.2.2.7 Console Redirection

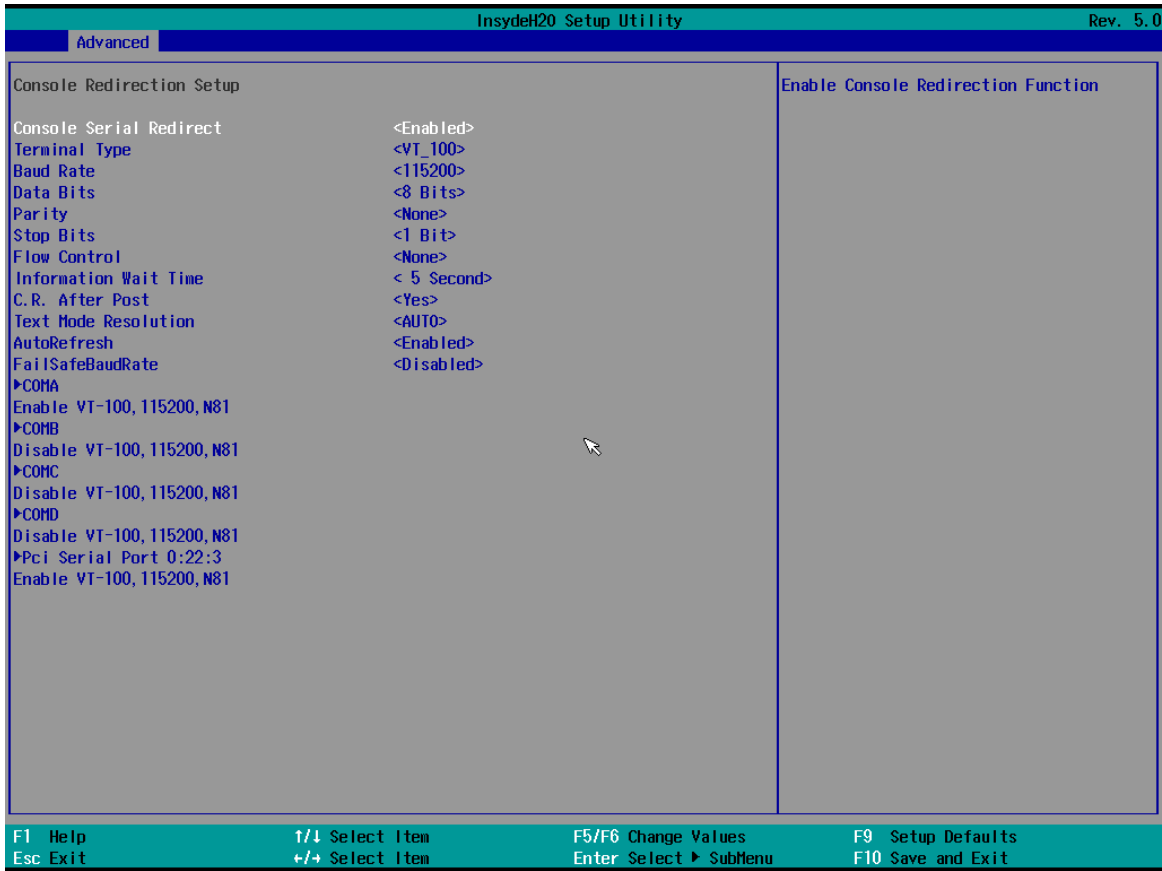

BIOS Setting	Description	Setting Option	Effect
Console Serial Redirect	Console Redirection Function settings	Enabled Disabled	Enable Console Redirection Function
Terminal Type	Console Redirection Terminal Type settings	VT_100 VT_100+ VT_UTF8 PC_ANSI	Set Console Redirection Terminal Type
Baud Rate	Console Redirection Baud Rate settings	115200 57600 38400 19200 9600 4800 2400 1200	Set Console Redirection Baud Rate
Data Bits	Data Bits settings	7bits/ 8bits	Set Data Bits
Parity	Console Redirection Parity bit settings	None Even Odd	Set Console Redirection Parity bit
Stop Bits	Console Redirection Stop Bits settings	1 Bit 2 Bits	Set Console Redirection Stop Bits
Flow Control	Console Redirection Stop Flow Control Type settings	None RTS/ CTS XON/ XOFF	Set Console Redirection Stop Flow Control Type
Information Wait Time	Console Redirection port information display time settings	0 sec~30 sec	Set Console Redirection port information display time
C.R. After Post	Console Redirection continue work after POST time	Yes No	Console Redirection continue work after POST time
Text Mode Resolution	Console Redirection Text Mode Resolution	Auto	Follows VGA text mode
		Force 80x25	Don't care VGA, force text mode be 80x25
		Force 80x24 (DEL FIRST RAW)	Don't care VGA, force text mode be 80x24 (DEL FIRST RAW)
		Force 80x24(DEL LAST RAW)	Don't care VGA, force text mode be 80x24 (DEL LAST RAW)
Auto Refresh	Auto Refresh settings	Disabled Enabled	When feature enabled, screen will be auto refresh once after detect remote terminal was connected
Fail Safe Baud Rate	Fail Safe Baud Rate settings	Disabled Enabled	This feature will auto detect remote terminal baud rate and connect C.R. serial device with detected baud rate

5.2.3 Security

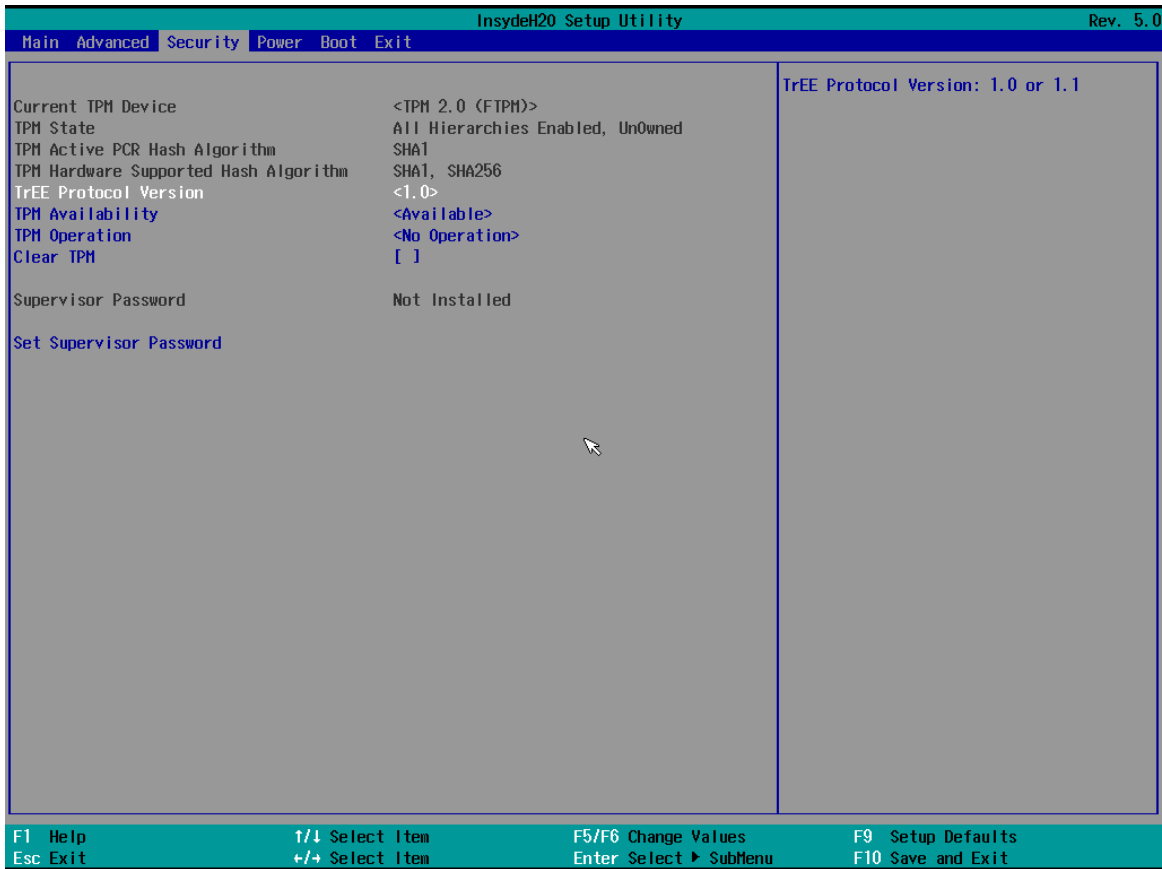

BIOS Setting	Description	Setting Option	Effect
TrEE Protocol Version	Choose TrEE Protocol Version	1.0 1.1	TrEE Protocol Version: 1.0 or 1.1
TPM Availability	TPM Availability configuration	Available Hidden	When hidden don't exposes TPM to 0
TPM Operation	TPM Operation configuration	[]	Select one of the supported operation to change TPM2state
Clear TPM	Clear TPM configuration	[]	Select to Clear TPM
Set Supervisor Password	Set Supervisor Password	Enter New password	Install or Change the password and the length of password must be greater than one character

5.2.4 Power

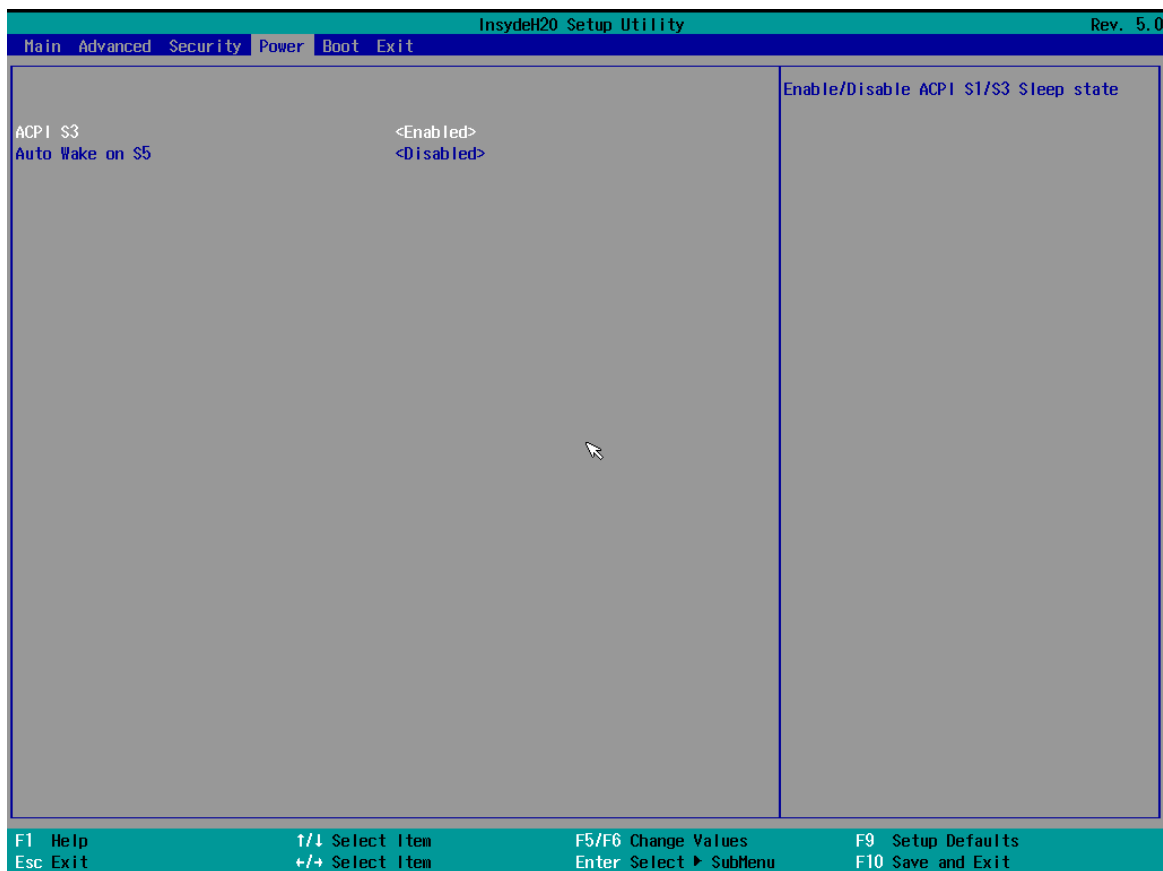

BIOS Setting	Description	Setting Option	Effect
ACPI S3	ACPI S3 configuration	Disabled Enabled	Enable/ Disable ACPI S1/S3 Sleep state
Auto Wake on S5	Auto Wake on S5 configuration	Disabled By Every Day By Every Month	Auto Wake on S5, by Day or Month or fixed time of every day

5.2.5 Boot

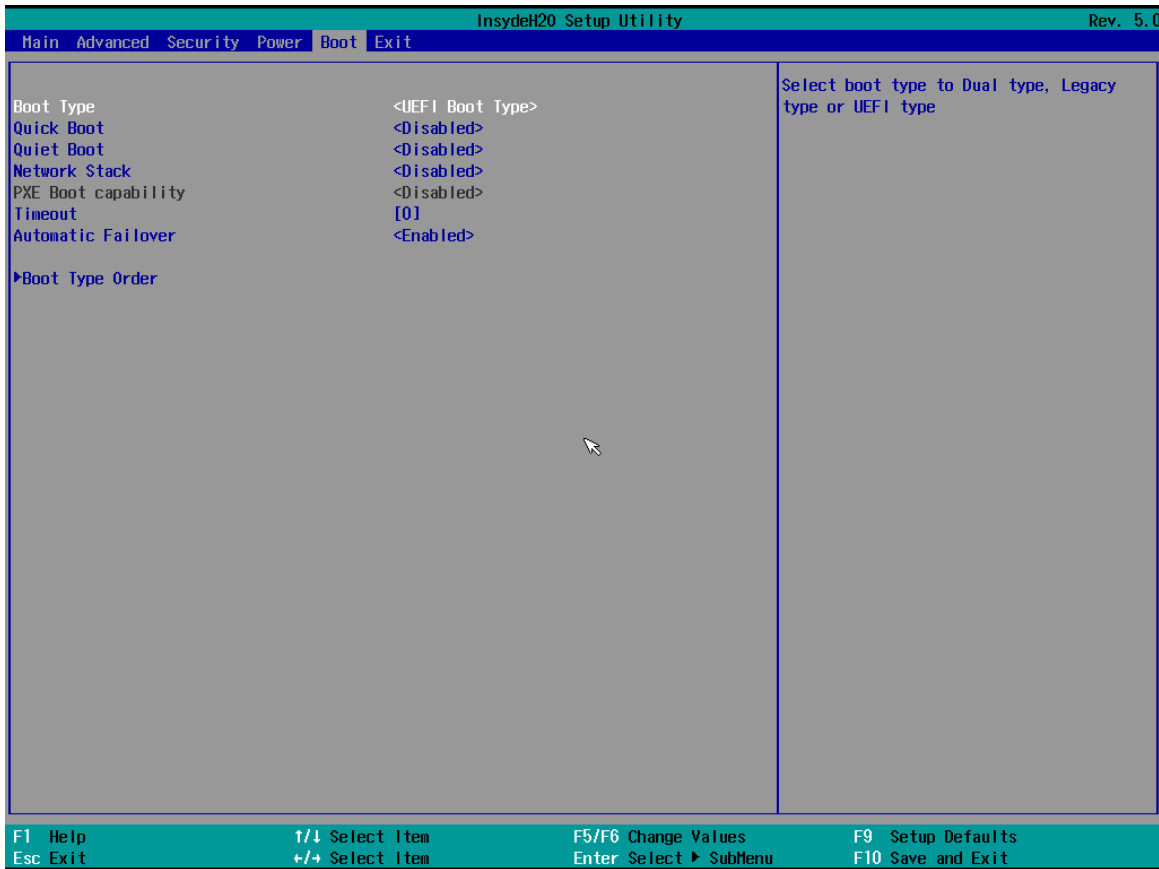

BIOS Setting	Description	Setting Option	Effect
Boot Type	Boot Type configuration	UEFI Boot Type	Select boot type to Dual type, Legacy type or UEFI type
Quick Boot	Quick Boot configuration	Enabled Disabled	Allows InsydeH20 to skip certain tests while booting. This will decrease the time needed to boot the system
Quiet Boot	Quiet Boot configuration	Enabled Disabled	Disable or enable booting in text Mode.
Network Stack	Network Stack configuration	Disabled Enabled	Network Stack Support: Windows 8 Bitlocker Unlock UEFI IPv4/ IPv6 PXE Legacy PXE OPROM
Timeout	Timeout	[Value]	Timeout settings
Automatic Failover		Enable	If boot to default device fail, it will directly try to boot next device
		Disable	If boot to default device fail, it will pop warning message then go to firmware UI
Boot Type Order	Boot Type Order	Enter	Opens sub-menu

5.2.6 Exit

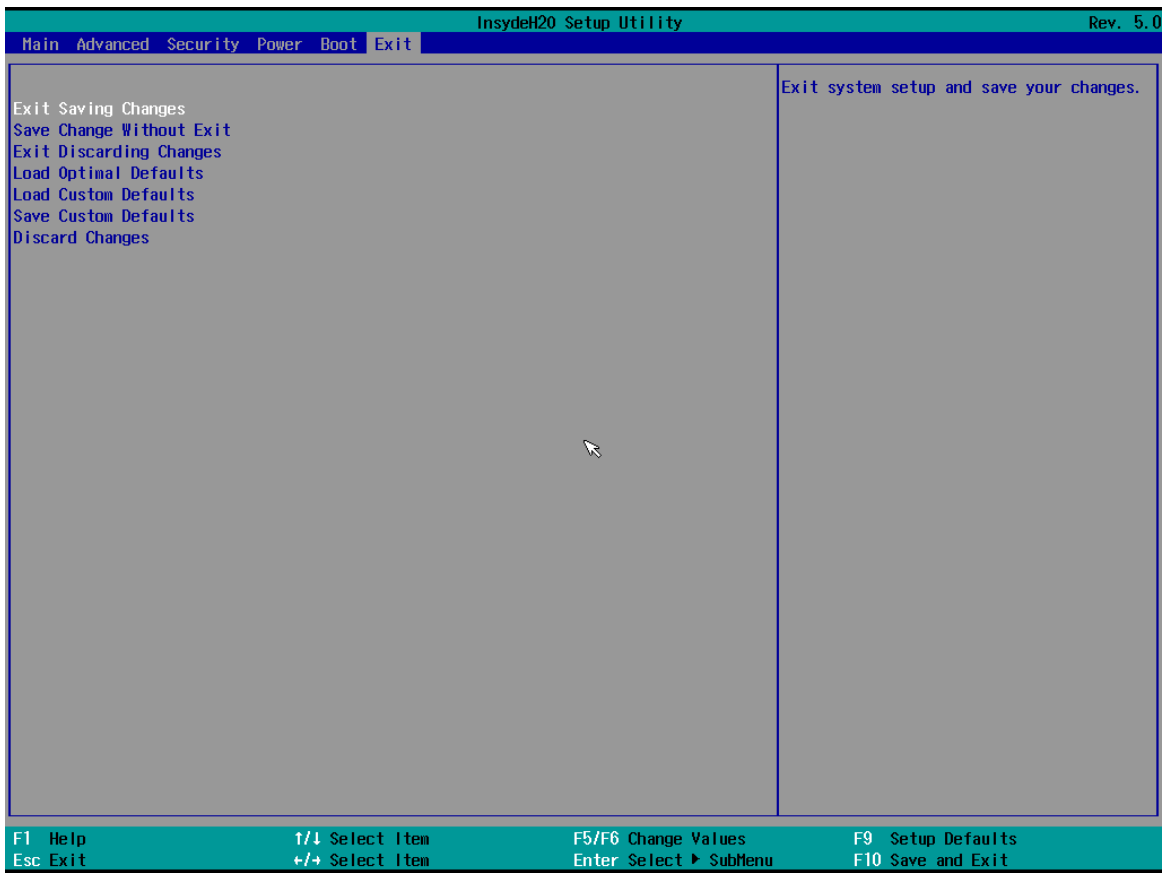

5.3 Using Recovery Wizard to Restore Computer



Note: Before starting the recovery process, make sure to backup all user data. The data will be lost after the recovery process.



Important: Before starting the recovery process, remove any expansion card.

To enable quick one-key recovery procedure:

1. Connect the computer to the power source. Make sure the computer stays plugged in to power source during the recovery process.
2. Turn on the computer, and when the boot screen shows up, press **F6** to initiate the Recovery Wizard.
3. The following screen shows the Recovery Wizard. Click **Recovery** button to continue.

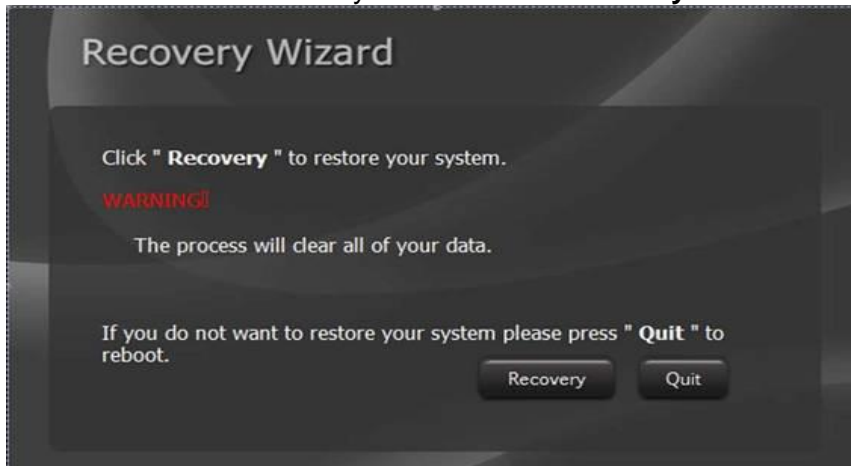

4. A warning message about data loss will show up. Make sure the data is backed up before recovery, and click **Yes** to continue.



5. Wait the recovery process to complete. During the recovery process, a command prompt will show up to indicate the percent of recovery process complete. The system will restart automatically after recovery completed

Chapter 6: Driver Installation

This chapter provides guideline to driver installations.

6.1 Chipset Driver

Follow instructions below to install Chipset driver.

1. Open the Driver CD (included in the package) and select **Chipset** driver.

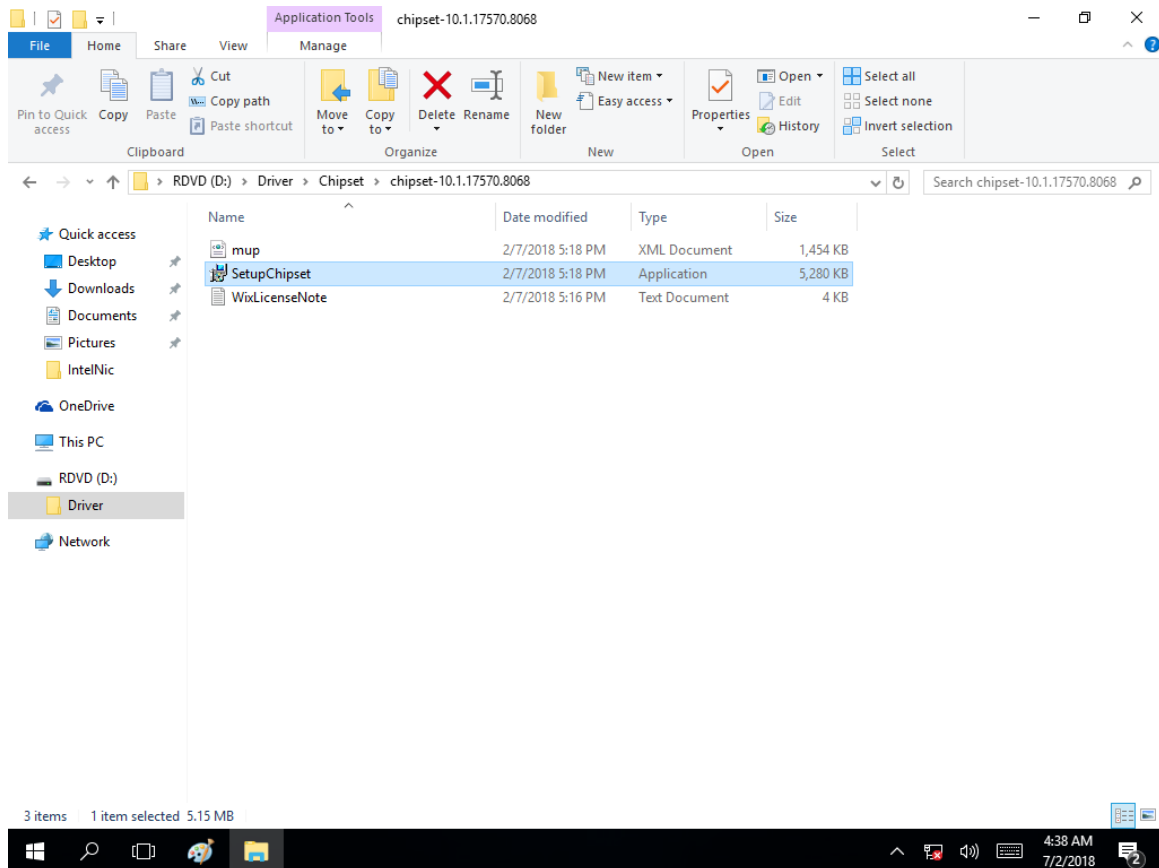

2. Installation window will pop up, select **Next**.

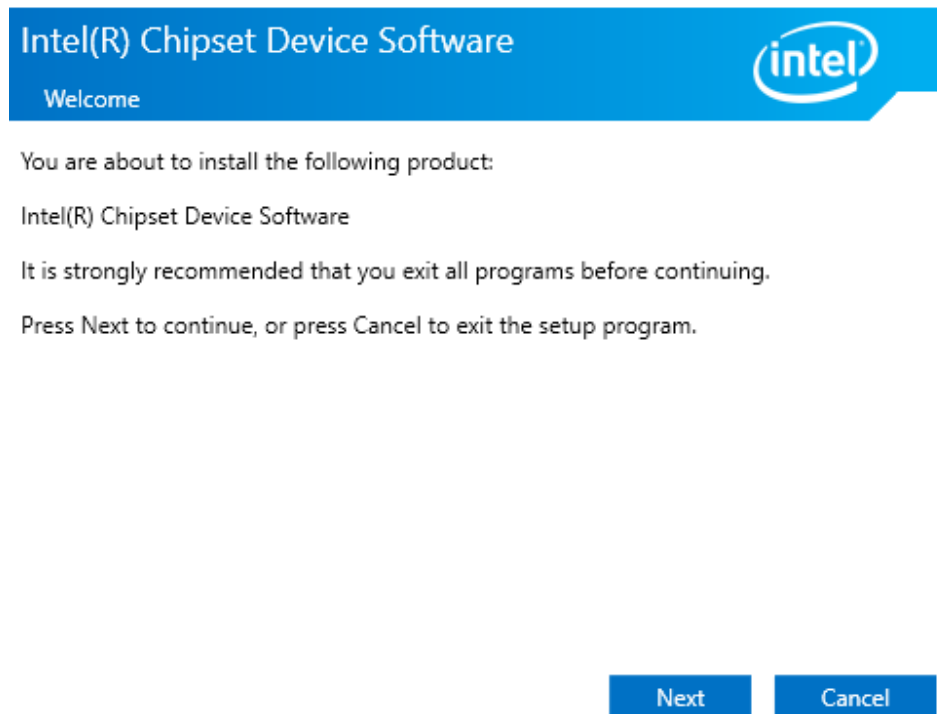

3. Select **Accept** to agree with the terms of license agreement.

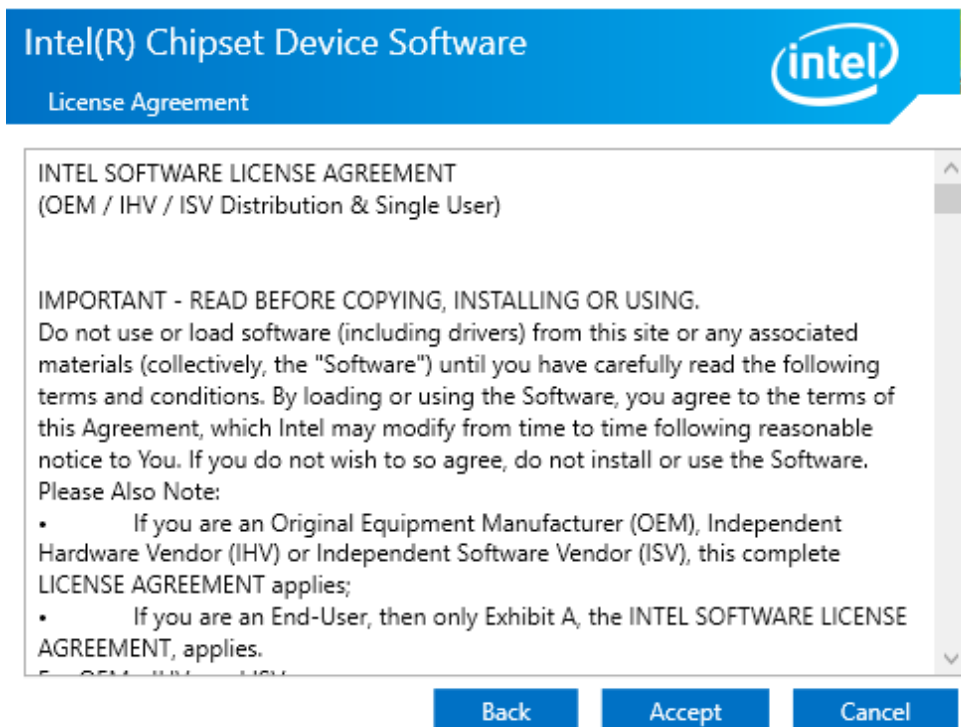

4. Check the ReadMe file information, select **Install** to continue.

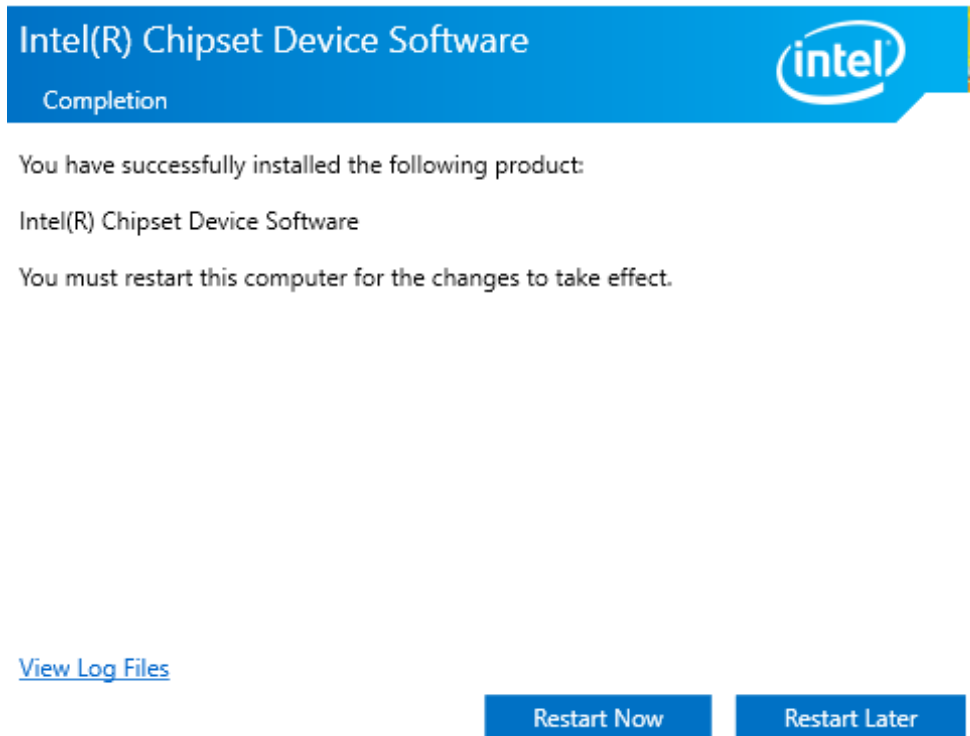

5. Wait for the driver to be installed. When installation completed, select **Restart Now** to restart your computer.



6.2 Graphic Driver

Follow instructions below to install Graphic driver.

1. Open the Driver CD (included in the package) and select **Graphic** driver.

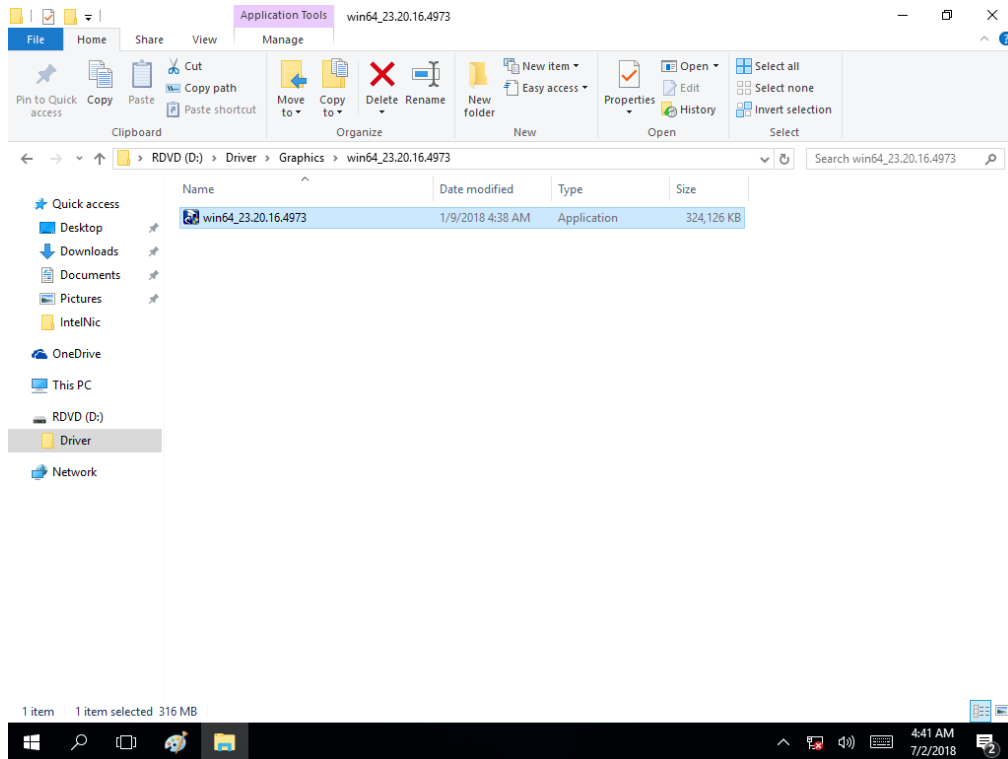

2. Installation window will pop up, select **Next**.

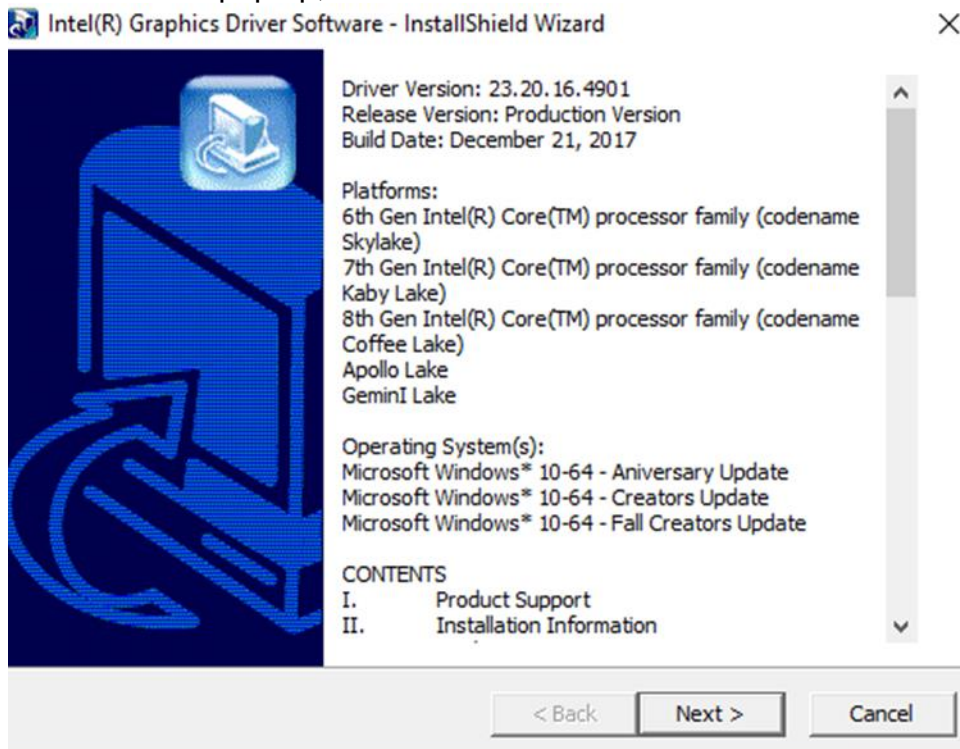

3. Select Accept to agree with the terms of license agreement.

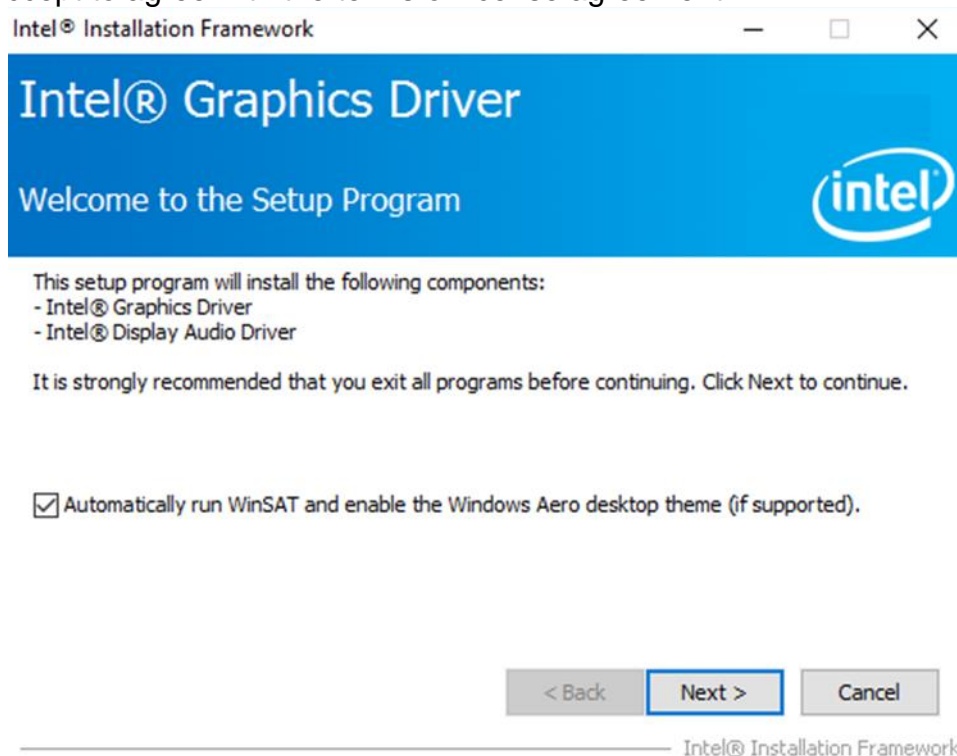
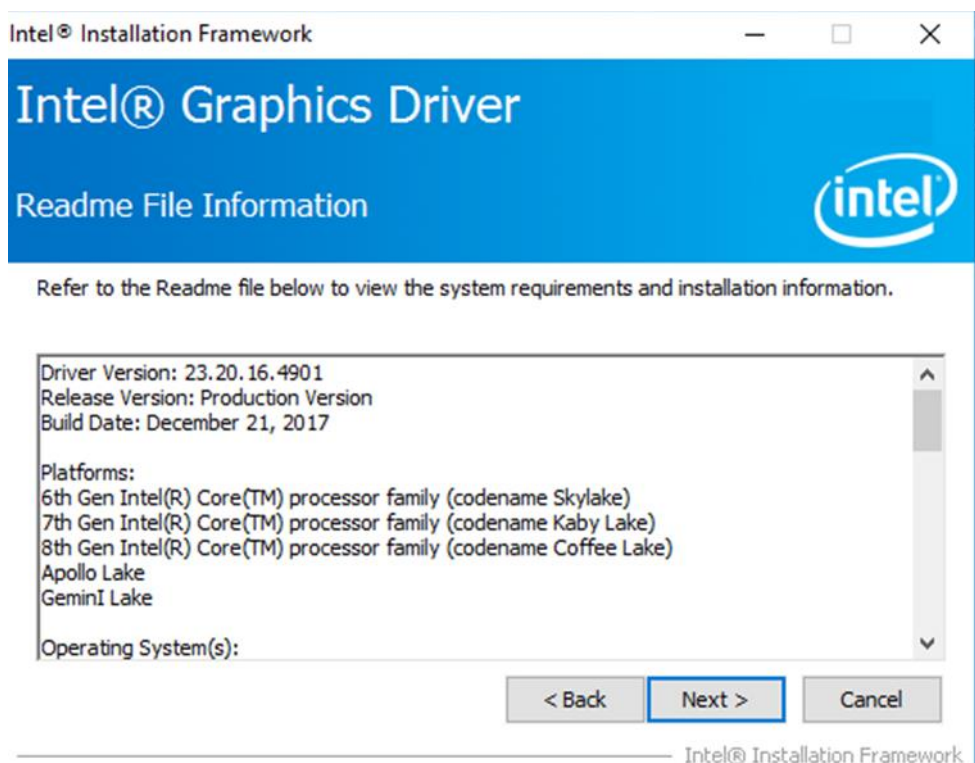
4. Check the ReadMe file information, select **Next** to continue.

5. Wait for the driver to be installed.

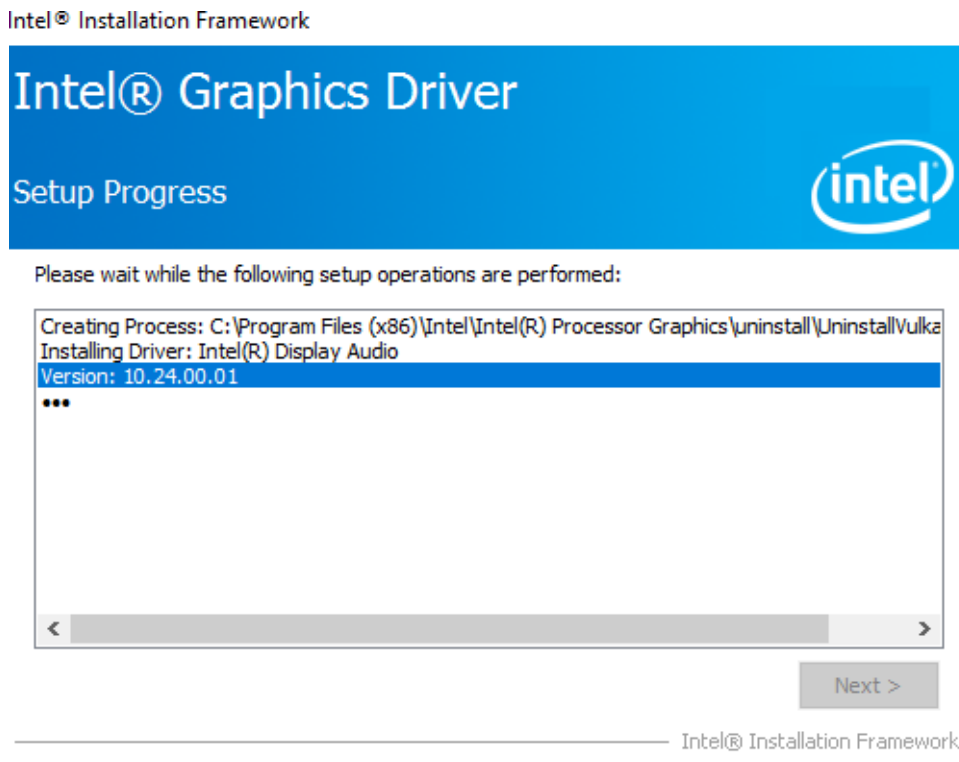

6. Select **Next** to continue.

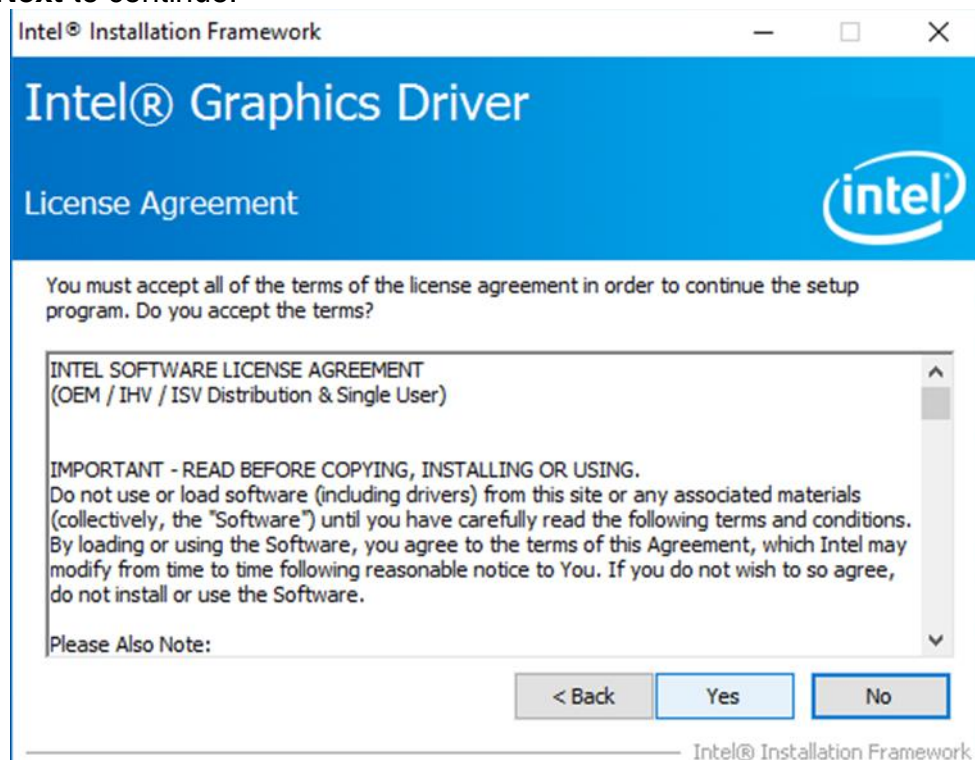

7. After installation is completed, select **“Yes, I want to restart this computer now”**, and click **Finish**.

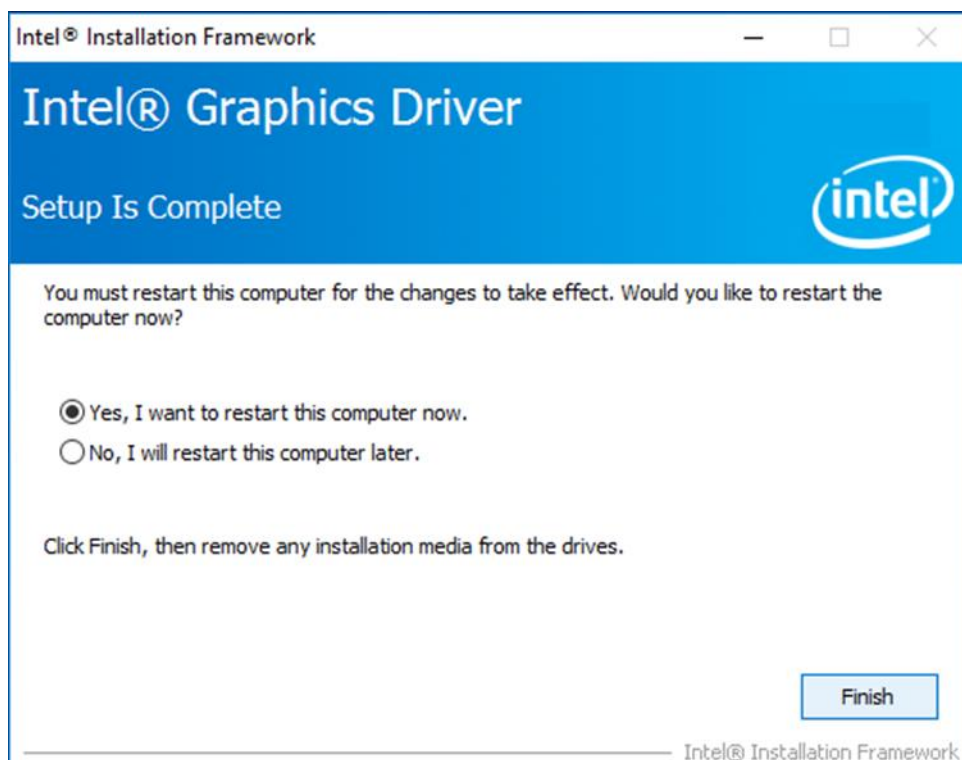

6.3 Management Engine (ME)

Follow instructions below to install Management Engine (ME) .

1. Open the Driver CD (included in the package) and select **ME** driver.

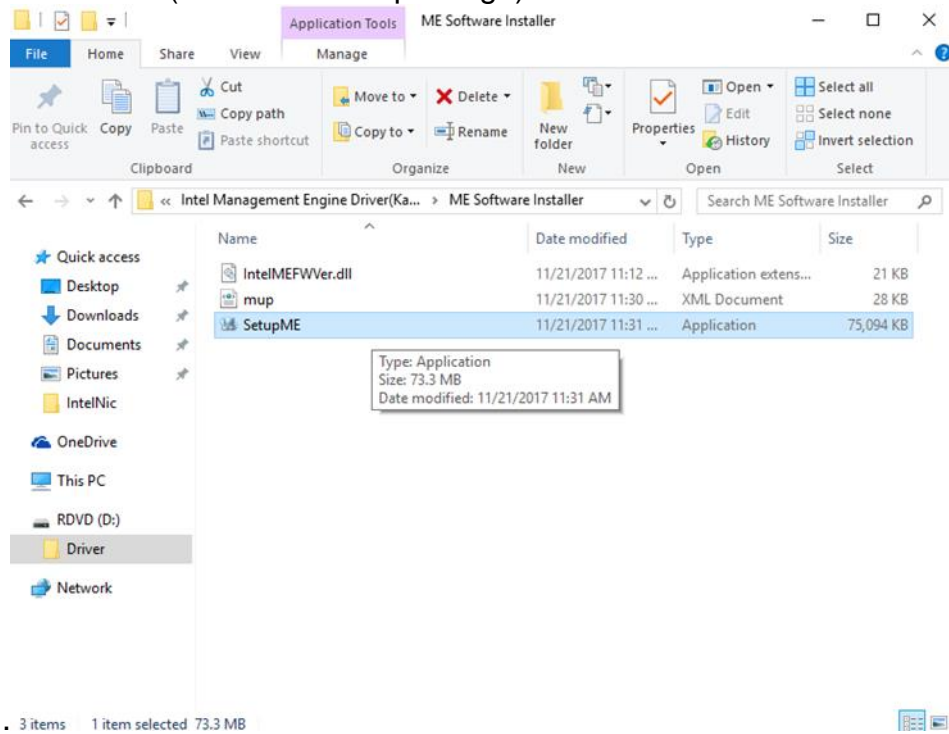

2. Select **Next** to start the installation.

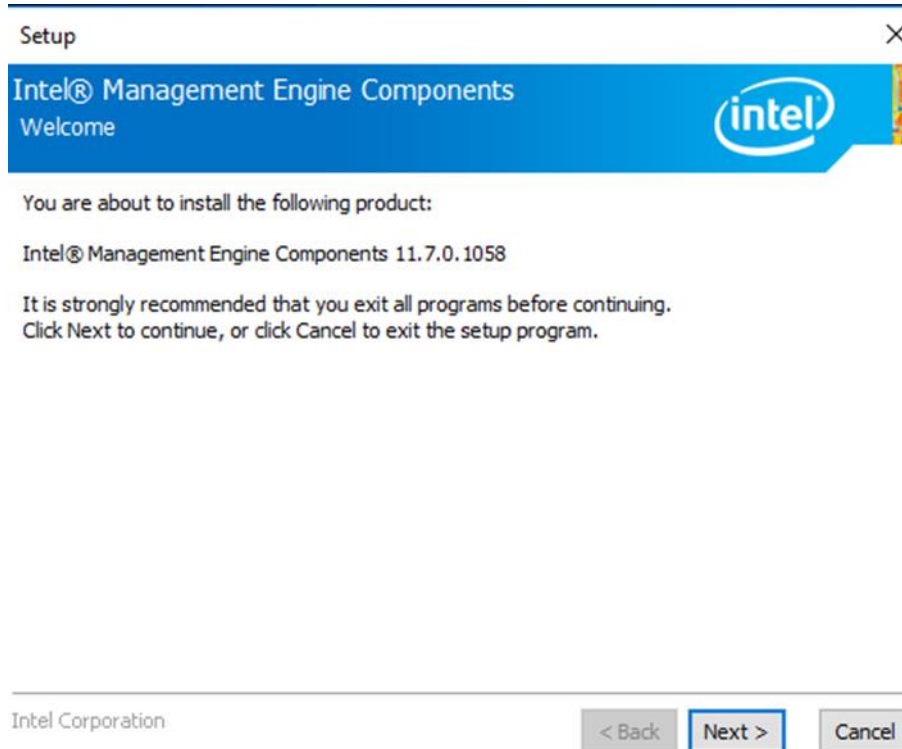

3. Select **Next** to agree with the terms of license agreement.

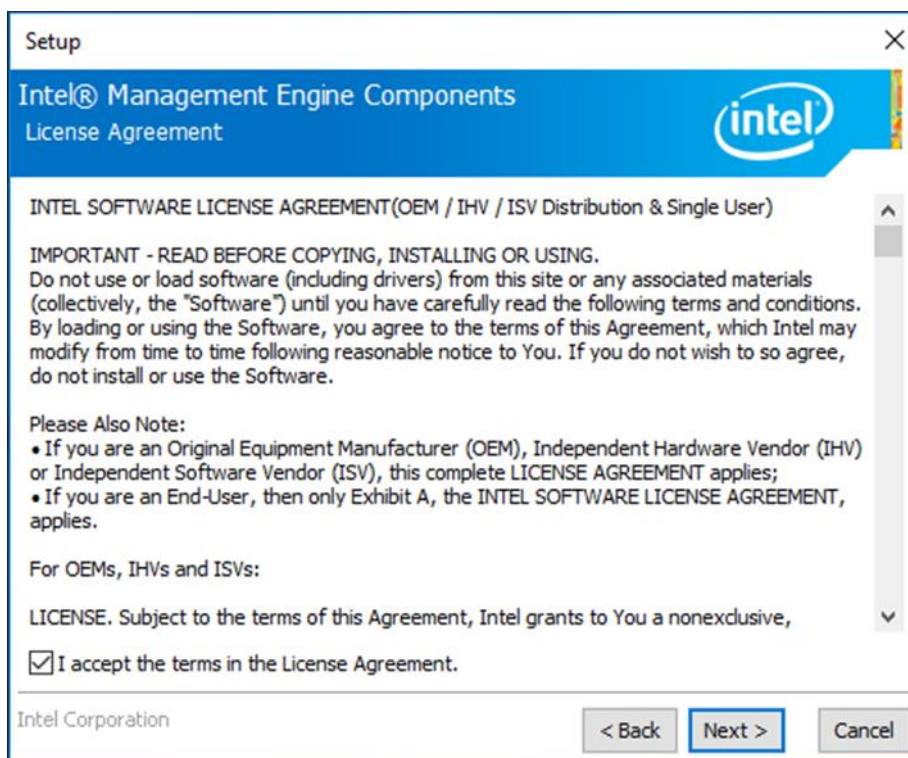

4. Wait for the driver to be installed.

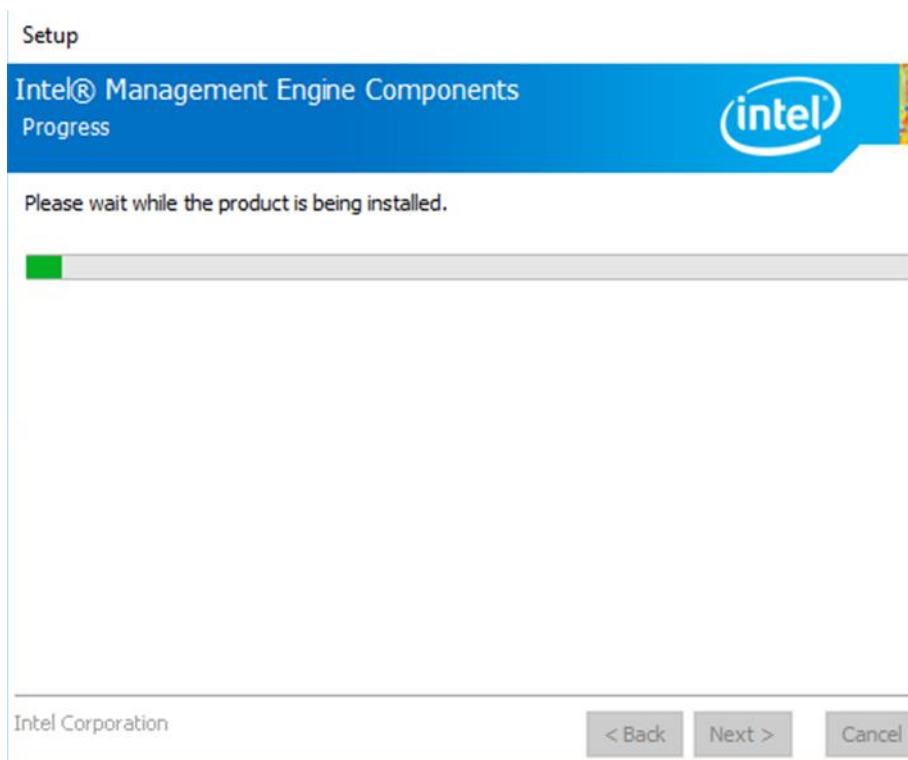

5. When installation completed, select **Finish** complete installation.

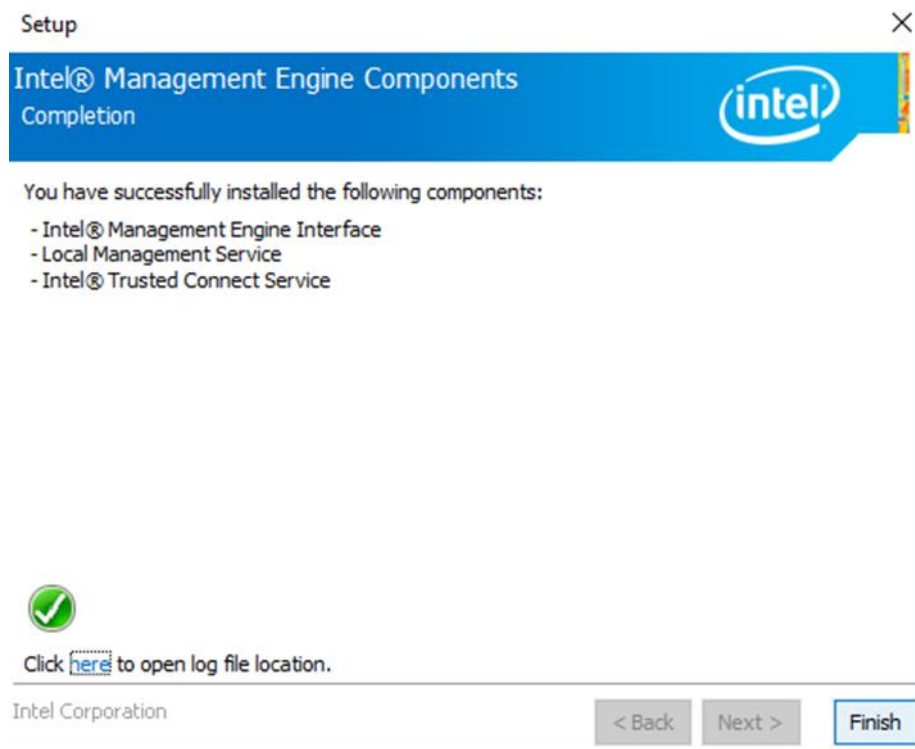

6.4 Audio Driver

Follow instructions below to install Audio driver.

1. Open the Driver CD (included in the package) and select **Audio** driver.

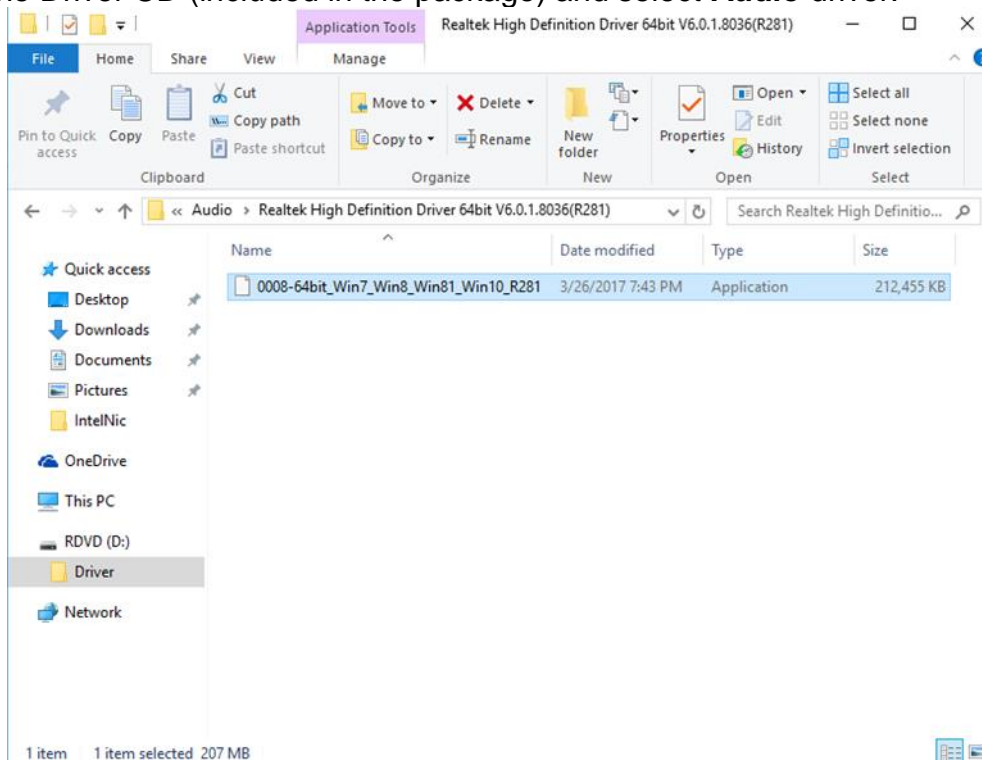

2. Select **Next** to continue.

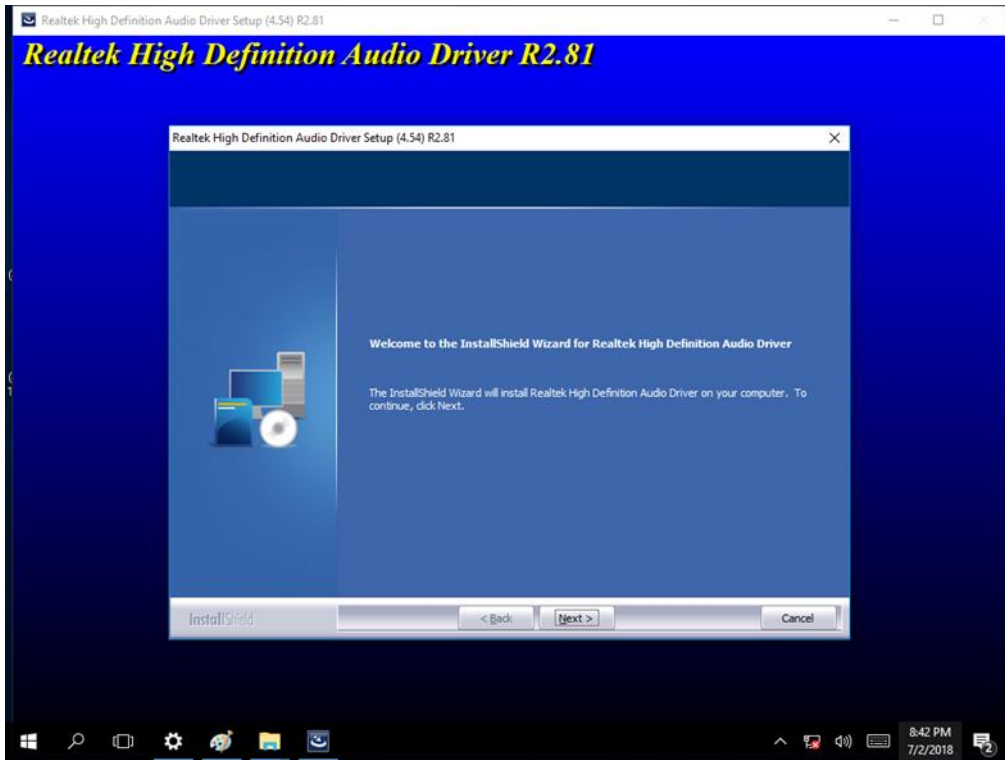

3. When installation completed, select **Finish** complete installation.

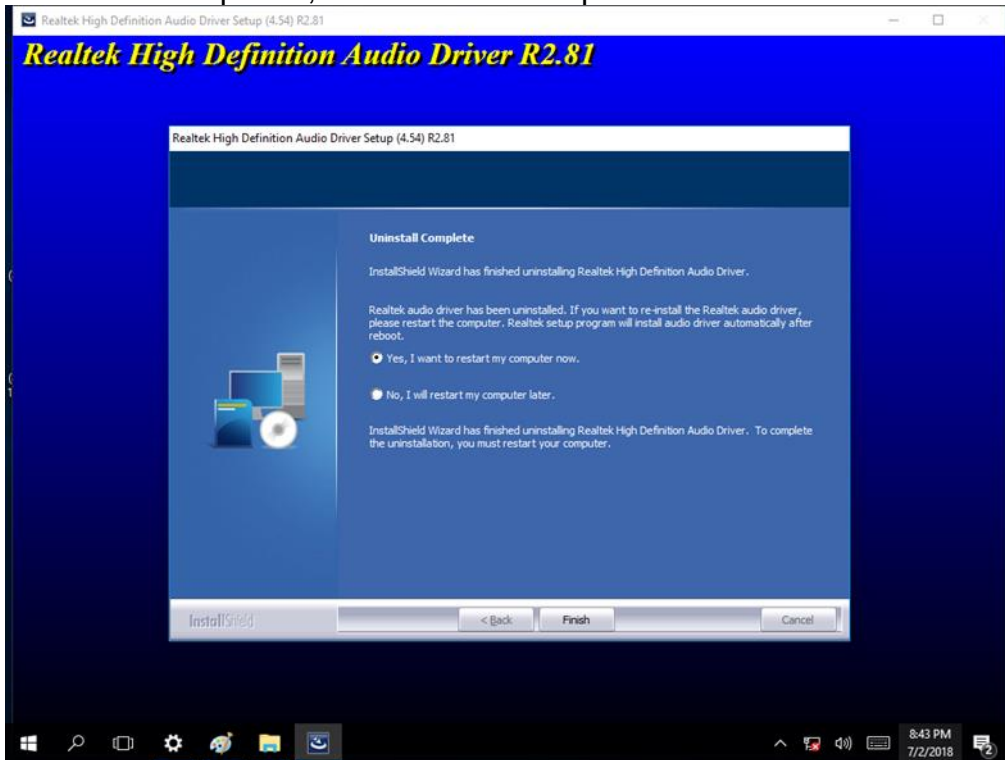

6.5 Ethernet Driver

Follow instructions below to install LAN driver.

1. Open the Driver CD (included in the package) and select **LAN** driver.

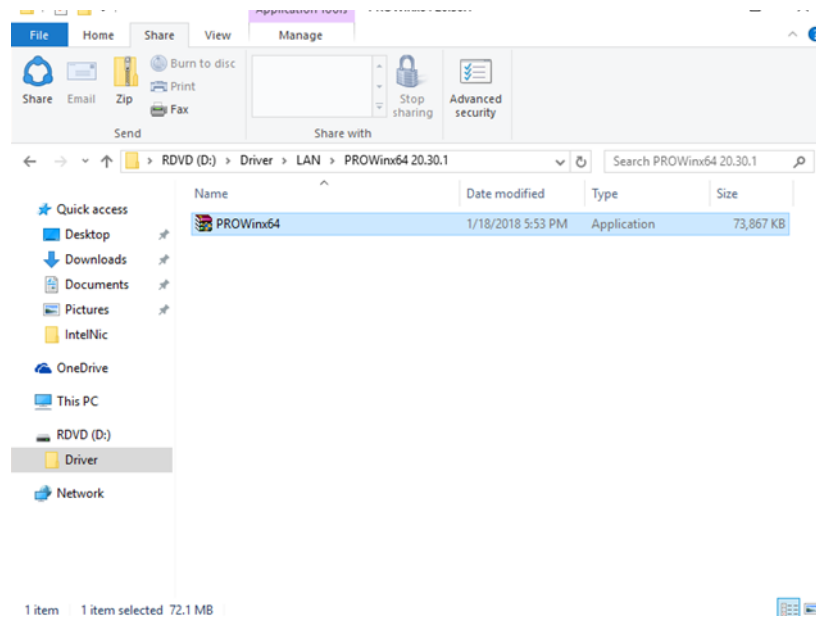

2. When compression is complete, select **Next**.

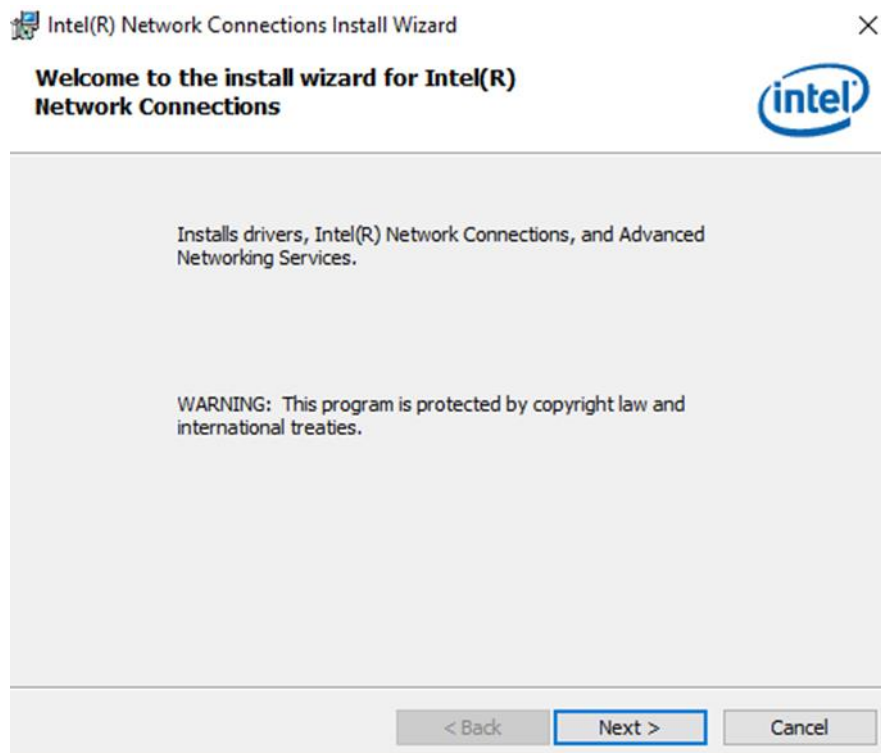

3. Read the license agreement, and then select **Next**.

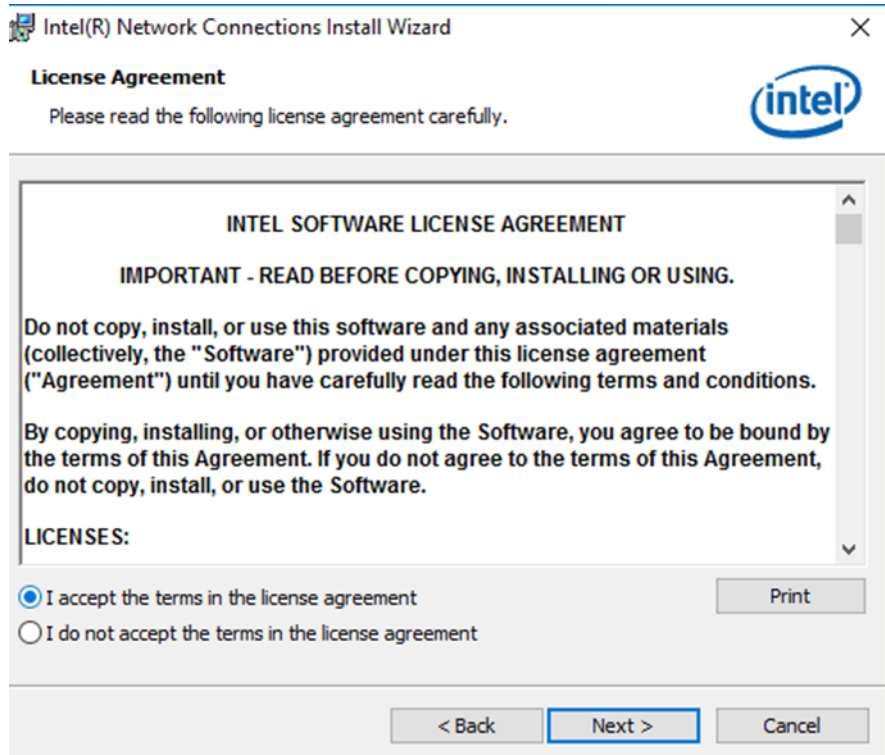

4. System displays the installed packages, select **Next**.

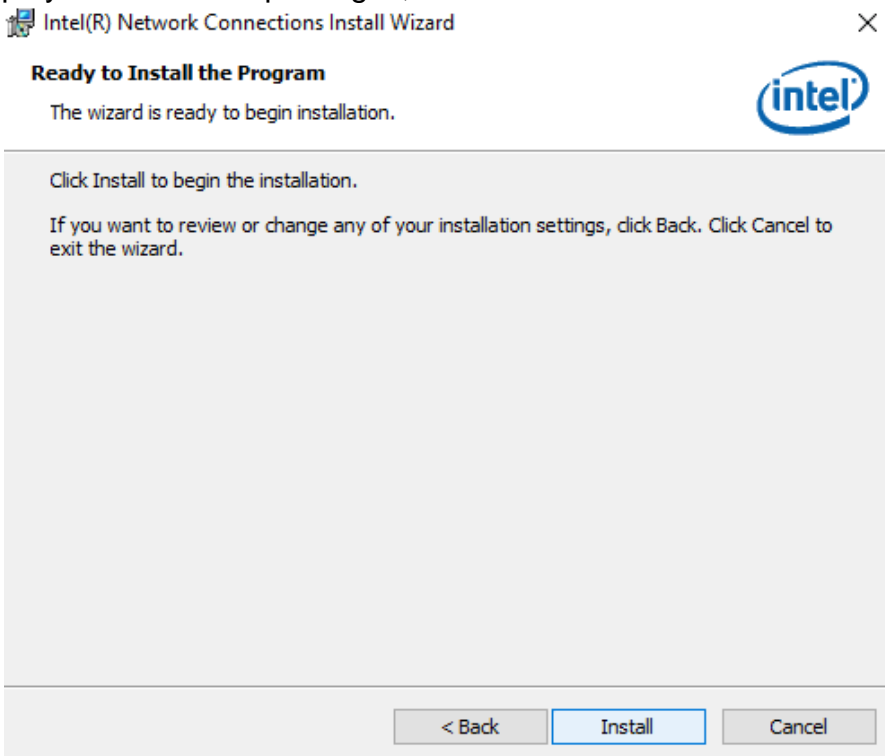

5. Confirm the installation, select **Install** to start the installation.

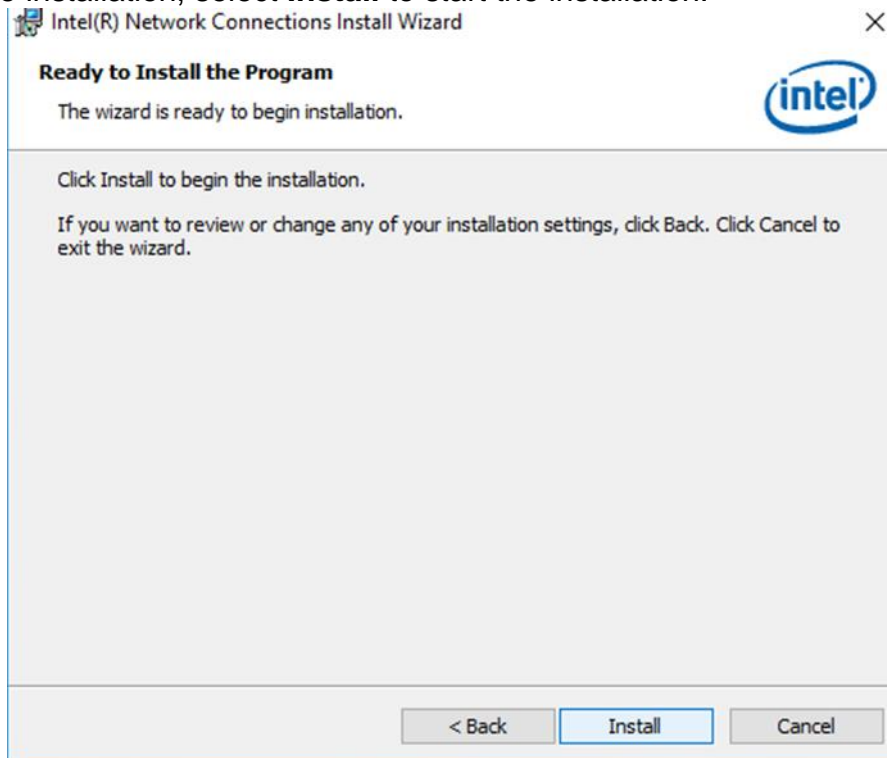

6. When installation is completed, select **Finish** to close the window.

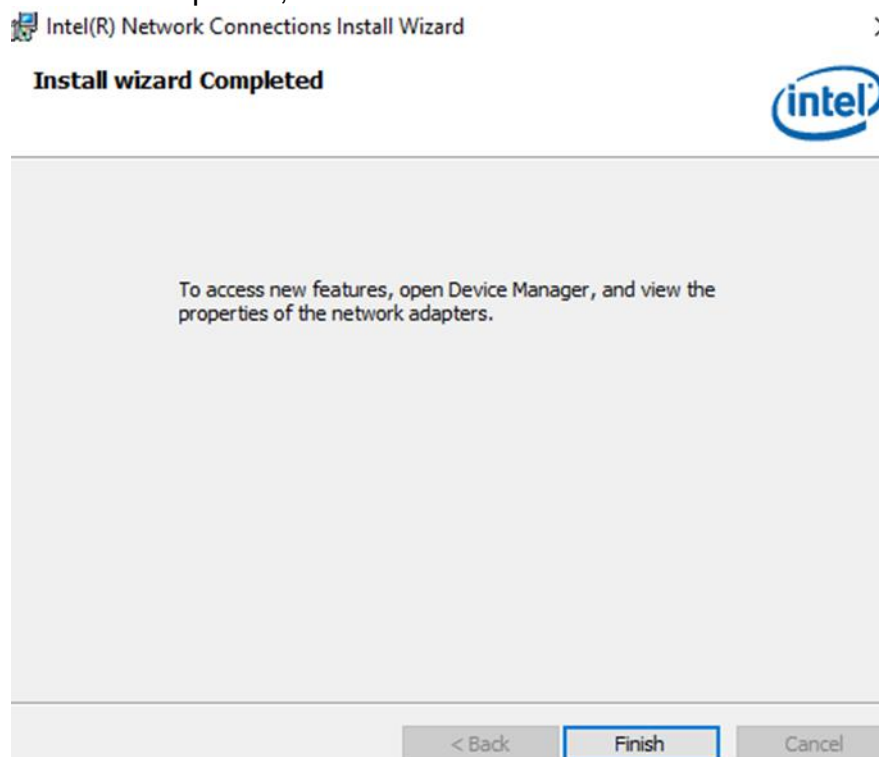

6.6 Watchdog Driver Installation

For more details about Winmate Watchdog, please download Watchdog Guide from Winmate Downloads Center [here](#).

Follow instructions below to install **Watchdog** driver.

1. Type "cmd" in the run box then the cmd.exe will appear in programs.

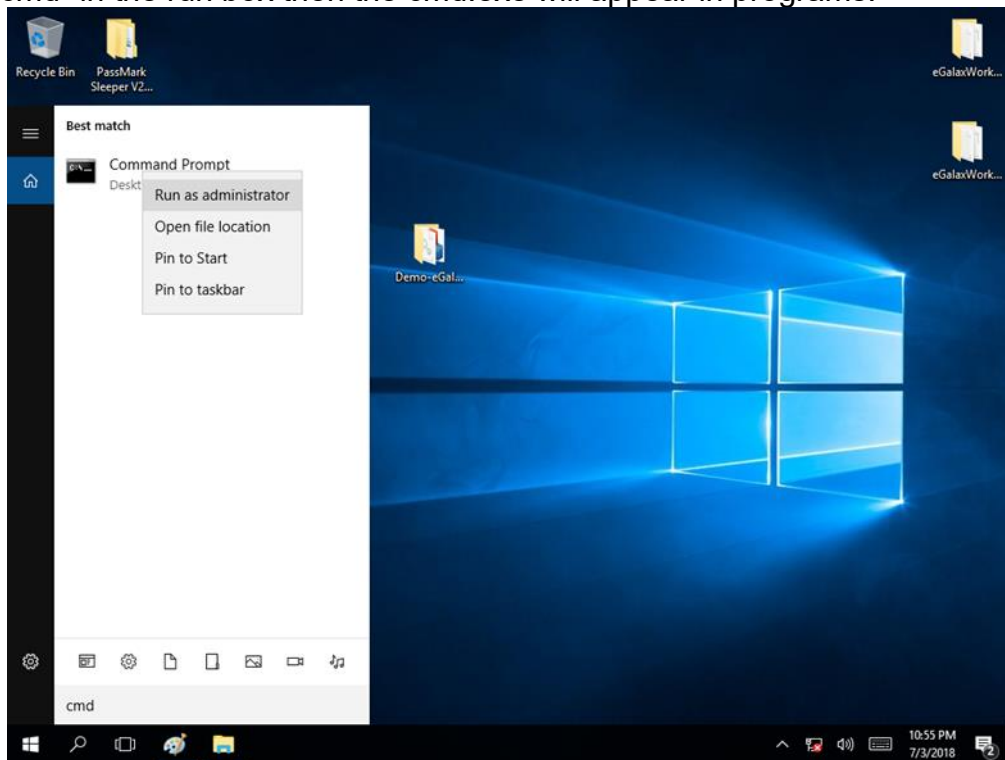

2. Right click on the cmd.exe and click on "Run as administrator" to start
3. Open the Driver CD (included in the package) and select Watchdog driver.

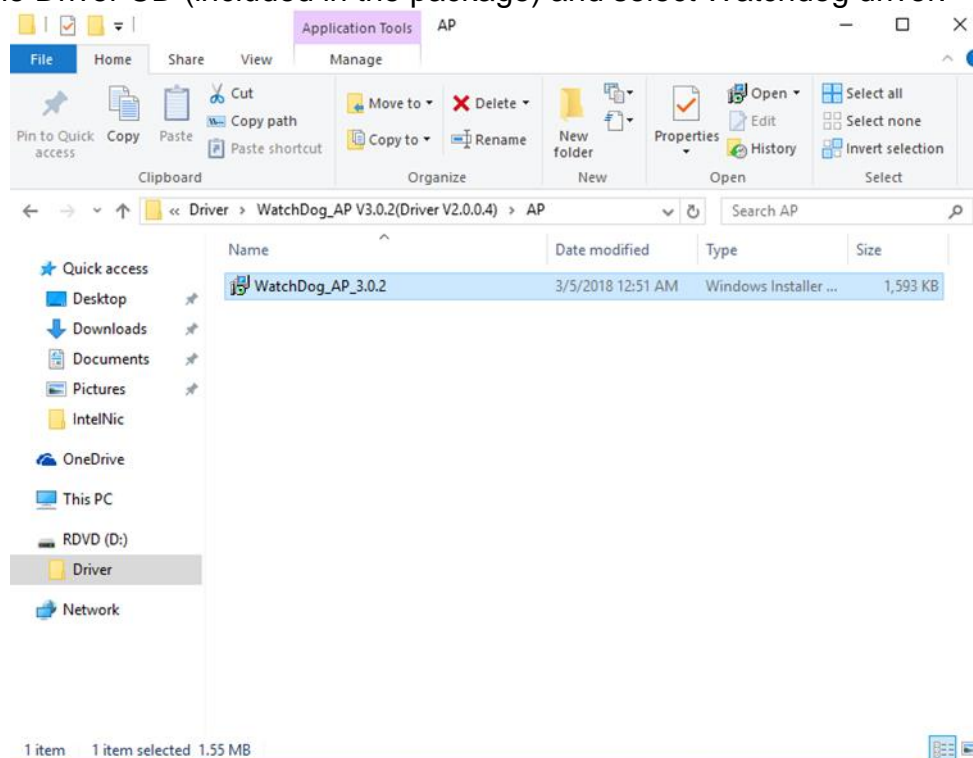

4. When Windows Security dialog appear, select **install** to continue the Installation.

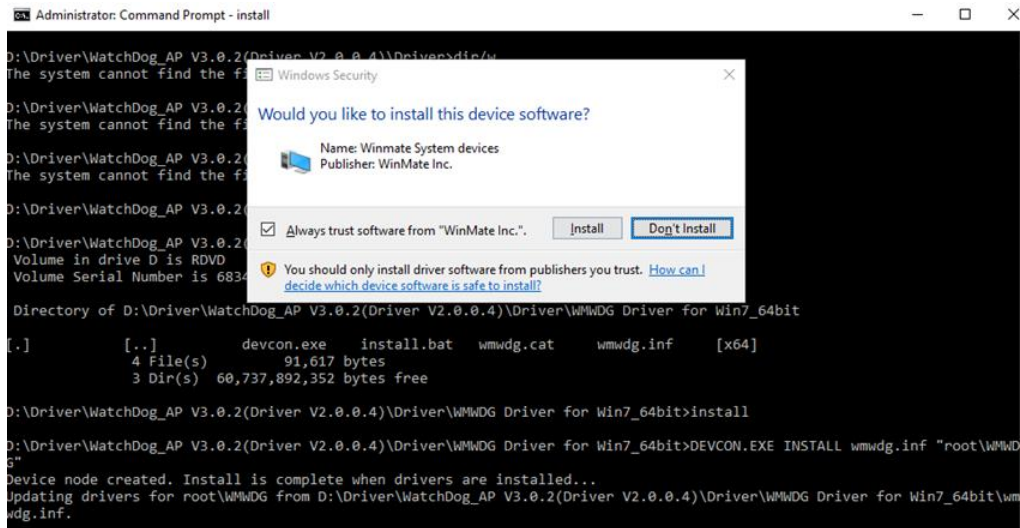

The screenshot shows a Windows Security dialog box titled "Would you like to install this device software?". The dialog box displays the name "Winmate System devices" and the publisher "WinMate Inc.". There is a checked box for "Always trust software from 'WinMate Inc.'." and two buttons: "Install" and "Don't Install". Below the dialog box, a Command Prompt window shows the directory listing for "D:\Driver\WatchDog_AP V3.0.2(Driver V2.0.0.4)\Driver\WMWDG Driver for Win7_64bit". The directory listing shows files: devcon.exe (91,617 bytes), install.bat, wmwgd.cat, and wmwgd.inf (x64). There are also 3 directories. The Command Prompt shows the command "install" and the output "Device node created. Install is complete when drivers are installed...".

5. Wait for installation to complete. When installation is complete, press any key to close.

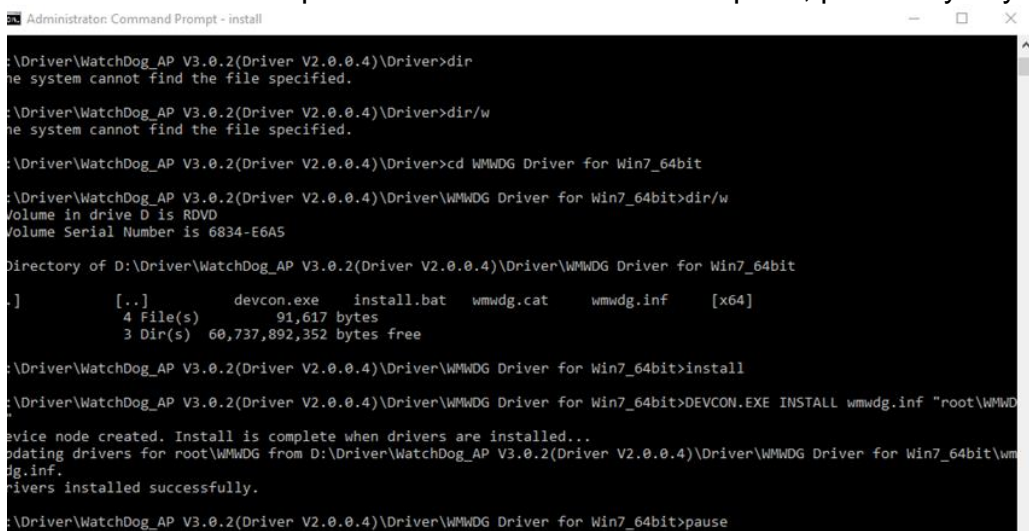

The screenshot shows a Command Prompt window titled "Administrator: Command Prompt - install". The Command Prompt shows the directory listing for "D:\Driver\WatchDog_AP V3.0.2(Driver V2.0.0.4)\Driver\WMWDG Driver for Win7_64bit". The directory listing shows files: devcon.exe (91,617 bytes), install.bat, wmwgd.cat, and wmwgd.inf (x64). There are also 3 directories. The Command Prompt shows the command "install" and the output "Device node created. Install is complete when drivers are installed...".

6. Open the Driver CD (included in the package) and select **Watchdog AP**.

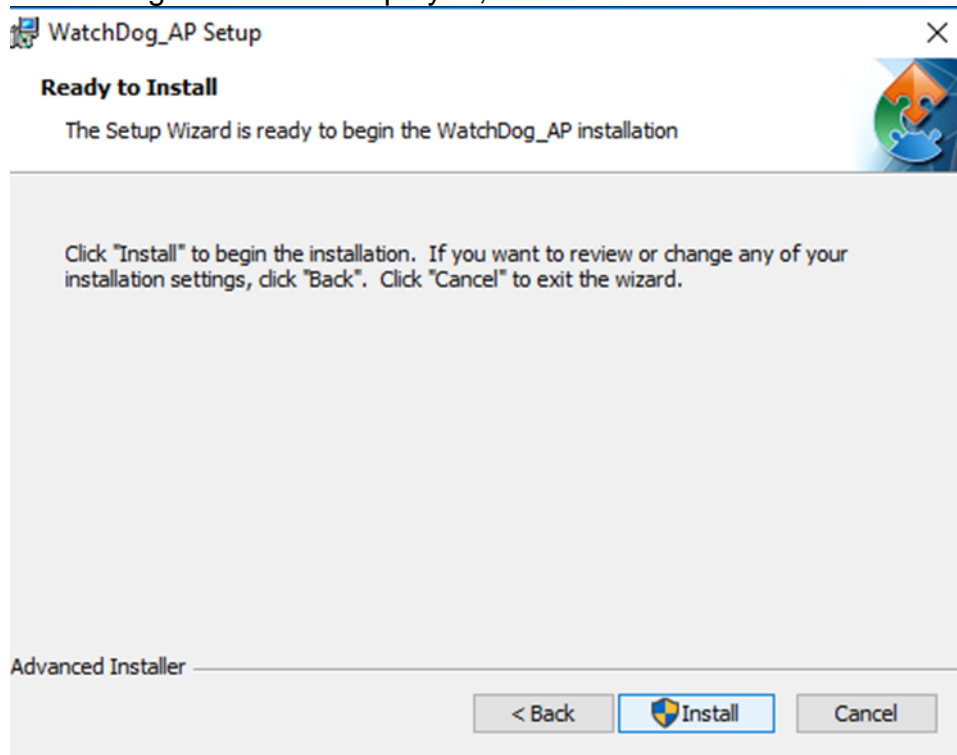
7. Select **Next**.8. The installed storage location is displayed, select **Next** to continue.9. Select **Next** to start the installation.

10. When installation is completed, select **Finish** to close the window.

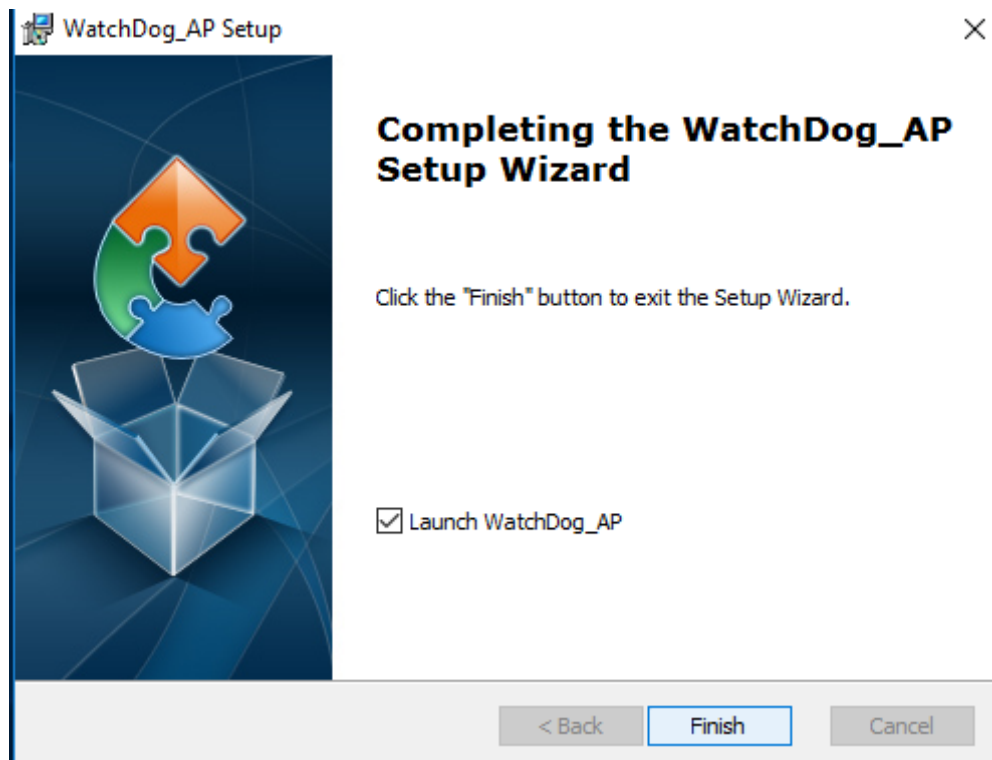

6.7 Digital IO Driver Installation

For more details about Winmate Watchdog, please download Digital IO Guide from Winmate Downloads Center:

Follow instructions below to install **Digital IO** river.

1. Type "cmd" in the run box then the cmd.exe will appear in programs.
2. Right click on the cmd.exe and click on "Run as administrator" to start

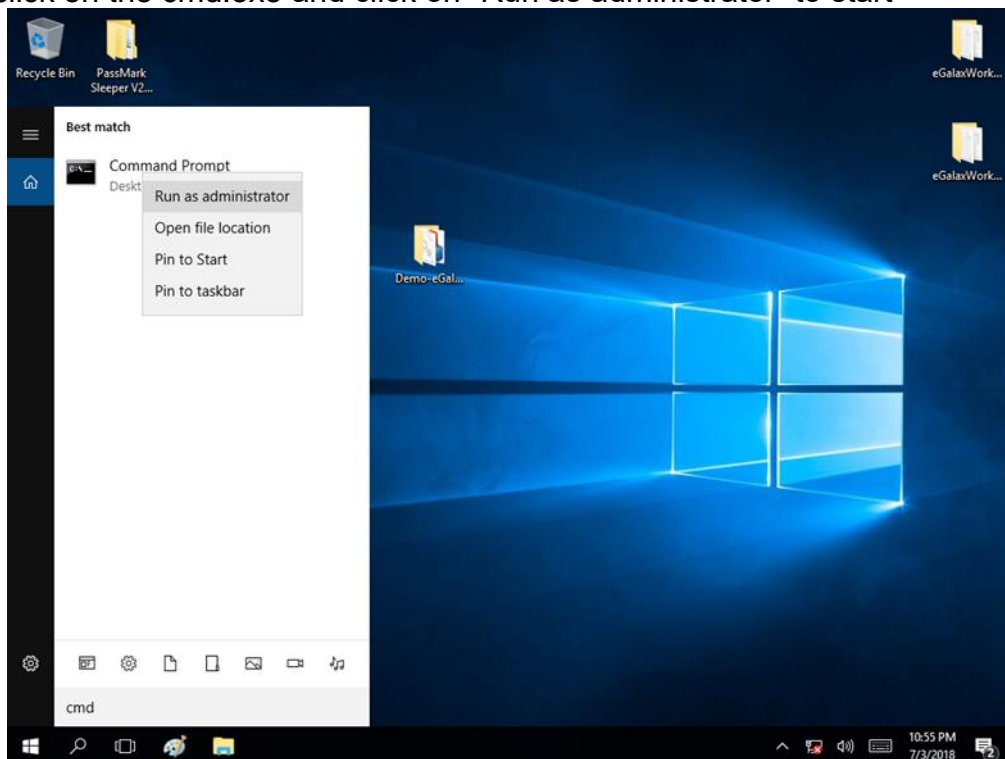

3. Open the Driver CD (included in the package) and select Digital IO driver.
4. When Windows Security dialog appear, select **install** to continue the Installation.
5. Wait for installation to complete. When installation is complete, press any key to close.

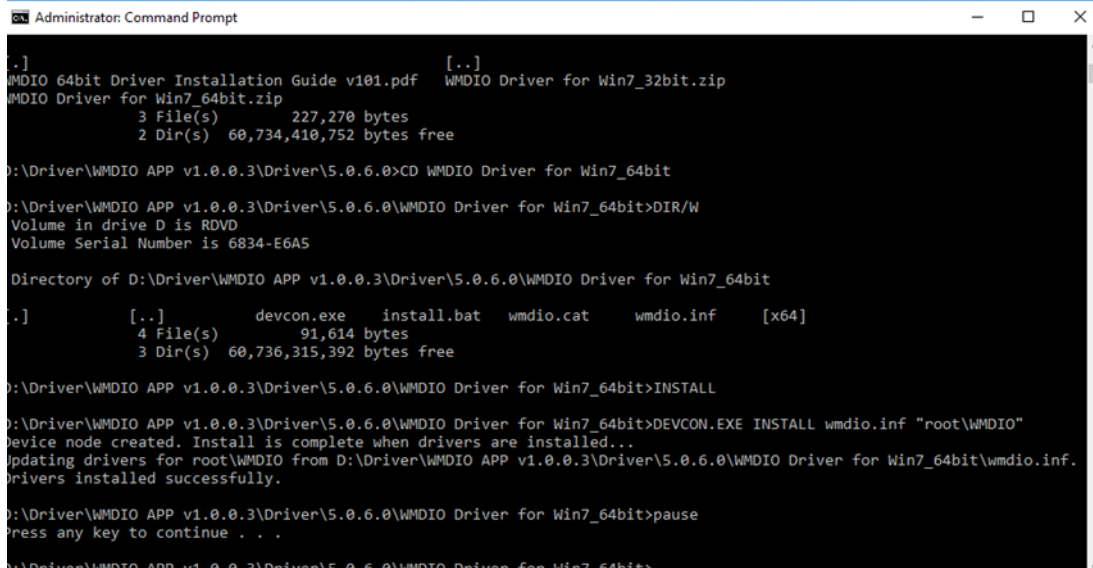

```
Administrator: Command Prompt
[.]
WMDIO 64bit Driver Installation Guide v101.pdf  WMDIO Driver for Win7_32bit.zip
WMDIO Driver for Win7_64bit.zip
      3 File(s)                227,270 bytes
      2 Dir(s)  60,734,410,752 bytes free

D:\Driver\WMDIO APP v1.0.0.3\Driver\5.0.6.0>CD WMDIO Driver for Win7_64bit
D:\Driver\WMDIO APP v1.0.0.3\Driver\5.0.6.0\WMDIO Driver for Win7_64bit>DIR/W
Volume in drive D is RDVD
Volume Serial Number is 6834-E6A5

Directory of D:\Driver\WMDIO APP v1.0.0.3\Driver\5.0.6.0\WMDIO Driver for Win7_64bit
[.]
[.]          devcon.exe  install.bat  wmdio.cat   wmdio.inf   [x64]
      4 File(s)                91,614 bytes
      3 Dir(s)  60,736,315,392 bytes free

D:\Driver\WMDIO APP v1.0.0.3\Driver\5.0.6.0\WMDIO Driver for Win7_64bit>INSTALL
D:\Driver\WMDIO APP v1.0.0.3\Driver\5.0.6.0\WMDIO Driver for Win7_64bit>DEVCON.EXE INSTALL wmdio.inf "root\WMDIO"
Device node created. Install is complete when drivers are installed...
Updating drivers for root\WMDIO from D:\Driver\WMDIO APP v1.0.0.3\Driver\5.0.6.0\WMDIO Driver for Win7_64bit\wmdio.inf.
Drivers installed successfully.

D:\Driver\WMDIO APP v1.0.0.3\Driver\5.0.6.0\WMDIO Driver for Win7_64bit>pause
Press any key to continue . . .
```

6. Open the Driver CD (included in the package) and select **Digital IO AP**.

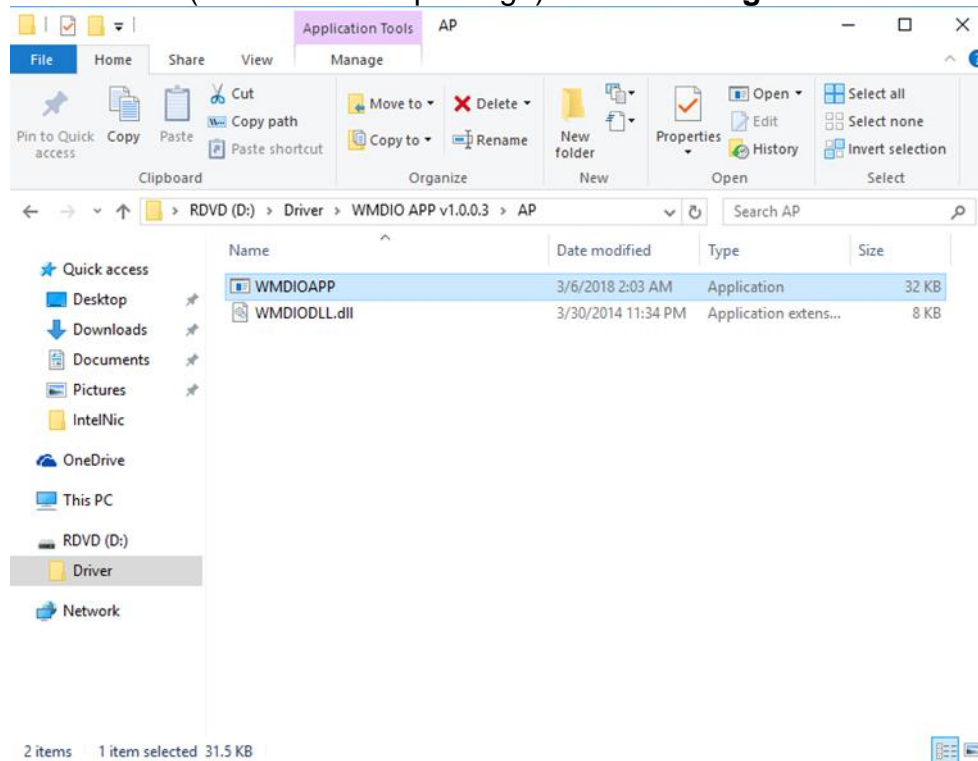

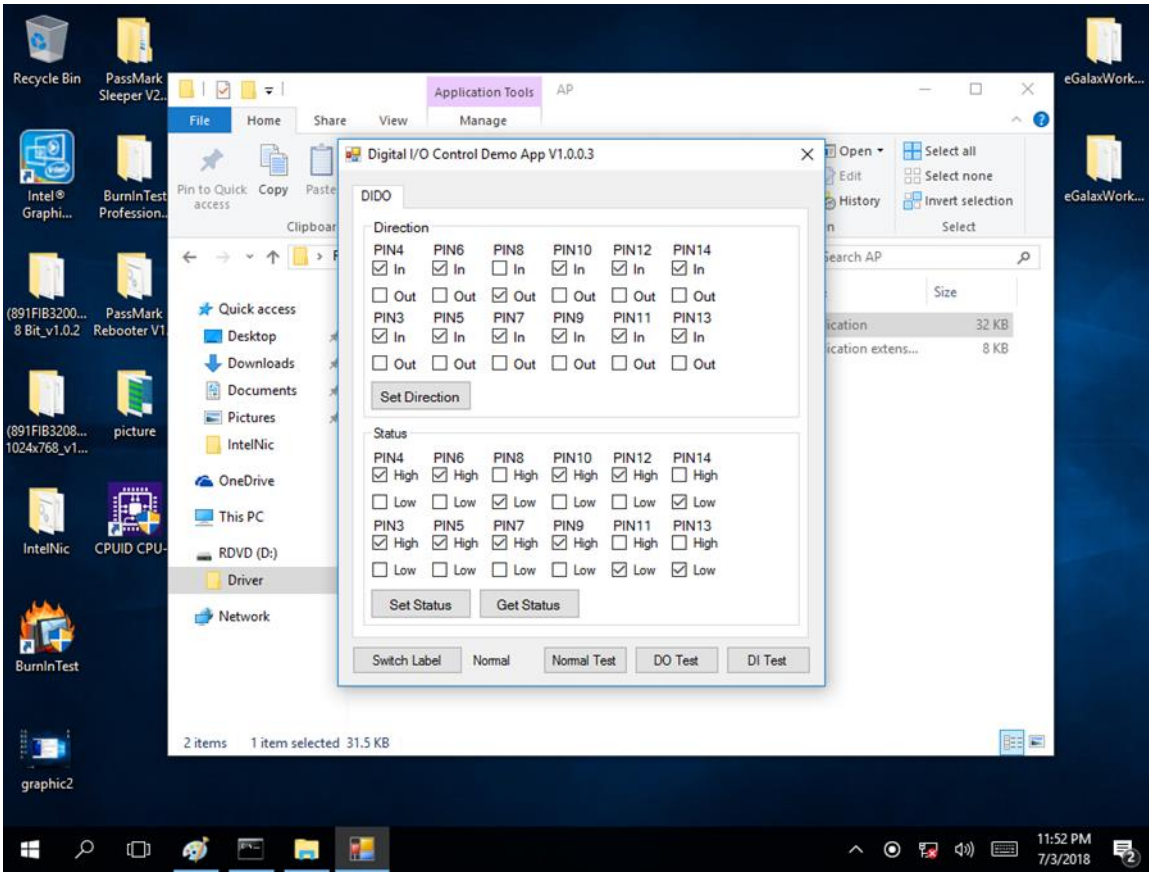

Chapter 7: Technical Support

This chapter includes the directory for technical support. Free technical support is available from our engineers every business day. We are always ready to give advice on application requirements or specific information on the installation and operation of any of our products.

7.1 Software Developer Support

Winmate provides the following SDK and Utilities for the GC Series Panel PC.

Item	File Type	Description
1	SDK	Watchdog SDK
2	Utility	Watchdog Utility

To find the Drivers and SDK, please refer to the Driver CD that comes in the package or contact us. Also, you can download drivers from Winmate Download Center.

Winmate Download Center

Go to www.winmate.com > Support > Download Center

Appendix

Appendix A: Product Specifications

	Model Name		
	R19IT7T-GCM1	W22IT7T-GCA3	W24IT7T-GCA2
Display			
Size/Type	19" TFT	21.5" TFT	23.8" TFT
Resolution	1280 x 1024	1920 x 1080	1920x1080
Brightness	250 nits	250 nits	250 nits
Contrast Ratio	1000 : 1 (typ.)	3000 : 1 (typ.)	3000 : 1 (typ.)
Viewing Angle	-85~85(H);-80~80(V)	-89~89(H);-89~89(V)	-89~89(H);-89~89(V)
Max Colors	16.7M	16.7M	16.7M
Touch	PCAP touch		
System			
Processor	Intel® Core™ i5-1135G7 (8M Cache, up to 4.20 GHz, Without vPro), Intel® Core™ i5-1145G7 (8M Cache, up to 4.40 GHz, With vPro) (Optional)		
Memory	1 x SO-DIMM, DDR4 3200 MHz, 4GB 8GB (Optional) 16GB (Optional) 32GB (Optional) 2x SO-DIMM, DDR4 3200 MHz, 4GB (Optional) 8GB (Optional) 16GB (Optional) 32GB (Optional) 64GB (Optional)		
Storage	1 x M.2 M-Key 2242 SATA SSD or 1 x M.2 M-key 2280 NVMe SSD 128GB 256GB(Optional) 512GB (Optional) 1TB (for NVMe) (Optional) 2TB (for NVMe) (Optional) 4TB (for NVMe) (Optional) 1x SATA III, up to 2TB (Optional)		
Ethernet controller	2 x Intel® Ethernet Controller		
Security	TPM 2.0		
OS	Windows 11 IoT Enterprise (Optional) Windows 11 pro 64 bit (Optional) Windows 10 IoT Enterprise (Optional) Linux Ubuntu 22.04 (Optional)		
IO Ports			
Power Input	1 x12 VDC Din 4 Pin Connector		
USB Port	4 x USB 3.2 Gen2x1 (Type-A)		
Serial	1 x RS232/422/485 (Default RS232) 1 x RS232		
Video	1 x DP 1.4 1 x HDMI 2.0 (Optional)		
Expansion Port	1 x M.2 2242/2280 Key M slot for SATA/NVMe SSD 1 x M.2 2230 Key E slot for Wifi (Optional)		
Audio	1 x Mic in 1 x Line-Out		
LAN	2 x Giga LAN RJ45 Connector		
Indicator	1 x LED Indicator for power 1 x LED Indicator for storage		
Brightness Knob	1 x Brightness Adjustment Knob		
Power			
Power Rating	12 V DC		

Adapter	12V 120W
Mechanical Specifications	
Cooling System	Fanless design
Mounting	Panel mount, VESA mount
Enclosure	Metal Housing with Plastic Bezel
Environment	
Operating Temperature	0°C to 50°C
Operating Humidity	10% to 90% (non-condensing)
Storage Temperature	-20°C to 60°C
IP Rating	Front IP65
Certification	
Certification	CE, FCC
Control	
Button	1 x Power Button 1 x Reset Button
Accessory	
Accessory	Adapter Power Cord User Manual (Handcopy)

Winmate Inc.
9F, No.111-6, Shing-De Rd., San-Chung District,
New Taipei City 24158, Taiwan, R.O.C
www.winmate.com

Copyright2023 © Winmate Inc. All rights reserved.

