

# ARCHMI-S-9XXD

10.1", 12.1", 12.1W", 15", 15.6", 17", 18.5", 19", 21.5", 23.8"  
Intel 12<sup>th</sup>/13<sup>th</sup> Gen. Fanless Industrial Compact Size Panel PC

## User Manual

**Release Date**

Dec. 2025

**Revision**

V1.7

©2025 Aplex Technology, Inc.

All Rights Reserved.

Published in Taiwan

Aplex Technology, Inc.

15F-1, No.186, Jian Yi Road, Zhonghe District, New Taipei City 235, Taiwan

Tel: 886-2-82262881 Fax: 886-2-82262883 URL: <https://www.aplex.com/>

# Revision History

Reversion	Date	Description
1.0	2024/10/28	Initiation
1.1	2024/11/13	Revised chapter 1.2 Certification description
1.2	2024/12/31	<ol style="list-style-type: none"><li>1. Added page7 storage * Notice 1</li><li>2. Revised Operating Temperature</li><li>3. Revised Figure 10 to ARCHMI-S-924DP(H)</li><li>4. Added 1.11 SSD heatsink kit installation guide</li><li>5. Added 2.4 Jumpers Setting and Connectors: 27. AUTO_BTN</li><li>6. Added 1.5 Power Consumption</li><li>7. Updated 1.2 CPU description</li></ol>
1.3	2025/1/10	Updated 1.5 Power Consumption
1.4	2025/2/13	Updated 1.5 Power Consumption
1.5	2025/10/02	Revised Operating Temperature: 10.1" ~19" LCD : default is 0-50 °C, -20~60 °C is option 10.1"~19" High Brightness 、 21.5" and 23.8" LCD : 0°C to 50°C
1.6	2025/11/20	Add Secure Boot Keys
1.7	2025/12/05	<ol style="list-style-type: none"><li>1.Add i7-1255U, i3-1315UE, i5-1335UE CPU</li><li>2.Supports DDR5-4800</li></ol>

## Warning!

---

This equipment generates uses and can radiate radio frequency energy and if not installed and used in accordance with the instructions manual, it may cause interference to radio communications. It has been tested and found to comply with the limits for a Class A computing device pursuant to FCC Rules, which are designed to provide reasonable protection against such interference when operated in a commercial environment. Operation of this equipment in a residential area is likely to cause interference in which case the user at his own expense will be required to take whatever measures may be required to correct the interference.

Electric Shock Hazard – Do not operate the machine with its back cover removed. There are dangerous high voltages inside.

### Caution

**Risk of explosion if the battery is replaced with an incorrect type.**

**Batteries should be recycled where possible. Disposal of used batteries must be in accordance with local environmental regulations.**

### Disclaimer

**This information in this document is subject to change without notice. In no event shall Apex Technology Inc. be liable for damages of any kind, whether incidental or consequential, arising from either the use or misuse of information in this document or in any related materials.**

## Safety Precautions

Follow the messages below to prevent your systems from damage:

- ◆ Avoid your system from static electricity on all occasions.
- ◆ Prevent electric shock. Don't touch any components of this card when the card is power-on. Always disconnect power when the system is not in use.
- ◆ Disconnect power when you change any hardware devices. For instance, when you connect a jumper or install any cards, a surge of power may damage the electronic components or the whole system.

# Table of Contents

<b>Revision History</b> .....	<b>1</b>
<b>Warning!</b> .....	<b>2</b>
<b>Safety Precautions</b> .....	<b>3</b>
<b>Chapter 1 System Product</b> .....	<b>6</b>
1.1 Features .....	6
1.2 Specifications .....	6
1.3 Display .....	8
1.4 Mechanical .....	10
1.5 Power Consumption .....	10
1.6 Dimensions .....	11
1.7 Brief Description of ARCHMI-S-9XXB Series.....	16
1.8 Installation of Memory and Storage.....	17
1.9 VESA Mounting.....	19
1.10 Panel Mounting .....	20
1.11 SSD heatsink kit installation guide .....	20
<b>Chapter 2 Hardware</b> .....	<b>22</b>
2.1 Motherboard Specifications.....	22
2.2 Board Dimensions .....	24
2.3 Jumpers and Connectors Location.....	24
2.4 Jumpers Setting and Connectors .....	26
<b>Chapter 3 BIOS Setup Description</b> .....	<b>34</b>
<b>Chapter 4 Installation of Drivers</b> .....	<b>83</b>

# List of Figures

## **Figures**

---

Figure 1: Dimensions of ARCHMI-S-910DP/DR(H).....	11
Figure 2: Dimensions of ARCHMI-S-912DP/DR(H).....	11
Figure 3: Dimensions of ARCHMI-S-912WDP/DR(H).....	12
Figure 4: Dimensions of ARCHMI-S-915DP/DR(H).....	12
Figure 5: Dimensions of ARCHMI-S-916DP/DR(H).....	13
Figure 6: Dimensions of ARCHMI-S-917DP/DR(H).....	13
Figure 7: Dimensions of ARCHMI-S-918DP/DR(H).....	14
Figure 8: Dimensions of ARCHMI-S-919DP/DR(H).....	14
Figure 9: Dimensions of ARCHMI-S-921DP/DR(H).....	15
Figure 10: Dimensions of ARCHMI-S-924DP(H).....	15
Figure 11: Front View of ARCHMI-S-916D.....	16
Figure 12: Rear View of ARCHMI-S-916D.....	16
Figure 13: ARCHMI-S-9XXD VESA Mounting.....	18
Figure 14: ARCHMI-S-9XXD PANEL Mounting.....	19

## 1.1 Features

- Intel 12<sup>th</sup> / 13<sup>th</sup> Gen. i3-1215U, i5-1235U, i7-1255U, i3-1315UE, i5-1335UE (Alder lake-U)
- 10.1” to 23.8” Industrial Compact Size Panel PC
- ARCHMI-Series IP66 Compliant Aluminum Front Bezel
- Support 1 x DDR5 4800MHz SO-DIMM, Up to 48G
- Power Input: DC 9-36V
- Support Resistive touch screen (Model: R) and Projected Capacitive Multi-touch screen (Model: P) by SKU
- Support High Brightness LCD Version for Optional
- Support Auto-Dimming, Optional
- Fanless Design

## 1.2 Specifications

ARCHMI-S-9XXD Series	
<b>System</b>	
CPU	12th /13th Gen. Intel® Core™ i3/i5/i7 SoC : Intel Core i3-1215U 2P/4E, P-core: 4.4GHz, E-core: 3.3GHz, 15W TDP (Default) Intel Core i5-1235U 2P/8E, P-core: 4.4GHz, E-core: 3.3GHz, 15W TDP (Optional) Intel Core i7-1255U 2P/8E, P-core: 4.7GHz, E-core: 3.3GHz, 15W TDP (Optional) Intel Core i3-1315UE 2P/4E, P-core: 4.5GHz, E-core: 3.3GHz, 15W TDP (Optional) Intel Core i5-1335UE 2P/8E, P-core: 4.5GHz, E-core: 3.3GHz, 15W TDP (Optional)
Chipset	Integrated with SoC
BIOS	AMI UEFI BIOS
Memory	1 x DDR5 4800MHz SO-DIMM, up to 48GB
Graphic	Intel® UHD Graphics
<b>IO Port</b>	
USB	2 x Type-A USB 3.0 2 x Type-A USB 2.0
Serial	2 x DB9 Type RS-232/422/485(COM1/COM2, BIOS selection) 1 x DB9 Type RS-232(COM3)
LAN	1 x RJ45 Type Intel I210AT 1GbE LAN 1 x RJ45 Type Intel I229LM 1GbE LAN
Power	1 x pin3 Terminal Block Type, DC 9-36V Power input
<b>Storage Space</b>	
Storage	1 x M.2 Key-M Slot for NVME (PCIe x1, 2280) * Notice 1

<b>Expansion</b>	
Expansion Slot	1 x M.2 Key-E Slot (Support WIFI+BT, 2230) 1 x M.2 Key-B Slot (Support 4G/5G, 3042/3052)
<b>Others</b>	
TPM	Onboard TPM2.0 SPI I/F TPM IC
Watchdog Timer	1 ~ 255 sec (system)
Wake on LAN	Support WOL
<b>Antenna</b>	
Antenna	Provide 2 x external antenna holes
<b>Power</b>	
Power Input	1 x pin3 Terminal Block Type, DC 9-36V power input, Power on AT/ATX supported, default AT mode
<b>Mechanical</b>	
Mechanical Construction	Aluminum die-casting chassis
Mounting	Panel Mount VESA 100 x 100 mm
IP Rating	IP66 Front Bezel Design
<b>Operating System Support</b>	
OS Support	Windows 10 IoT Enterprise 2021 LTSC Windows 11 (21H2) or later Linux 24.04 or later
<b>Environmental</b>	
Operating Temperature	10.1"~19" LCD : default is 0-50 °C, -20~60 °C is option 10.1"~19" High Brightness 、 21.5" and 23.8" LCD : 0°C to 50°C
Storage Temperature	-30~70°C
Humidity	10 to 95% @ 40°C, non-condensing
Certification	CE / FCC Class A

**\*Notice 1:**

We recommend purchasing the SSD + Heatsink from APLEX.

If you purchase an SSD locally, please remember to install a heatsink kit to prevent overheating, which may cause system instability.

APLEX M.2 2280 Heatsink Dimensions: 76 x 24 x 6.3mm

APLEX Tested M.2 Module: The SSD module we tested is Transcend's TSXXXGMTE672A series.

# 1.3 Display

## 1.3.1 Standard LCD

	<b>ARCHMI-S-910DP/R</b>	<b>ARCHMI-S-912DP/R</b>	<b>ARCHMI-S-912WDP/R</b>	<b>ARCHMI-S-915DP/R</b>	<b>ARCHMI-S-916DP/R</b>
Display Type	10.1" TFT LCD	12.1" TFT LCD	12.1" Wide TFT LCD	15" TFT LCD	15.6W" TFT LCD
Max. Resolution	1280 x 800	800 x 600(SVGA) 1024 x 768(XGA)	1280 x 800	1024 x 768	1920x1080
Max. Color	16.7M	16.2M	16.7M	16.7M	16.7M
Luminance(cd/m <sup>2</sup> )	350	450(SVGA) 500(XGA)	400	350	500
Contrast Ratio	800 : 1	1500:1(SVGA) 1000:1(XGA)	1200:1	1000:1	1000:1
Viewing angle(H/V)	170/170	178/178	170 /170	178/178	178 /178
MTBF(Hrs)	30,000	50,000(SVGA) 30,000(XGA)	50,000	50,000	50,000

	<b>ARCHMI-S-917DP/R</b>	<b>ARCHMI-S-918DP/R</b>	<b>ARCHMI-S-919DP/R</b>	<b>ARCHMI-S-921DP/R</b>	<b>ARCHMI-S-924DP</b>
Display Type	17" TFT LCD	18.5" TFT LCD	19" TFT LCD	21.5" TFT LCD	23.8" TFT LCD
Max. Resolution	1280 x 1024	1920 x 1080	1280 x 1024	1920 x 1080	1920 x 1080
Max. Color	16.7M	16.7M	16.7M	16.7M	16.7M
Luminance(cd/m <sup>2</sup> )	350	350	350	300	250
Contrast Ratio	1000:1	1000:1	1000:1	1000:1	3000:1
Viewing angle(H/V)	160/140	178/178	170/160	178/178	178/178
MTBF(Hrs)	50,000	50,000	50,000	50,000	30,000

### 1.3.2 High Brightness LCD

	<b>ARCHMI-S-910DP/R(H)</b>	<b>ARCHMI-S-912DP/R(H)</b>	<b>ARCHMI-S-912WDP/R(H)</b>	<b>ARCHMI-S-915DP/R(H)</b>	<b>ARCHMI-S-916DP/R(H)</b>
Display Type	10.1" TFT LCD	12.1" TFT LCD	12.1" Wide TFT LCD	15" TFT LCD	15.6W" TFT LCD
Max. Resolution	1280 x 800	800 x 600(SVGA) 1024 x 768(XGA)	1280 x 800	1024 x 768	1920 x 1080
Max. Color	16.7M	16.7M(SVGA) 16.2M(XGA)	16.2M	16.7M	16.7M
Luminance(cd/m <sup>2</sup> )	1000				
Contrast Ratio	800:1	1000:1	1300:1	3000:1	1000:1
Viewing angle(H/V)	178 /178	140 /120	170/ 170	176 / 176	176 / 176
MTBF(Hrs.)	50,000	50,000(SVGA) 70,000(XGA)	50,000	70,000 (XGA)	50,000

	<b>ARCHMI-S-917DP/R(H)</b>	<b>ARCHMI-S-918DP/R(H)</b>	<b>ARCHMI-S-919DP/R(H)</b>	<b>ARCHMI-S-921DP/R(H)</b>	<b>ARCHMI-S-924DP(H)</b>
Display Type	17" TFT LCD	18.5" TFT LCD	19" TFT LCD	21.5" TFT LCD	23.8" TFT LCD
Max. Resolution	1280 x 1024	1920 x 1080	1280 x 1024	1920 x 1080	1280 x 1024
Max. Color	16.7M	16.7M	16.7M	16.7M	16.7M
Luminance(cd/m <sup>2</sup> )	1000				
Contrast Ratio	3000:1	1000:1	800:1	1000:1	1000:1
Viewing angle(H/V)	176/176	170/160	178/178	178/178	178/178
MTBF(Hrs)	50,000	50,000	30,000	30,000	30,000

All product specifications are subject to change without notice, \* identify as optional function

## 1.4 Mechanical

	<b>ARCHMI-S-910DP/R(H)</b>	<b>ARCHMI-S-912DP/R(H)</b>	<b>ARCHMI-S-912WDP/R(H)</b>	<b>ARCHMI-S-915DP/R(H)</b>	<b>ARCHMI-S-916DP/R(H)</b>
Mounting	VESA Mount 100 x 100 mm				
Dimensions(mm)	285x189x75	319x244.9x77	328x227x78	410.2x310.2x78.7	412x277.5x78
Net Weight(Kg)	2.61	3.5	TBD	5	4.2

	<b>ARCHMI-S-917DP/R(H)</b>	<b>ARCHMI-S-918DP/R(H)</b>	<b>ARCHMI-S-919DP/R(H)</b>	<b>ARCHMI-S-921DP/R(H)</b>	<b>ARCHMI-S-924DP(H)</b>
Mounting	VESA Mount 100 x 100 mm				
Dimensions(mm)	439x348x82	499.6x314.6x82	468x380x82	557.3x362.3x81.4	640x395x88
Net Weight	TBD	TBD	TBD	7.4	9.44

## 1.5 Power Consumption

Max power consumption of each model under Window 10

Model	Max Power Consumption
ARCHMI-S-910D	34W
ARCHMI-S-912D	42W
ARCHMI-S-912WD	37W
ARCHMI-S-915D	44W
ARCHMI-S-916D	43W
ARCHMI-S-917D	41W
ARCHMI-S-918D	44W
ARCHMI-S-919D	44W
ARCHMI-S-921D	44W
ARCHMI-S-924D	52W

\* To record power consumed when system has full loading with external devices attached.

\* Power consumption may have 10% tolerance difference due to different MB, parts, test instrument, and so on.

\* We suggest using the adapter that APLEX approved. If you would like to adopt your own power supply or adapter, please add another 20-30% from the above power consumption to make sure the system can work stable.

# 1.6 Dimensions

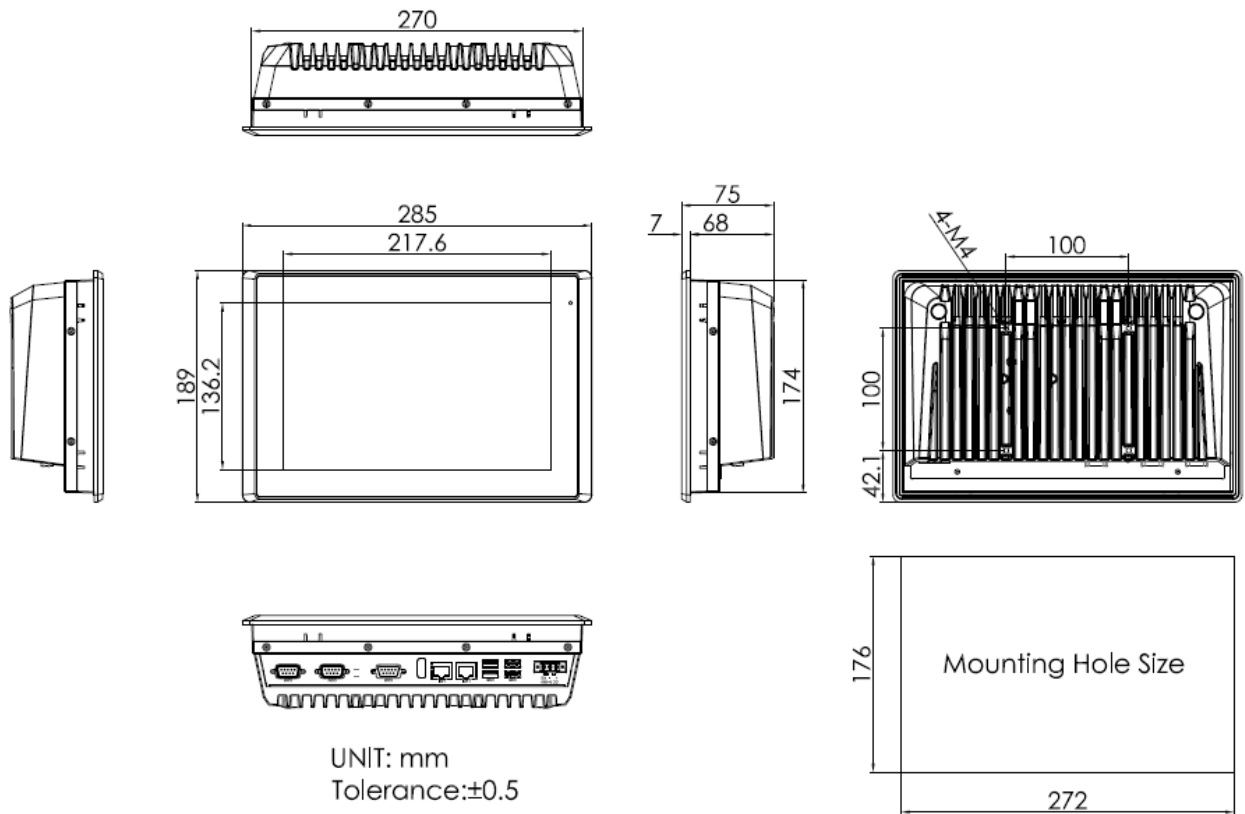

Figure 1 Dimensions of ARCHMI-S-910DP/R(H)

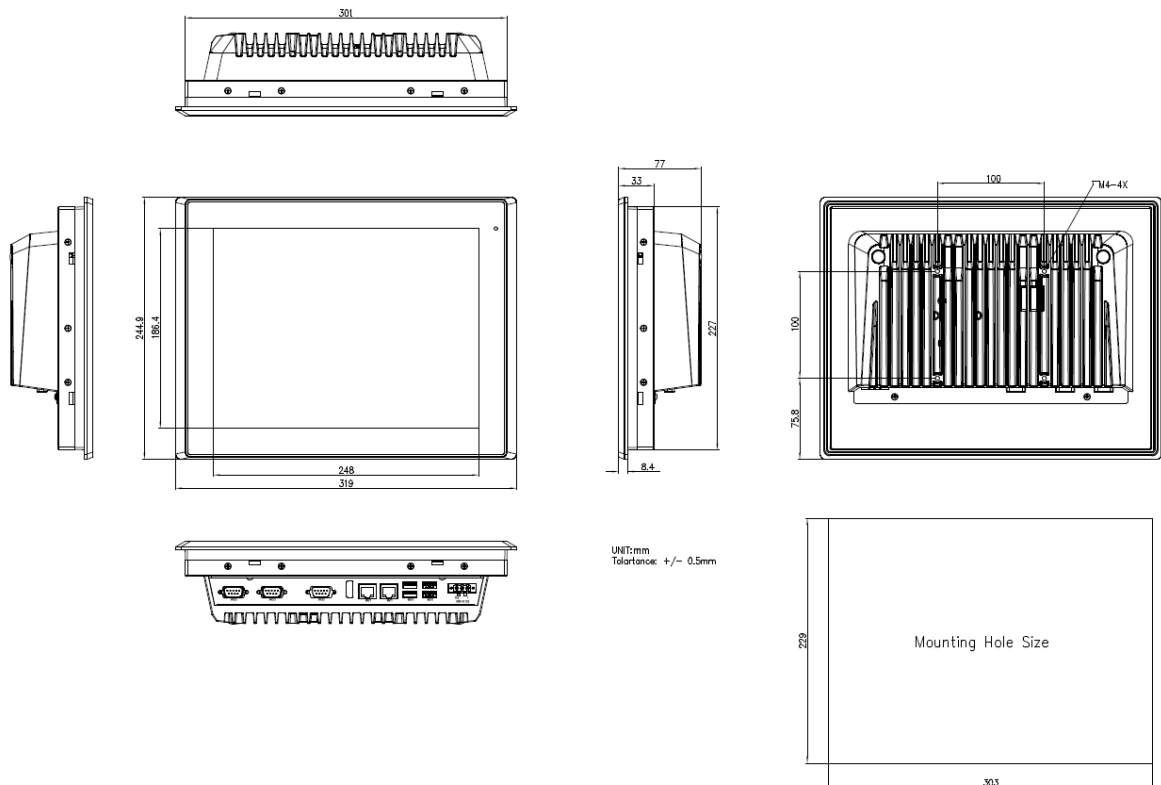

Figure 2 Dimensions of ARCHMI-S-912DP/R(H)

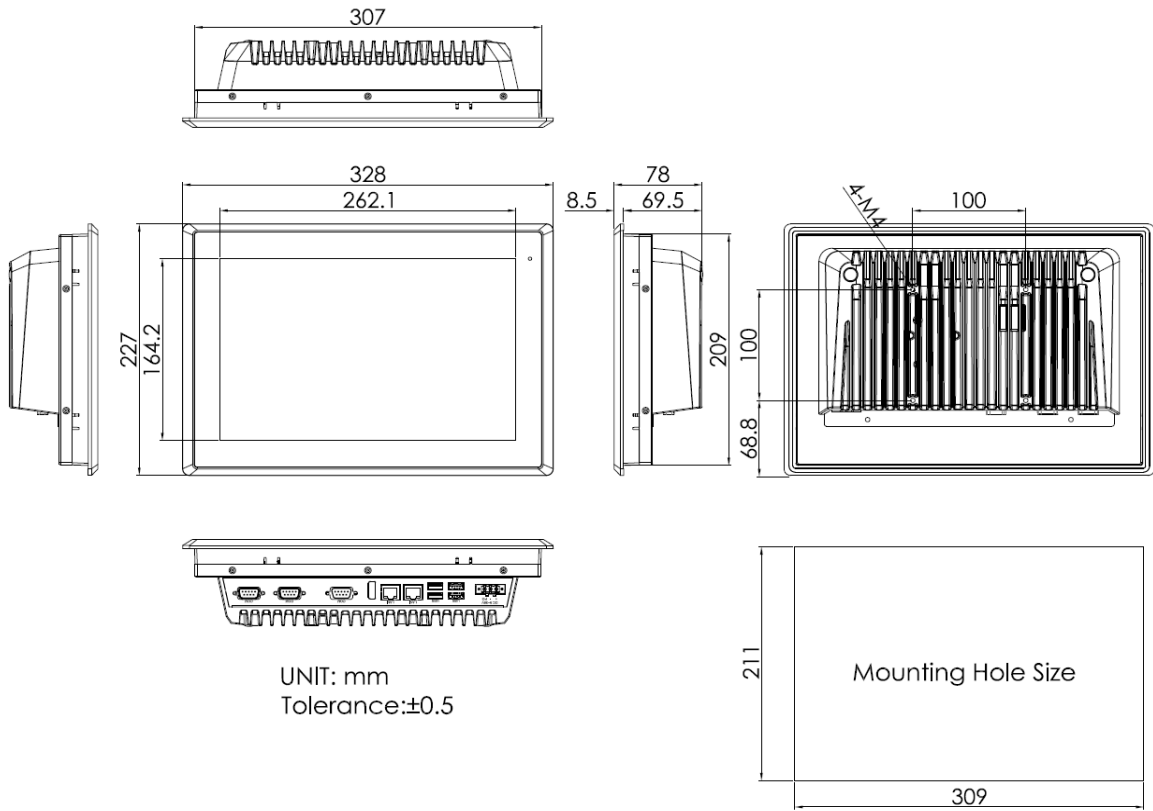

Figure 3 Dimensions of ARCHMI-S-912WDP/R(H)

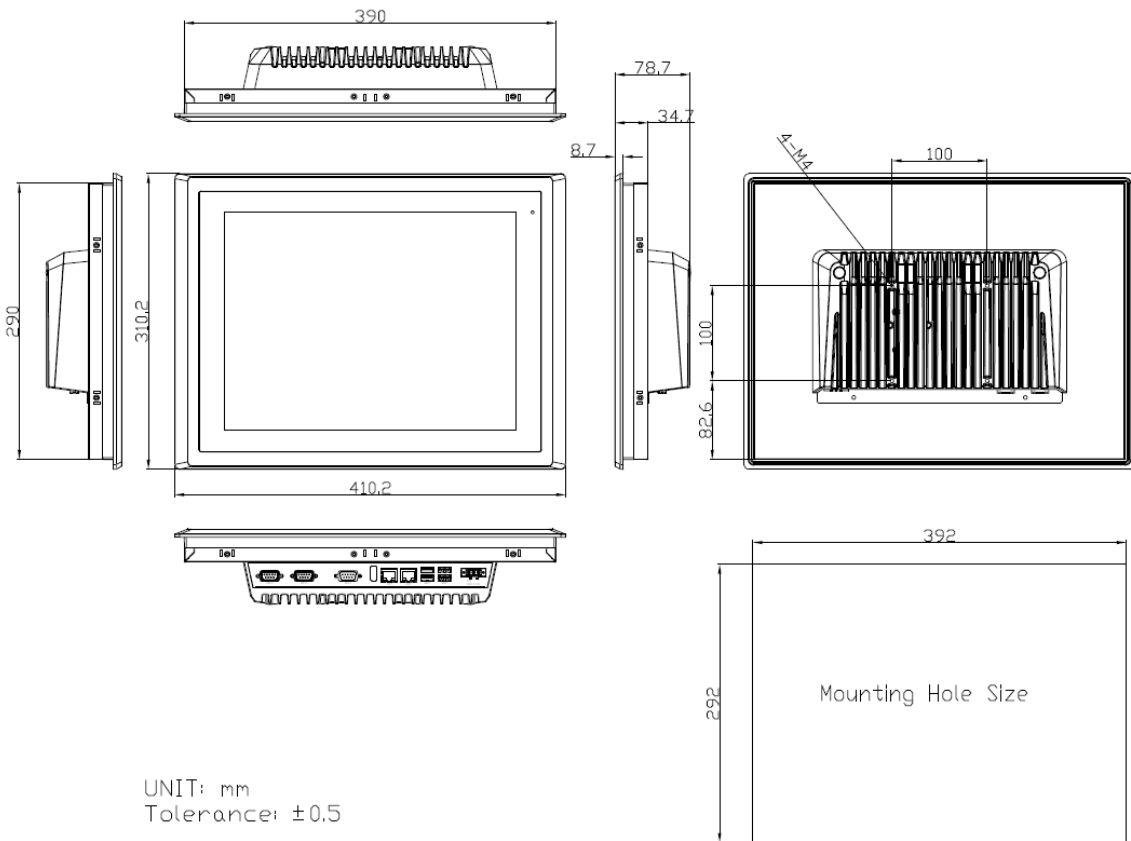

Figure 4 Dimensions of ARCHMI-S-915DP/R(H)

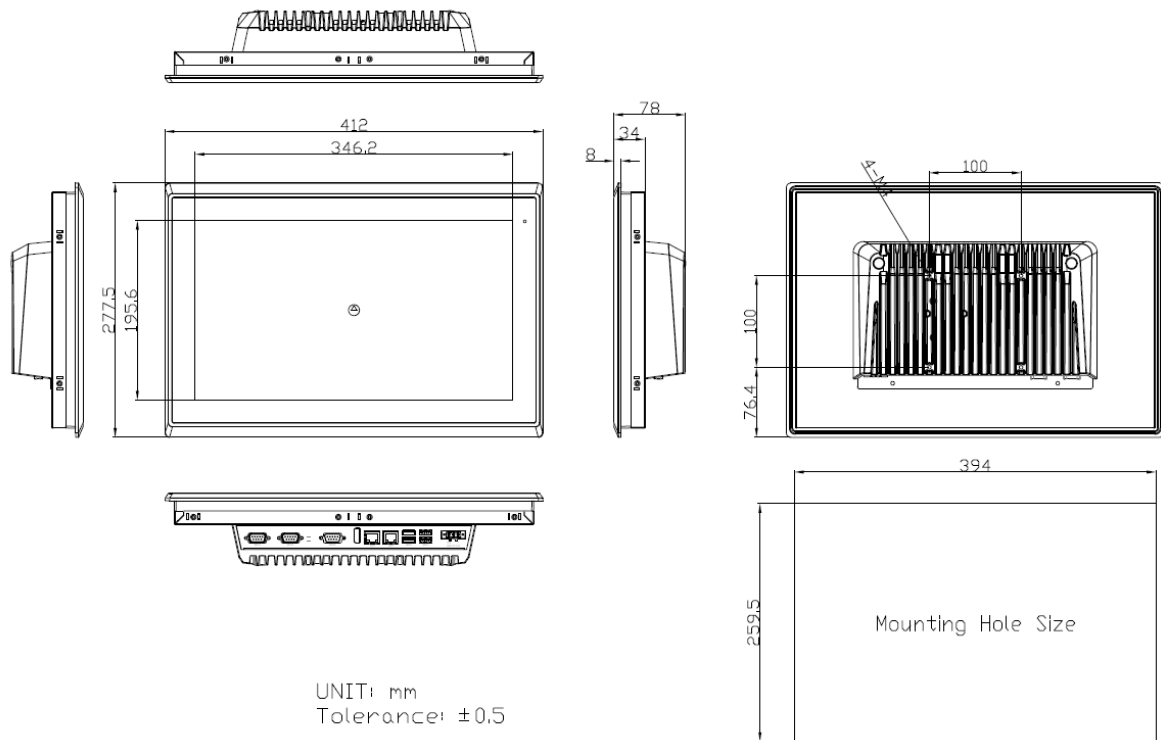

Figure 5 Dimensions of ARCHMI-S-916DP/R(H)

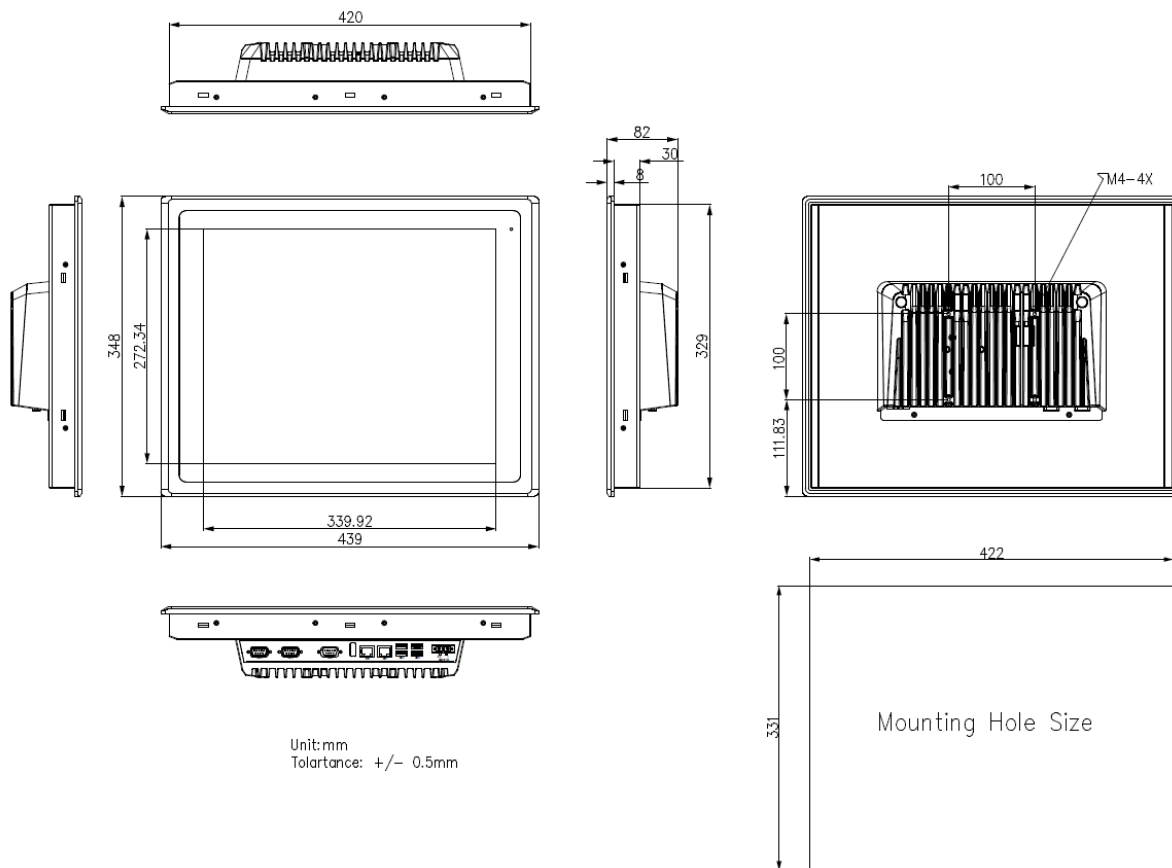

Figure 6 Dimensions of ARCHMI-S-917DP/R(H)

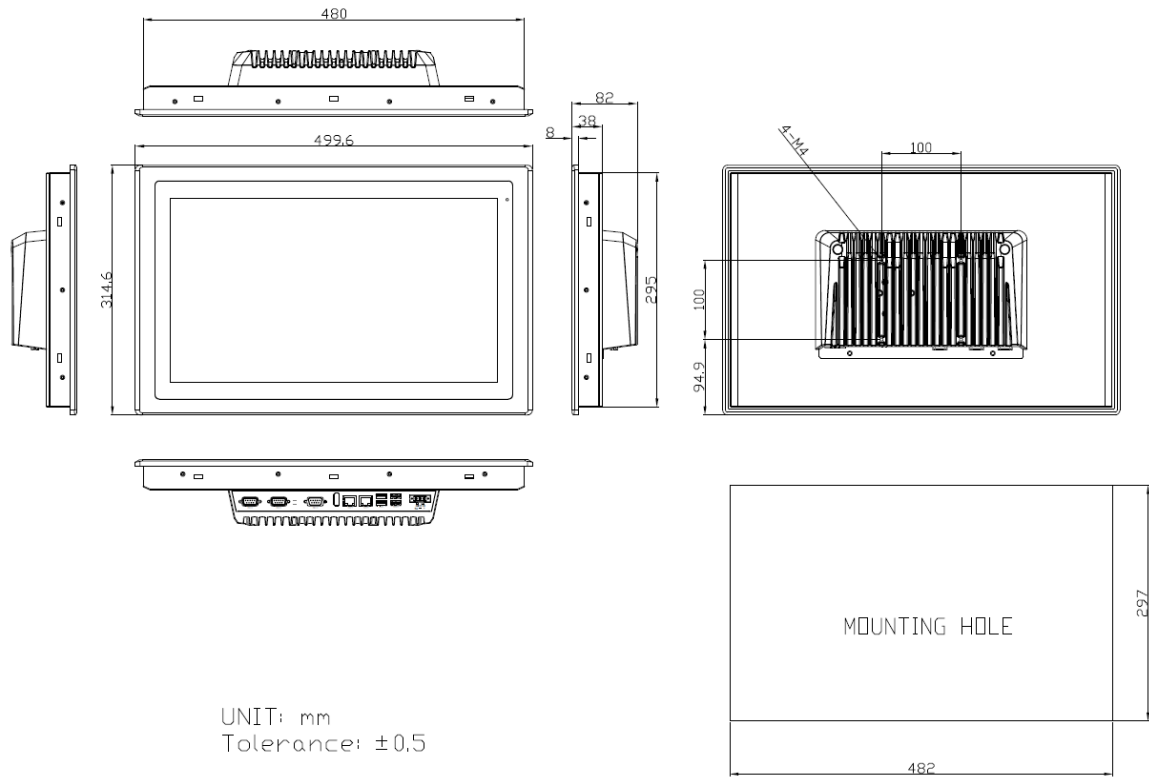

Figure 7 Dimensions of ARCHMI-S-918D P/R(H)

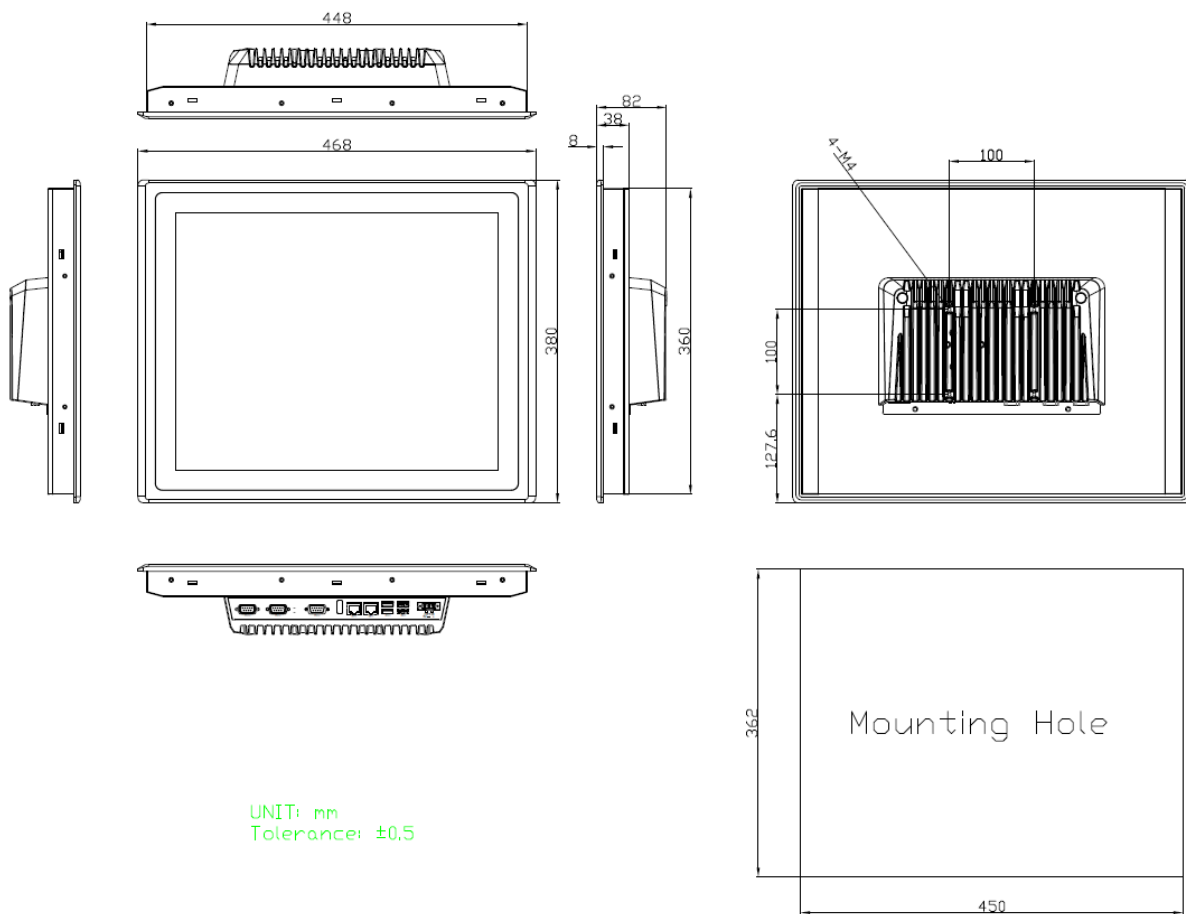

Figure 8 Dimensions of ARCHMI-S-919D P/R(H)

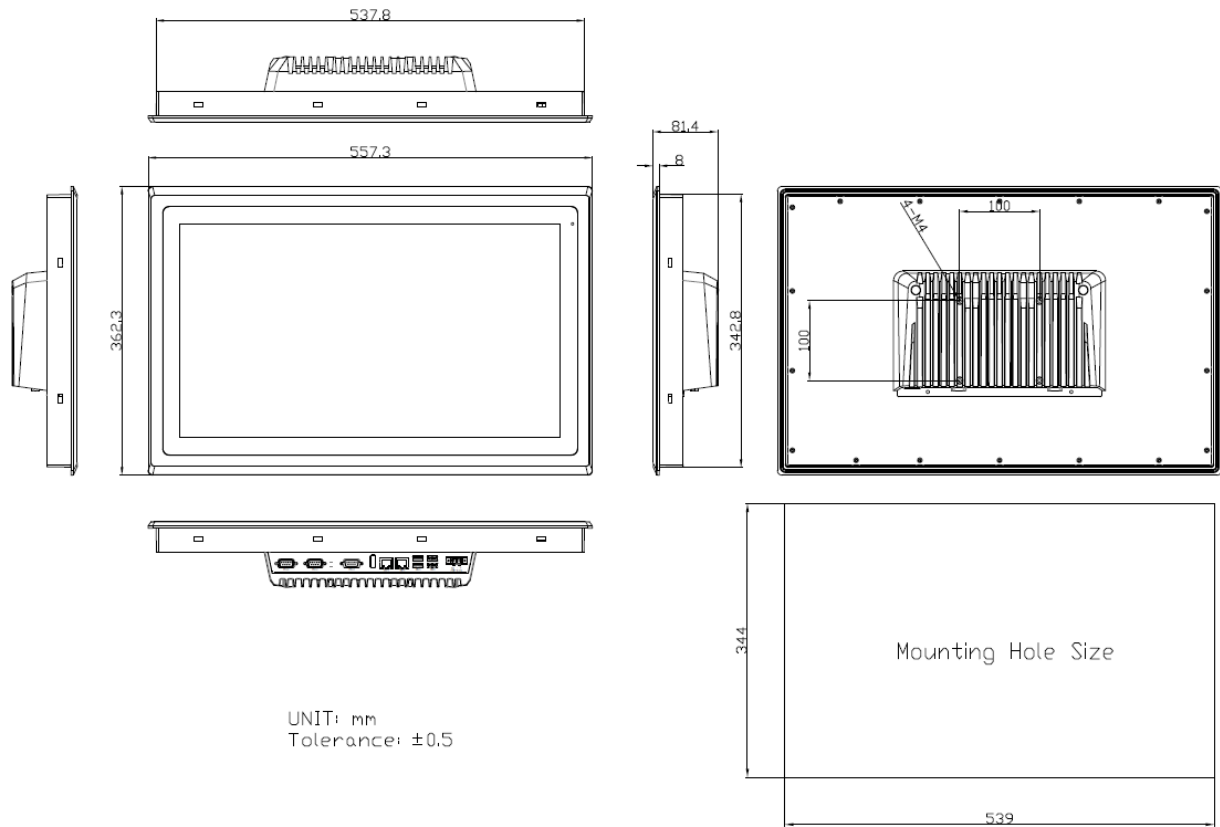

Figure 9 Dimensions of ARCHMI-S-921DP/R(H)

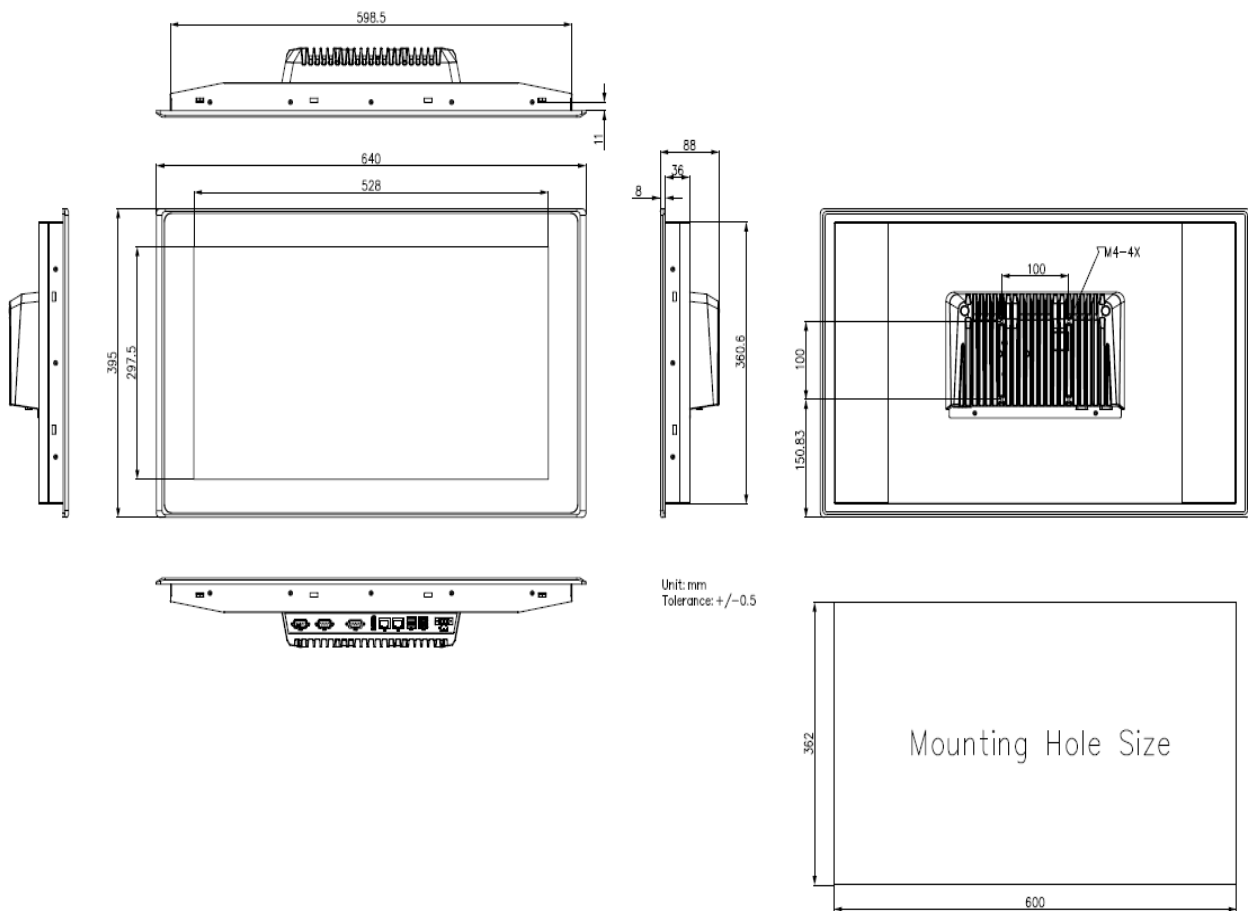

Figure 10 Dimensions of ARCHMI-S-924DP(H)

## 1.7 Brief Description of ARCHMI-S-9XXB Series

APLEX's ARCHMI-S-9XXD series products are a newly launched product line, ranging in size from 10.1" to 23.8". They feature a fanless, high-performance, and compact design, making them ideal for use as HMIs and control panels in smart production lines and self-service kiosks. With a protective aluminum enclosure, a full-plane resistive touchscreen or projected capacitive multi-touchscreen technology, and a wide-range power input from 9 to 36Vdc, the ARCHMI-S-9XXD series panel PCs can also be integrated with a variety of optional peripherals and accessories to meet specific application requirements.

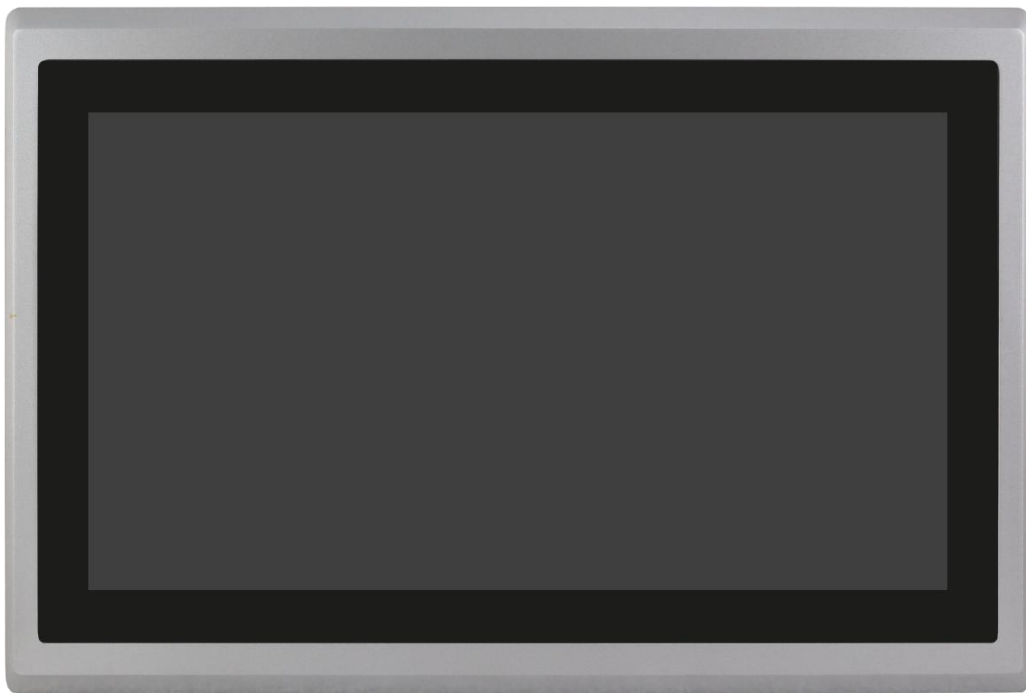

Figure 11 Front View of ARCHMI-S-916D



Figure 12 Rear View of ARCMHI-S-916D

## 1.8 Installation of Memory and Storage

Step 1 : Remove screws from the bottom side of back chassis.

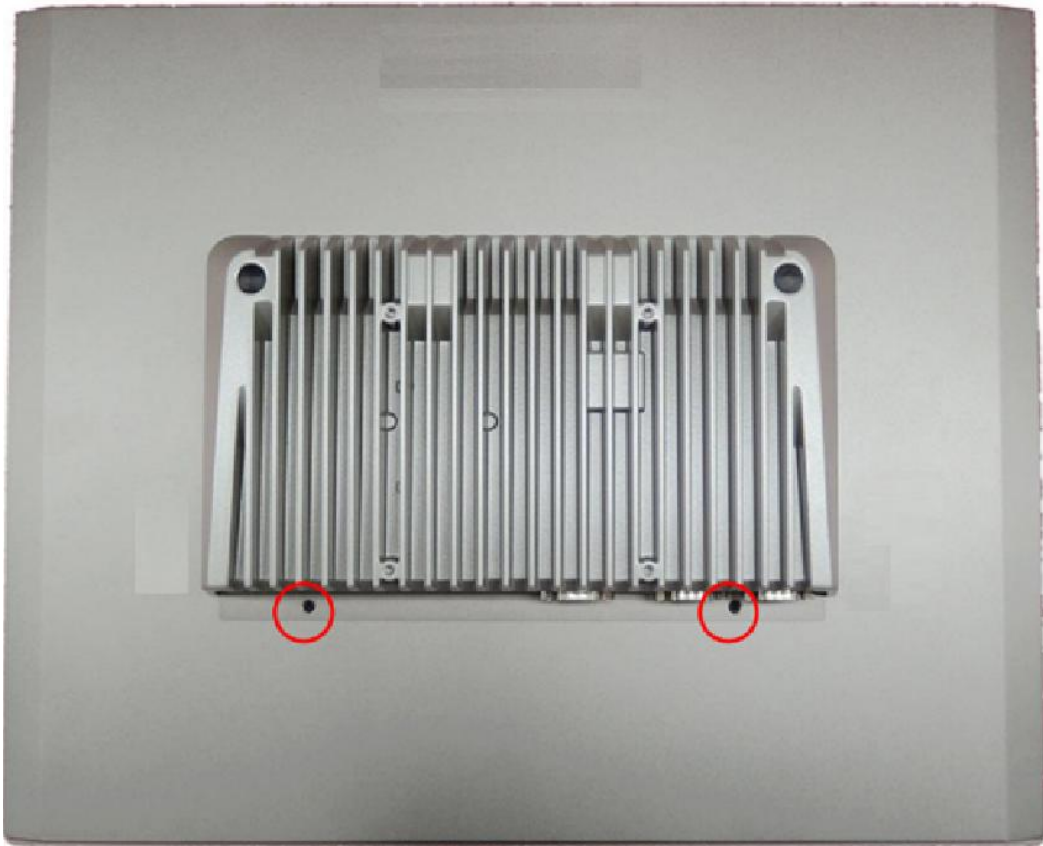

Step 2 : Push down back chassis from the system

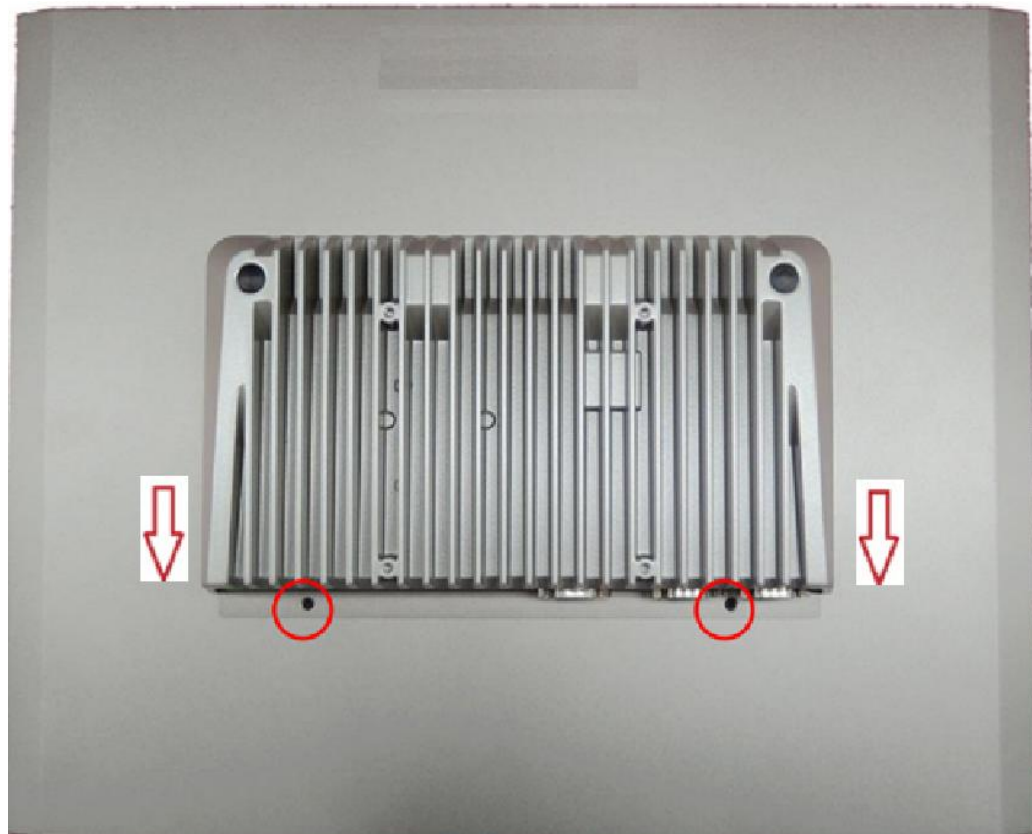

Step 3: Install memory module on the motherboard.  
Install M.2 M-Key 2280 for storage device (PCIe Type signal) on motherboard.

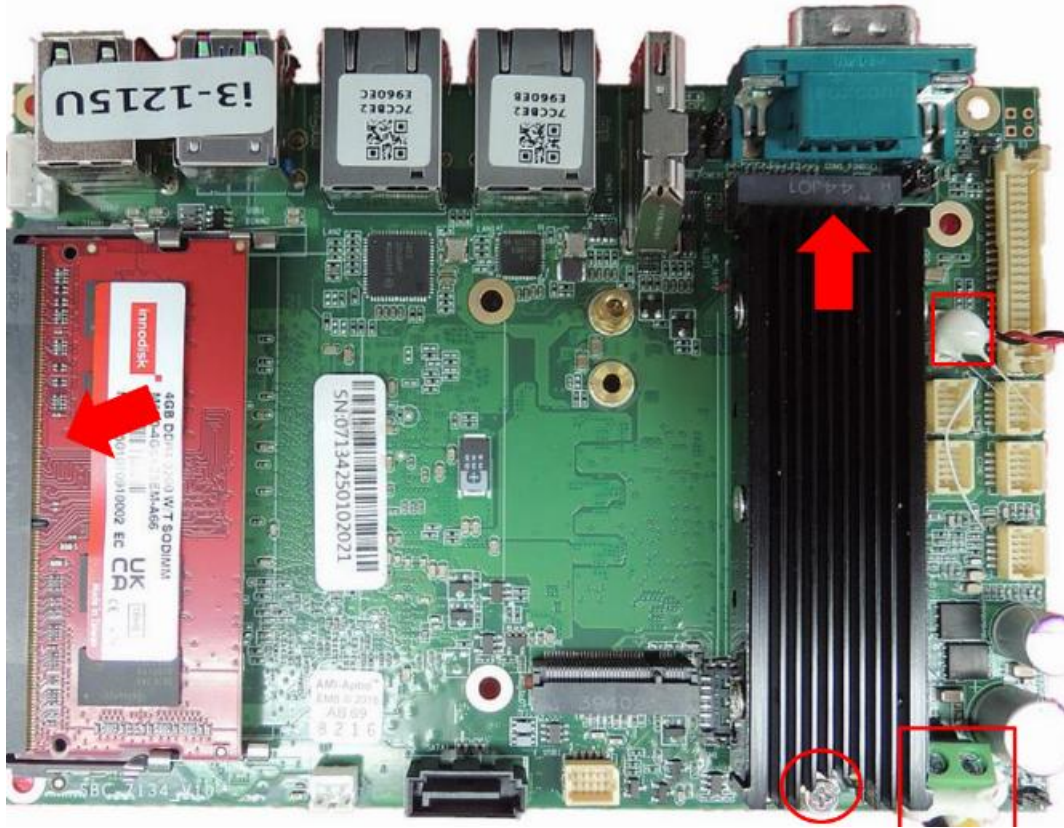

Step 4 : Push the back cover latch into the back cover sliding rail.

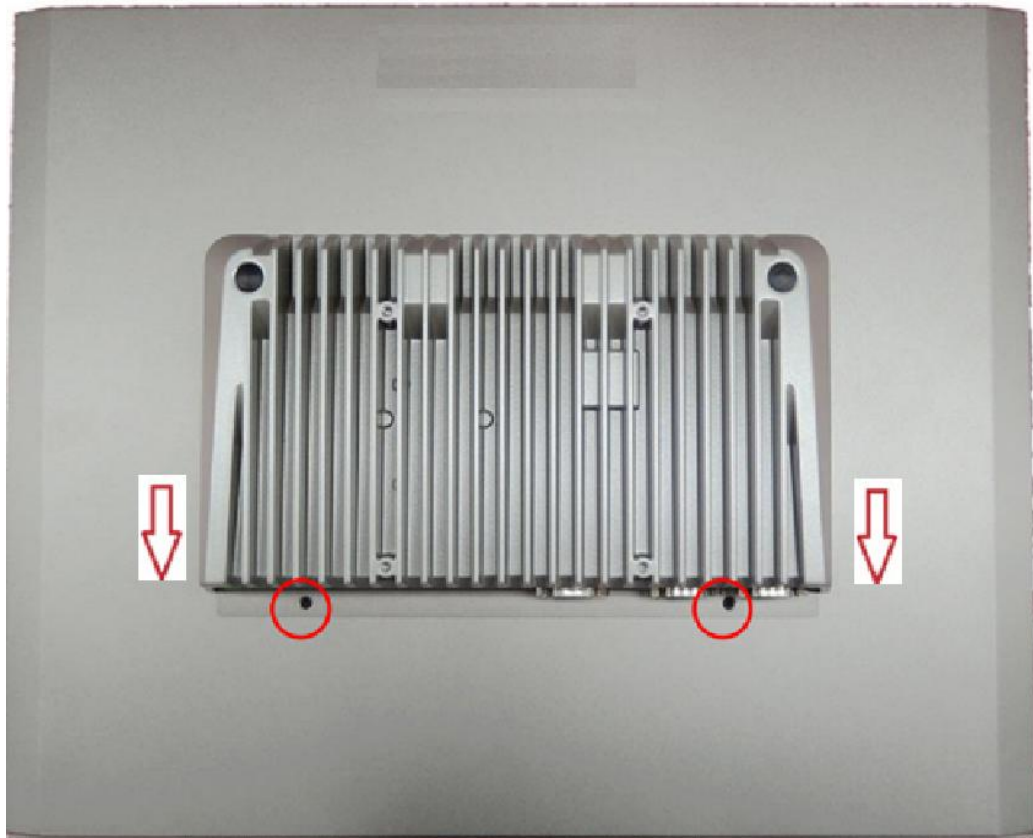

Step 5 : Tighten the screws.

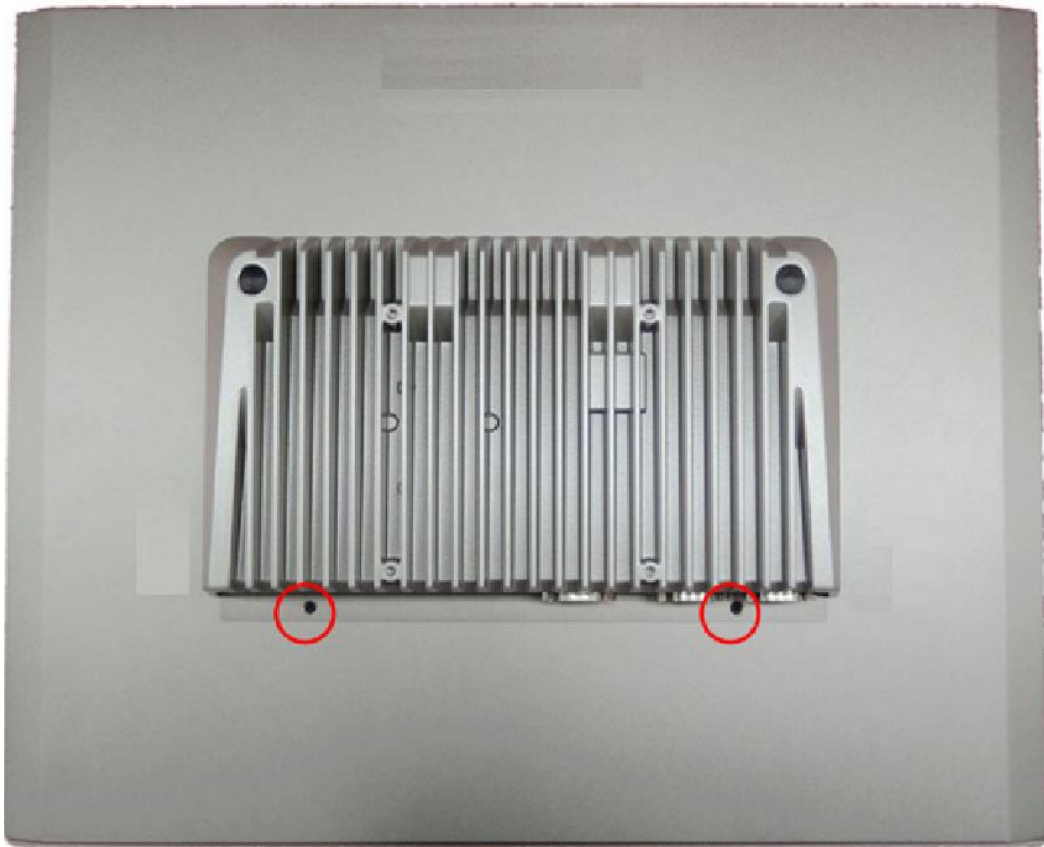

## 1.9 VESA Mounting

The ARCHMI-S-9XXD series support VESA 100 mount.

VESA 100, 4-M4 screw x 4 PCs

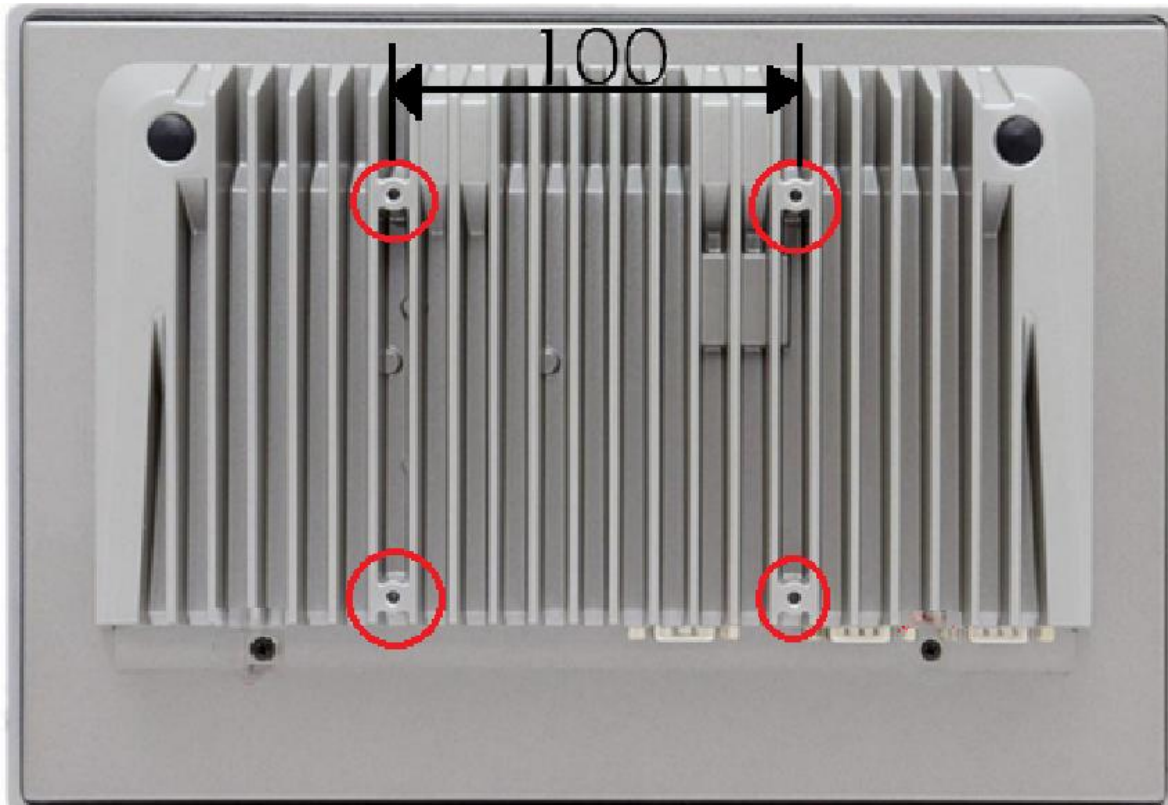

Figure 13 ARCHMI-S-9XXD VESA Mounting

## 1.10 Panel Mounting

There are mounting holes located along the four sides of the HMI. Position the ARCHMI-S panel pc against the panel mount and insert the mounting kit from the four sides and tighten them with screws.

Description	Qty	Unit
Panel mounting kit for 10.1" , 12.1" and 12.1"W	8	PCS
Panel mounting kit for 15" , 15.6" , 17" , 18.5" and 19"	10	PCS
Panel mounting kit for 21.5" , 23.8"	12	PCS

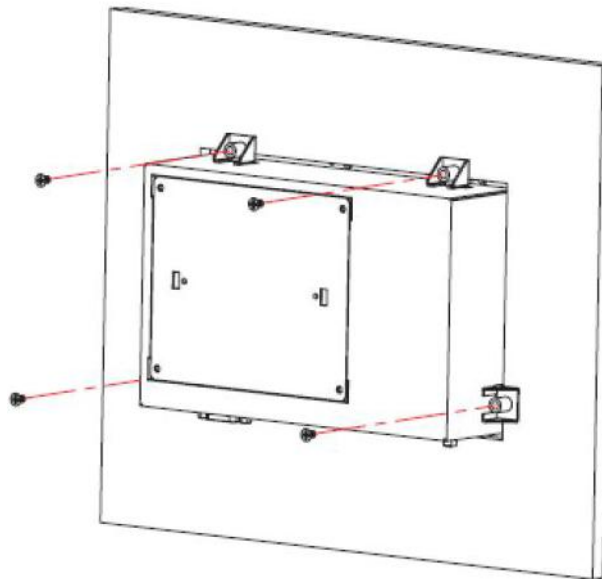

Figure 14 ARCHMI-S-9XXD PANEL Mounting

## 1.11 SSD heatsink kit installation guide

M.2 2280 HEAT SINK Dimension: 76 x 24 x 6.3mm

M.2 Module: The SSD module we test is Transcends TSXXXGMTE672A Series

Notice:

It is recommended to install an SSD heatsink to prevent the M.2 SSD from overheating during high-speed operations, which could lead to reduced performance or instability.

Step 1 :

Disassemble the SSD heatsink kit, then apply the thermal pad to both the top and bottom sides of the SSD. Secure the SSD to the thermal kit and tighten the screws.

### Mounting M.2 SSD

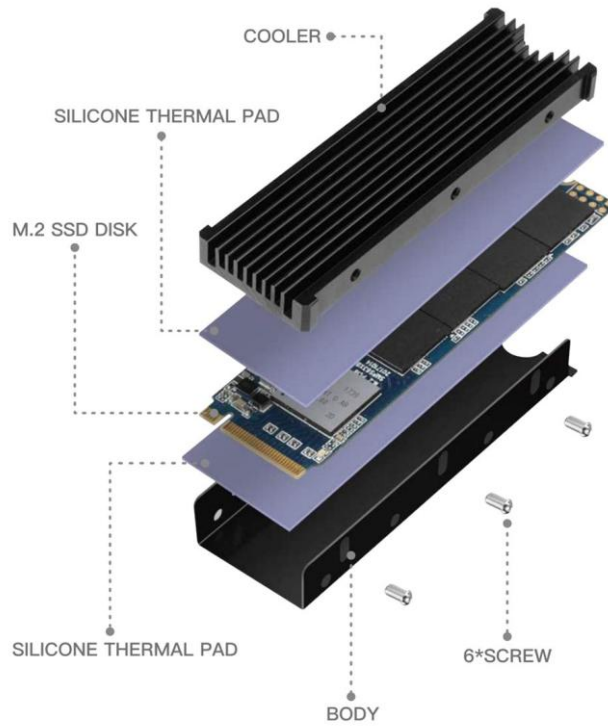

Step 2 :

Install the SSD with the thermal kit into the M.2 2280 slot on the motherboard.



SBC-7134 is a 3.5" industrial motherboard developed on the basis of Intel Alder Lake, which provides abundant peripheral interfaces to meet the needs of different customers.

## 2.1 Motherboard Specifications

Specifications	
<b>Board Size</b>	146mm x 101.6mm, 3.5"
<b>CPU Support</b>	Intel Core i3-1215U 2P/4E, P-core: 4.4GHz, E-core: 3.3GHz, 15W TDP Intel Core i5-1235U 2P/8E, P-core: 4.4GHz, E-core: 3.3GHz, 15W TDP Intel Core i7-1255U 2P/8E, P-core: 4.7GHz, E-core: 3.3GHz, 15W TDP Intel Core i3-1315UE 2P/4E, P-core: 4.5GHz, E-core: 3.3GHz, 15W TDP Intel Core i5-1335UE 2P/8E, P-core: 4.5GHz, E-core: 3.3GHz, 15W TDP
<b>Chipset</b>	SOC
<b>Memory Support</b>	1x SO-DIMM (260pins) DDR5-4800 MT/s, up to 48GB
<b>Graphics</b>	Integrated Intel UHD Graphics
<b>Display Mode</b>	1 x HDMI1.4b via HDMI Port 1 x LVDS (18/24-bit dual LVDS)
<b>Support Resolution</b>	HDMI: support up to 3840x2160@60Hz LVDS: support up to 1920x1200@60Hz
<b>Super I/O</b>	ITE IT8786E-I/HX
<b>BIOS</b>	AMI/UEFI BIOS
<b>Storage</b>	1 x SATAIII via 7pin SATA connector 1 x M.2 M-Key (2280) for Storage (PCIe signal)
<b>Ethernet</b>	1 x 10/100/1000M GbE LAN via intel® I210-AT controller (PXE/WOL) 1 x 10/100/1000M GbE LAN via intel® I219-LM controller (PXE/WOL)
<b>USB</b>	2 x USB3.2 gen1/ 2x USB2.0 Type-A stack ports (USB1) 2 x USB2.0, Type-A stack ports (USB2) 4 x USB2.0 via header
<b>Serial</b>	1 x RS-232(default)/422/485 select via BIOS, pin9 RI (default)/5V/12V select via jumper, DB9 (COM1) 1 x RS-232(default)/422/485 select via BIOS, wafer header (COM2) 4 x 3W RS232 via wafer header (COM3/COM4/COM5/COM6)
<b>GPIO</b>	8xGPIO (4xDI,4xDO) w/3.3V, via wafer header
<b>SMBus</b>	1x SMBus /I2C via wafer header
<b>Audio</b>	Support Line-in, Line-out, MIC by pin header

<b>Expansion Slots</b>	1 x M.2 B-Key(PCIex1, USB3.0, USB2.0),3042/3052 for 4G/5G module with Nano SIM slot (SIM1) 1 x M.2 E-Key(PCIex1,USB2.0),2230 for WIFI/BT module
<b>Front Panel</b>	1 x power button, 1 x reset button, power LED, HDD LED via wafer header
<b>LED Indicator</b>	1 x Power LED, 1 x HDD LED via stacked LED (By BOM Change)
<b>Watchdog Timer</b>	Software programmable 1–255 level
<b>TPM</b>	Support Intel PTT TPM2.0 Onboard Infineon_SLM9670 IC
<b>Battery</b>	Support 3V RTC Li-battery via 2pin wafer (VBAT1)
<b>Power Management</b>	Wide range DC 9~36V±10% power input via 2pin terminal block
<b>Temperature</b>	Operating: -30°C to 70°C Storage: -40°C to 85°C
<b>Humidity</b>	10% - 90%, non-condensing, operating
<b>Certifications</b>	Compliance CE/FCC class A UL, RoHS2.0

## 2.2 Board Dimensions

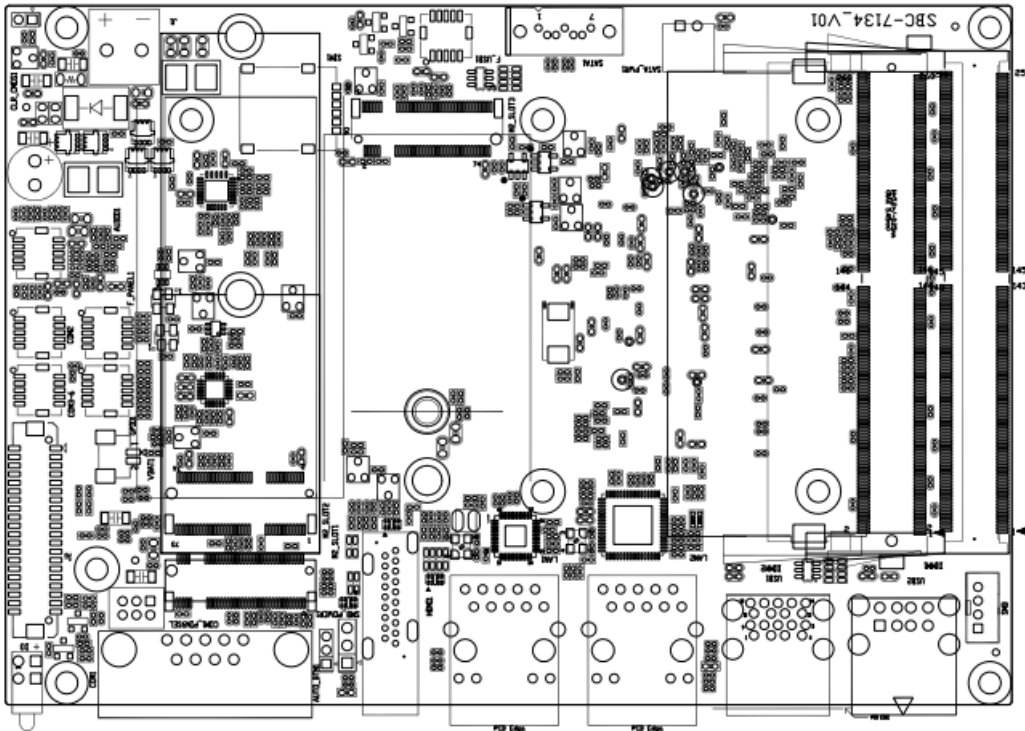

Dimensions: 146 x 101.6 (units :mm)

## 2.3 Jumpers and Connectors Location

Board Top

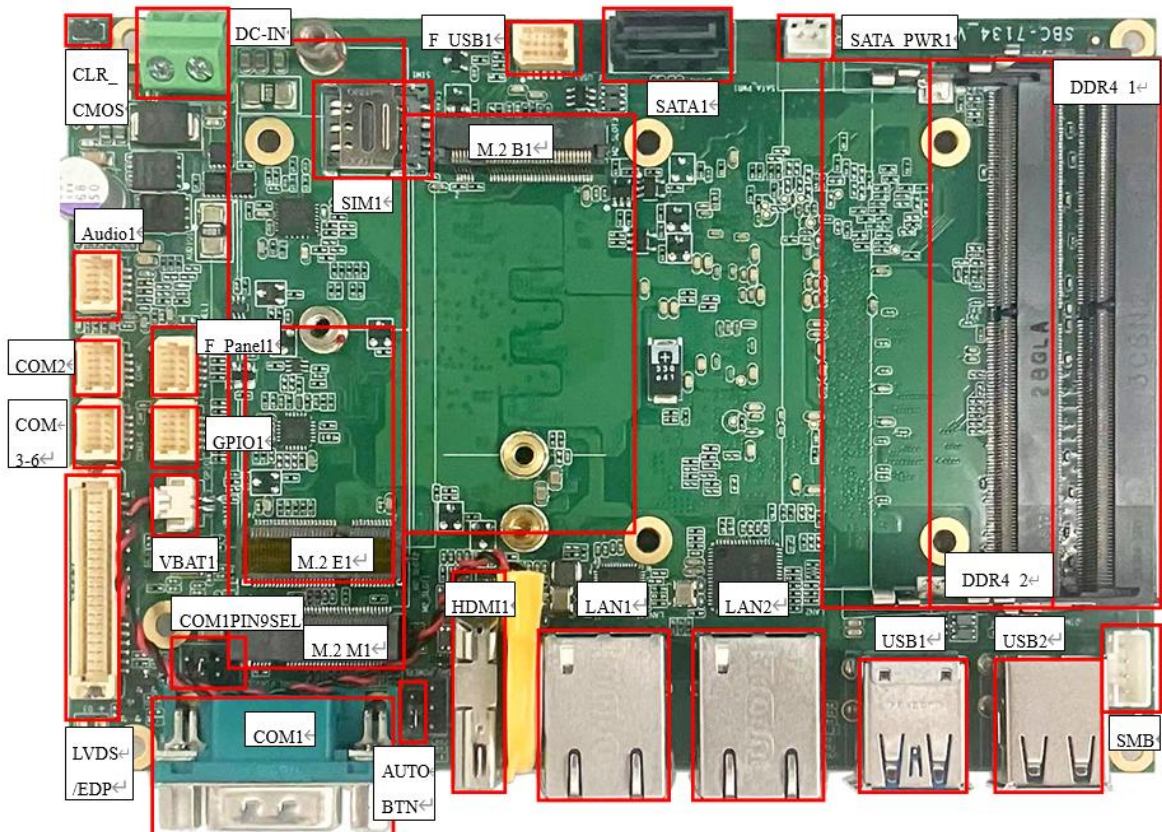



## 2.4 Jumpers Setting and Connectors

### 1. CPU1:

(FCBGA1744) Onboard Intel Alder Lake SoC

Model	SoC				
	Number	PBF	Cores/ Threads	TDP	Remarks
SBC-7134-I3 1215U	1215U	Up to 4.4GHz(P-Core) 3.3GHz(E-Core)	2C+4A / 8	15W-55W	Default
SBC-7134-I5 1235U	1235U	Up to 4.4GHz(P-Core) 3.3GHz(E-Core)	2C+8A / 12	15W-55W	Option
SBC-7134-I7 1255U	1255U	Up to 4.7GHz(P-Core) 3.3GHz(E-Core)	2C+8A / 12	15W-55W	Option
SBC-7134-I3 1315UE	1315UE	Up to 4.5GHz(P-Core) 3.3GHz(E-Core)	2C+4A / 8	15W-55W	Option
SBC-7134-I5 1355UE	1355UE	Up to 4.5GHz(P-Core) 3.3GHz(E-Core)	2C+8A / 12	15W-55W	Option

### 2. DDR5:

(SO-DIMM 260Pin slot) DDR4 memory socket, the socket is located at the top of the board and supports 260Pin 1.2V DDR5 SO-DIMM memory module up to 48GB.

Max Memory Size (dependent on memory type).

### 3. VBAT1:

(1.25mm Pitch 1x2 wafer Pin Header) 3.0V Li battery is embedded to provide power for CMOS.

Pin#	Signal Name
Pin1	VCC_RTC
Pin2	GND

### 4. CLR\_CMOS1:

CMOS clear switch, CMOS clear operation will permanently reset old BIOS settings to factory defaults.



#### Procedures of CMOS clear:

- Turn off the system and unplug the power cord from the power outlet.
- To clear the CMOS settings, close CLR\_CMOS1 for 1 second
- Power on the system again.
- When entering the POST screen, press the <DEL> key to enter CMOS Setup Utility to load optimal defaults.
- After the above operations, save changes and exit BIOS Setup.

### 5. CPU\_FAN1:

(1.25mm Pitch 1x2 wafer Pin Header) Fan connector, cooling fans can be connected directly for use.

Pin#	Signal Name
1	GND
2	VCC(5V_S0)



Note:

Output power of cooling fan must be limited under 3W.

### 6. DC\_IN1:

(5.08mm Pitch 1x2 Pin Connector) DC9~36V System power input connector.

Pin#	Power Input
Pin1	DC_IN+ (DC+9V~36V)
Pin2	DC_IN- (Ground)

### 7. SMB:

(2.00mm Pitch 1x4 Pin Header) For SMBUS interface Device.

Pin#	Signals
1	GND
2	Data
3	Clock
4	Vcc 3.3V

### 8. LVDS/EDP:

(1.25mm Pitch 2x20 Connector, DF13-40P) Support 18/24-bit LVDS interface LCM with USB2.0 signal for touch screen.

Function	Signal Name	Pin#	Signal Name	Function	
DC12V	12V_S0	1	2	12V_S0	DC12V
LVDS Signals	BKLT_PWM_OUT	3	4	BKLT_EN	LVDS /eDP Signals
	GND	5	6	GND	
	LVDS_VDD5	7	8	LVDS_VDD5	
	LVDS_VDD3.3	9	10	LVDS_VDD3.3	
	GND	11	12	GND	

	LA_D0-/EDP D0-	13	14	LA_D0+/EDP D0+	
	LA_D1-/EDP D1-	15	16	LA_D1+/EDP D1+	
	LA_D2-/EDP D2-	17	18	LA_D2+/EDP D2+	
	LA_D3-/EDP D3-	19	20	LA_D3+/EDP D3+	
	LA_CLK-/EDP AUX-	21	22	LA_CLK+/EDP AUX+	
	LB_D0-	23	24	LB_D0+	
	LB_D1-	25	26	LB_D1+	
	LB_D2-	27	28	LB_D2+	
	LB_D3-	29	30	LB_D3+	
	LB_CLK-	31	32	LB_CLK+	
USB3	GND	33	34	GND	USB3
	USB2 9D-	35	36	USB2 9D+	
SMBus	SM bus DAT	37	38	5V_S5	Power LED
	SM bus CLK	39	40	Power LED+	

### 9. HDMI1:

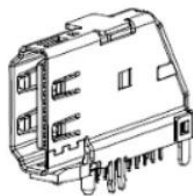

(Vertical HDMI Connector) HDMI Interface connector.  
HDMI 1.4, Support resolution up to 3840x2160@60Hz.

### 10. LAN1:

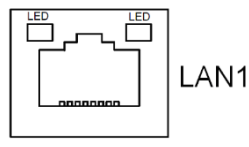

(RJ45 Connector) Provide 100/1000GbE LAN via Intel® I219-V.

Status	Description
Green	100Mbps
Yellow	1Gbps

**11. LAN2:**

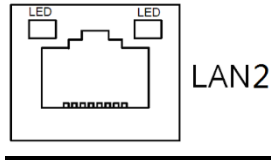

(RJ45 Connector) Provide 100/1000GbE LAN via Intel® I210-AT.

Status	Description
Green	100Mbps
Yellow	1Gbps

**12. F\_AUDIO1:**

(SHD 1.25mm 2x5pin header) Provide line-in/line-out/mic-in via onboard Realtek ALC897 codec.

Signal Name	Pin#	Pin#	Signal Name
LINE-OUT-R	1	2	LINE-OUT-L
GND	3	4	GND
MIC-IN-R	5	6	MIC-IN-L
GND	7	8	GND
LINE-IN-R	9	10	LINE-IN-L

**13. USB1 、USB2:**

(Double stack USB type-A) Rear USB3.2 connector, provides up to 2 USB3.2 gen1/USB2.0 ports, USB3.2 gen1 allows data transfers up to 5.0Gbps.

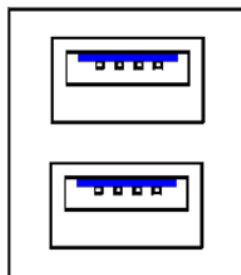

Each USB Type A Receptacle (2 Ports) Current limited value is 2A.

If the external USB device current exceeds 2.0A, please separate connectors into different Receptacle.

**14. F\_USB1:**

(SHD 1.25mm 2x5pin header) Provide 2xUSB2.0 signals.

Signal Name	Pin#	Pin#	Signal Name
5V_USB23	1	2	5V_USB23
USB2_N	3	4	USB3_N
USB2_P	5	6	USB3_P
GND	7	8	GND
GND	9	10	GND

**15. COM1:**

(DB9 connector) Provide serial RS232/422/485 via standard DB9 male connector. Default is set to RS232, RS422/485 can be selected via BIOS. Pin 9 RI/5V/12V select via COM1\_PIN9SEL.

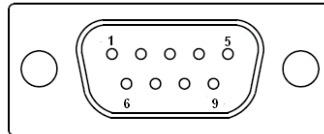

RS232 (Default):	
Pin#	Signal Name
1	DCD# (Data Carrier Detect)
2	RXD (Received Data)
3	TXD (Transmit Data)
4	DTR (Data Terminal Ready)
5	GND
6	DSR (Data Set Ready)
7	RTS (Request To Send)
8	CTS (Clear To Send)
9	JP1 select Setting (RI/5V/12V)
BIOS Setup : Serial Port 1 Configuration 【RS-232】	

RS422 (option):	
Pin#	Signal Name
1	422_TX-
2	422_TX+
3	422_RX+
4	422_RX-
5	GND
6	NC

7	NC
8	NC
9	NC
BIOS Setup : Serial Port 1 Configuration 【RS-422】	

RS485 (option):	
Pin#	Signal Name
1	485-
2	485+
3	NC
4	NC
5	GND
6	NC
7	NC
8	NC
9	NC
BIOS Setup : Serial Port 1 Configuration 【RS-485】	

**16. COM1\_PIN9SEL:**

(2.0mm Pitch 2x3 Pin Header) For COM1 pin9 signal setting.

JP1 Pin#	Function
Close 1-2	COM1 Pin9 = +12V
<b>Close 3-4</b>	<b>COM1 Pin9 RI (Ring Indicator, Default)</b>
Close 5-6	COM1 Pin9 = +5V

**17. COM2:**

(SHD 1.25mm 2x5pin header) Provide RS232 RS422/485, Default is set to RS232, RS422/485 can be selected via BIOS.

Signal Name	Pin#	Pin#	Signal Name
DCD	1	2	RXD
TXD	3	4	DTR
GND	5	6	DSR
RTS	7	8	CTS
RI	9	10	NC

**18. COM3-6:**

(SHD 1.25mm 2x5pin header) Provide 4x2wired RS232(COM3/4/5/6).

Signal Name	Pin#	Pin#	Signal Name
COM3_RX	1	2	COM3_TX
COM4_RX	1	2	COM4_TX
COM5_RX	1	2	COM5_TX
COM6_RX	1	2	COM6_TX
GND	9	10	GND

**19. GPIO1:**

(SHD 1.25mm 2x5pin header) Provide 8Xgpio with 3.3V VCC.

Signal Name	Pin#	Pin#	Signal Name
3.3V_GPIO	1	2	GND
GPIO0	3	4	GPIO1
GPIO2	5	6	GPIO3
GPIO4	7	8	GPIO5
GPIO6	9	10	GPIO7

**20. F\_Panel1:**

(SHD 1.25mm 2x5pin header) Provide power button/reset button/power LED/HDD LED.

Signal Name	Pin#	Pin#	Signal Name
HDD LED+	1	2	Power LED+
HDD LED-	3	4	Power LED-
Reset Button-	5	6	Power Button+
Reset Button+	7	8	Power Button-
NC	9	10	NC

**21. SIM1:**

(Nano-SIM Slot) Support Nano SIM card for M.2 B Key.

Pin#	Signal Name
1	SIMVCC
2	SIM_RST
3	SIM_CLK
4	GND

5	NC
6	SIM_DAT

**22. M2\_B1:**

(M.2 B-Key Socket) Support 3042/3052 4G/5G module with Nano SIM slot, and Support 2242 Nvme/NGFF interface SSD.

**23. M2\_M1:**

(M.2 M-Key Socket) Provide PCIe4, support M-key 2280 Nvme interface SSD.

**24. M2\_E1:**

(M.2 E-Key Socket) Provide USB2.0/PCIe1, support E-key 2230 Wi-Fi/BT expansion cards.

**25. SATA1:**

(SATA 7Pin) SATA connector provide SATA III signal for storages.

**26. SATA\_PWR1:**

(2.0mm Pitch 1x2 Wafer Pin Header) 5V power supply for SATA1 port device.

Pin#	Signal Name
1	5V_S0
2	GND



**Note:**

**Output current of the connector must not be above 1A.**

**27. AUTO\_BTN:**

The AUTO\_STN button allows you to select automatic power on after the motherboard is powered on.

state	function
Pin1-2 short circuit	AT Mode(Default, auto power ON)
Pin2-3 short circuit	ATX Mode(Manual Power ON)
*Note: Compatible with BIOS version 02	

## 3.1 Operations after POST Screen

After CMOS discharge or BIOS flashing operation. Press [Delete] key to enter CMOS Setup.



After optimizing and exiting CMOS Setup

## 3.2 BIOS SETUP UTILITY

Press [Delete] key to enter BIOS Setup utility during POST, and then a main menu containing system summary information will appear.

### 3.3 Main Settings

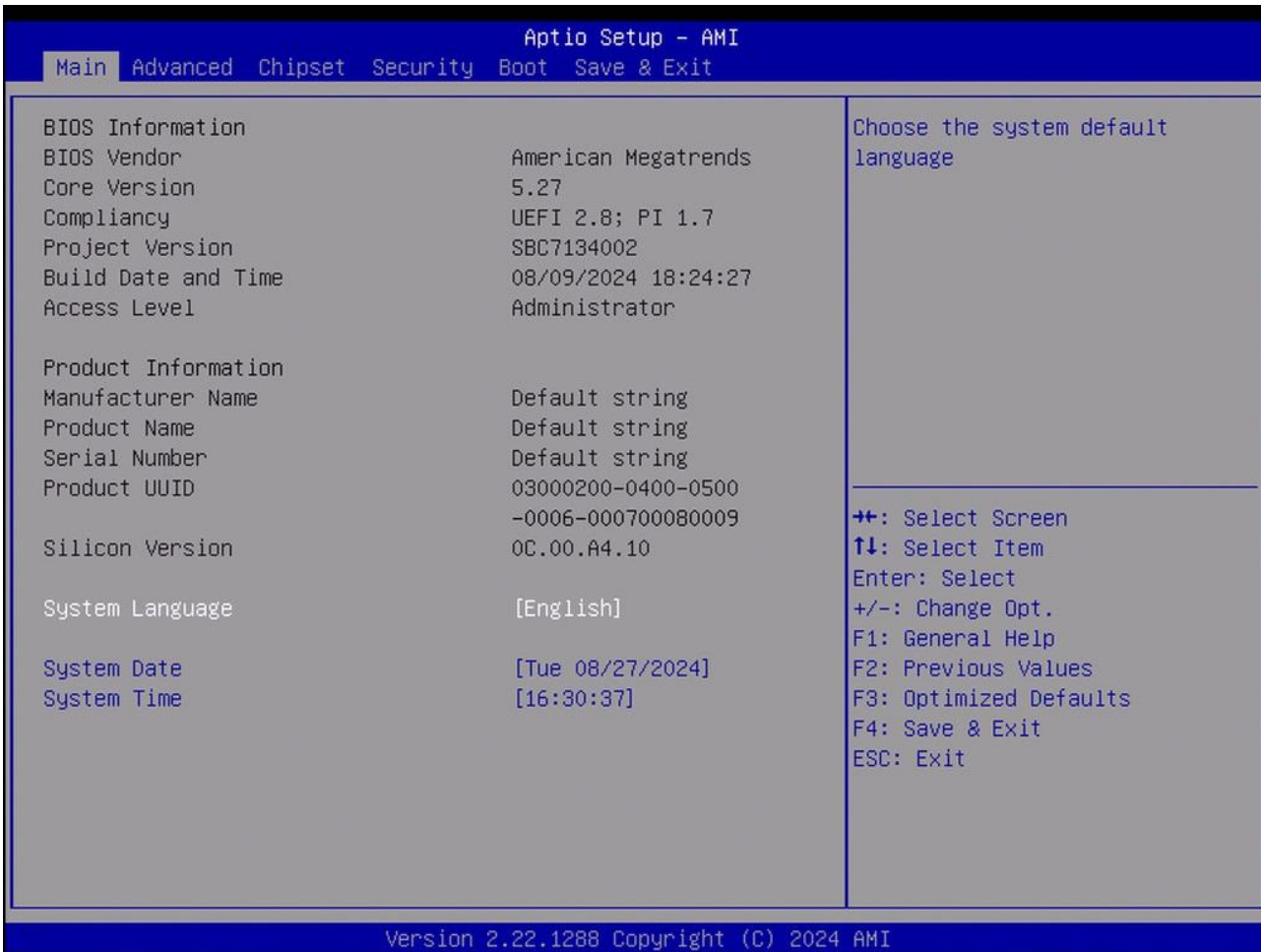

#### System Time:

Set the system time, the time format is:

Hour : 0 to 23

Minute : 0 to 59

Second : 0 to 59

#### System Date:

Set the system date, the date format is:

Day: Note that the 'Day' automatically changes when you set the date.

Month: 01 to 12

Date: 01 to 31

Year: 1998 to 2099

#### NOTE:

When all selectable items are not listed in the BIOS, it only has two options to "Enabled" or "Disabled".

### 3.4 Advanced Settings

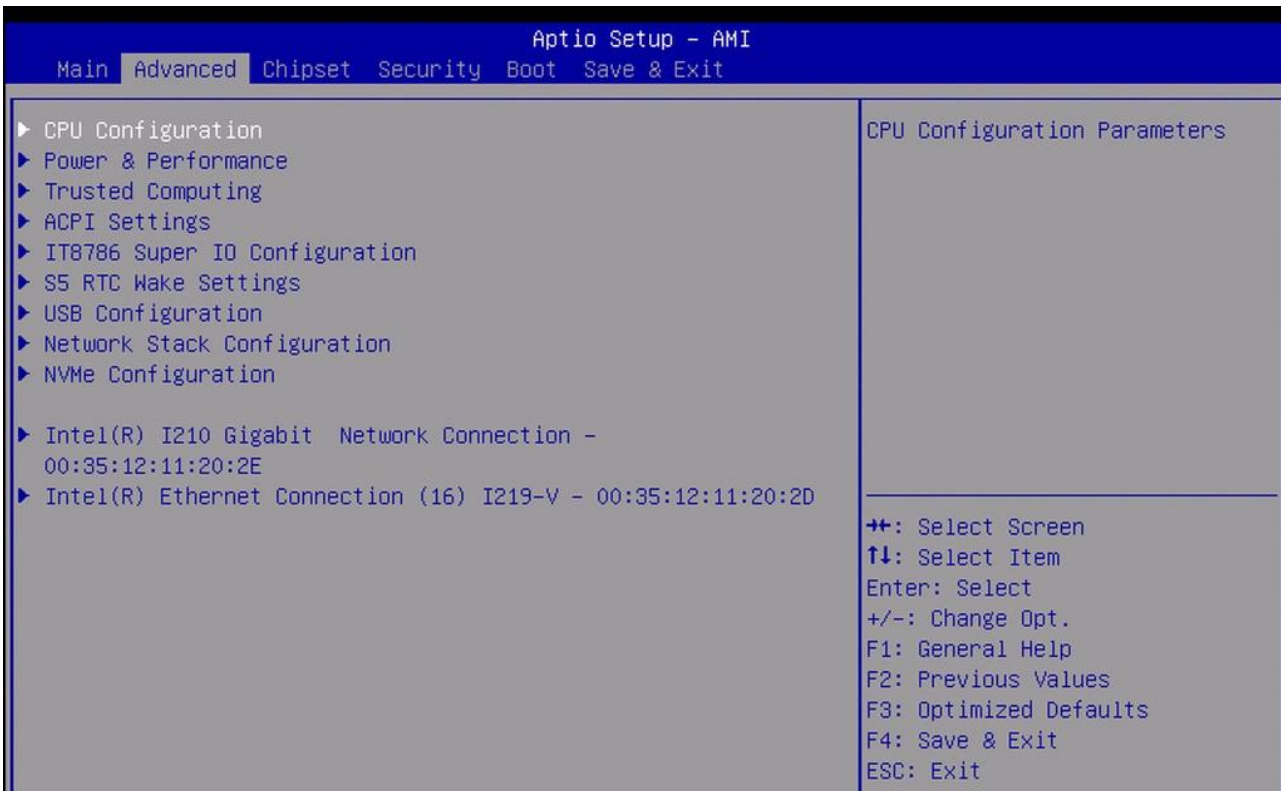

#### 3.4.1 CPU Configuration

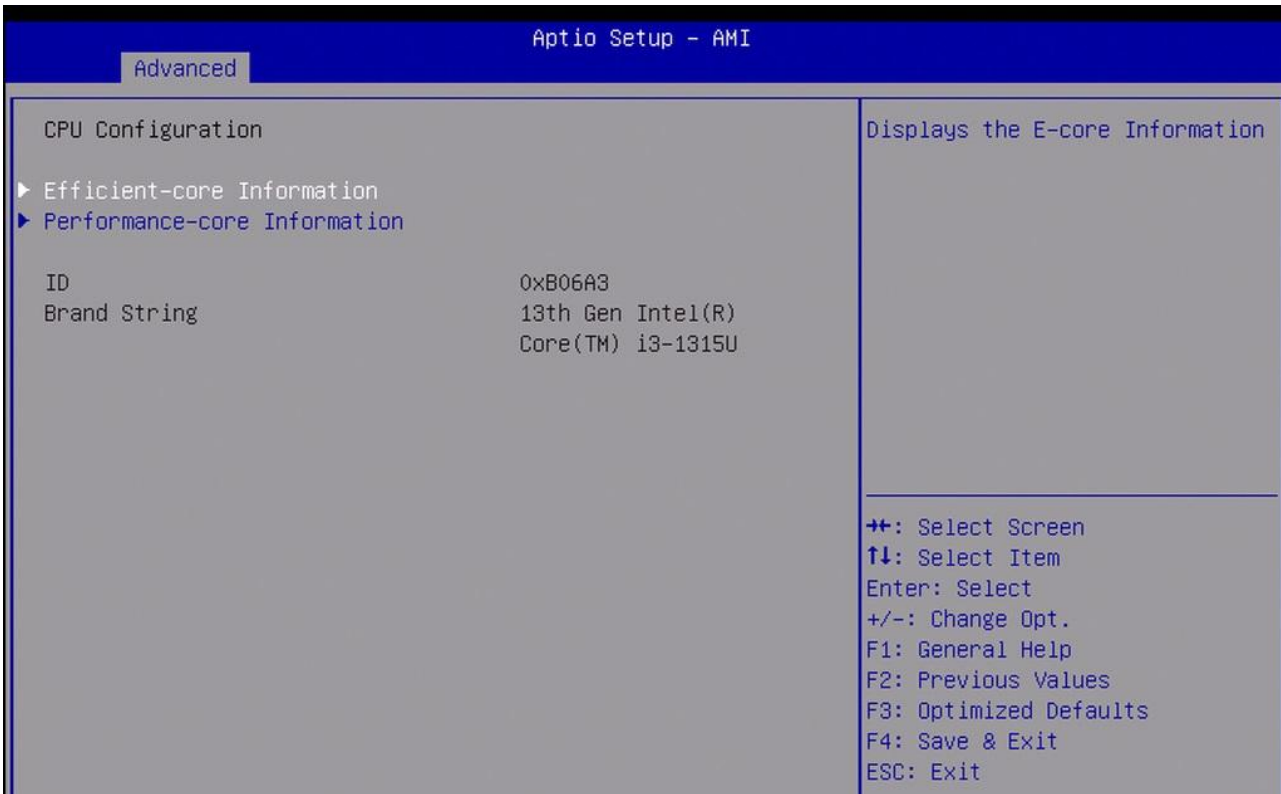

### 3.4.1.1 Efficient-core Information

The screenshot shows the 'Advanced' menu in the Aptio Setup - AMI utility. The 'Efficient-core Information' section displays the following cache specifications:

L1 Data Cache	32 KB x 4
L1 Instruction Cache	64 KB x 4
L2 Cache	2048 KB
L3 Cache	10 MB

Navigation instructions are listed at the bottom right:

- +/: Select Screen
- ↑↓: Select Item
- Enter: Select
- +/-: Change Opt.
- F1: General Help
- F2: Previous Values
- F3: Optimized Defaults
- F4: Save & Exit
- ESC: Exit

### 3.4.1.2 Performance-core Information

The screenshot shows the 'Advanced' menu in the Aptio Setup - AMI utility. The 'Performance-core Information' section displays the following cache specifications:

L1 Data Cache	48 KB x 2
L1 Instruction Cache	32 KB x 2
L2 Cache	1280 KB x 2
L3 Cache	10 MB

Navigation instructions are listed at the bottom right:

- +/: Select Screen
- ↑↓: Select Item
- Enter: Select
- +/-: Change Opt.
- F1: General Help
- F2: Previous Values
- F3: Optimized Defaults
- F4: Save & Exit
- ESC: Exit

### 3.4.2 Power & Performance



#### 3.4.2.1 CPU-Power Management Control

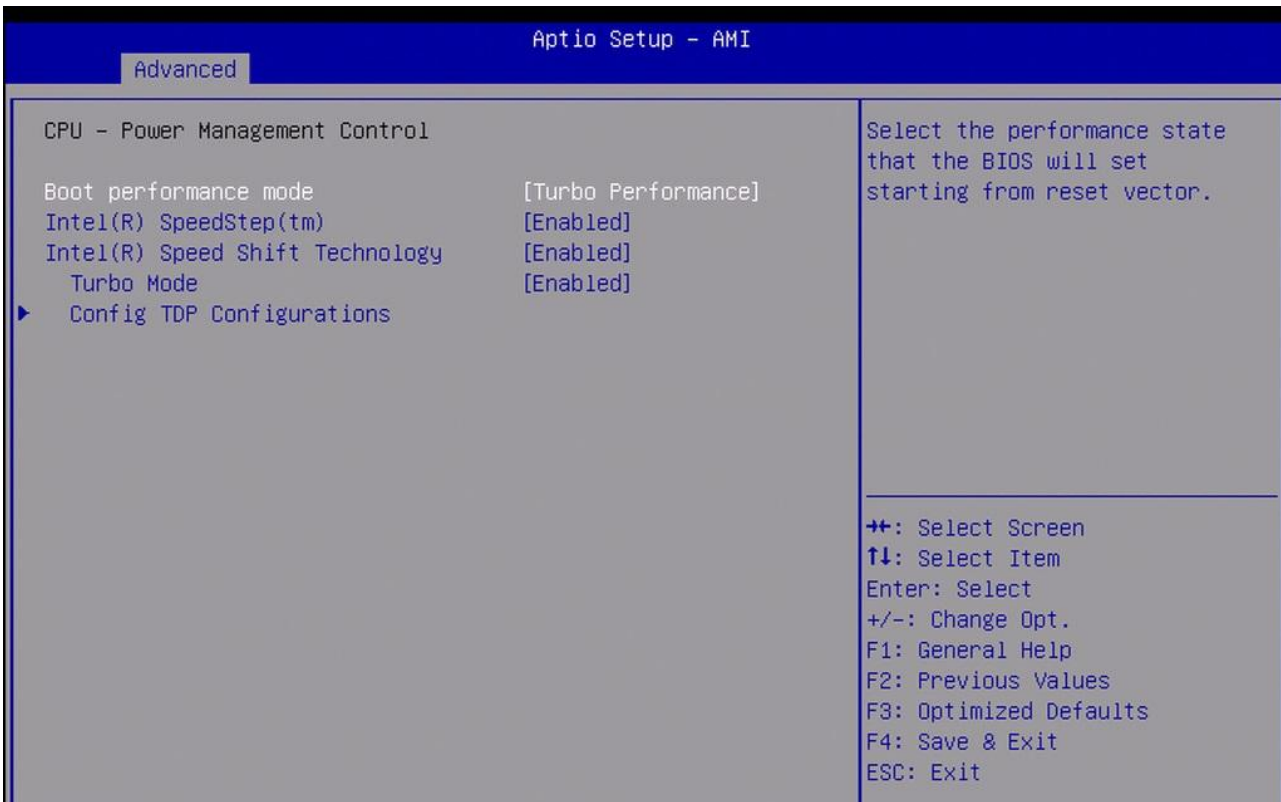

### 3.4.2.1.1 Boot performance mode

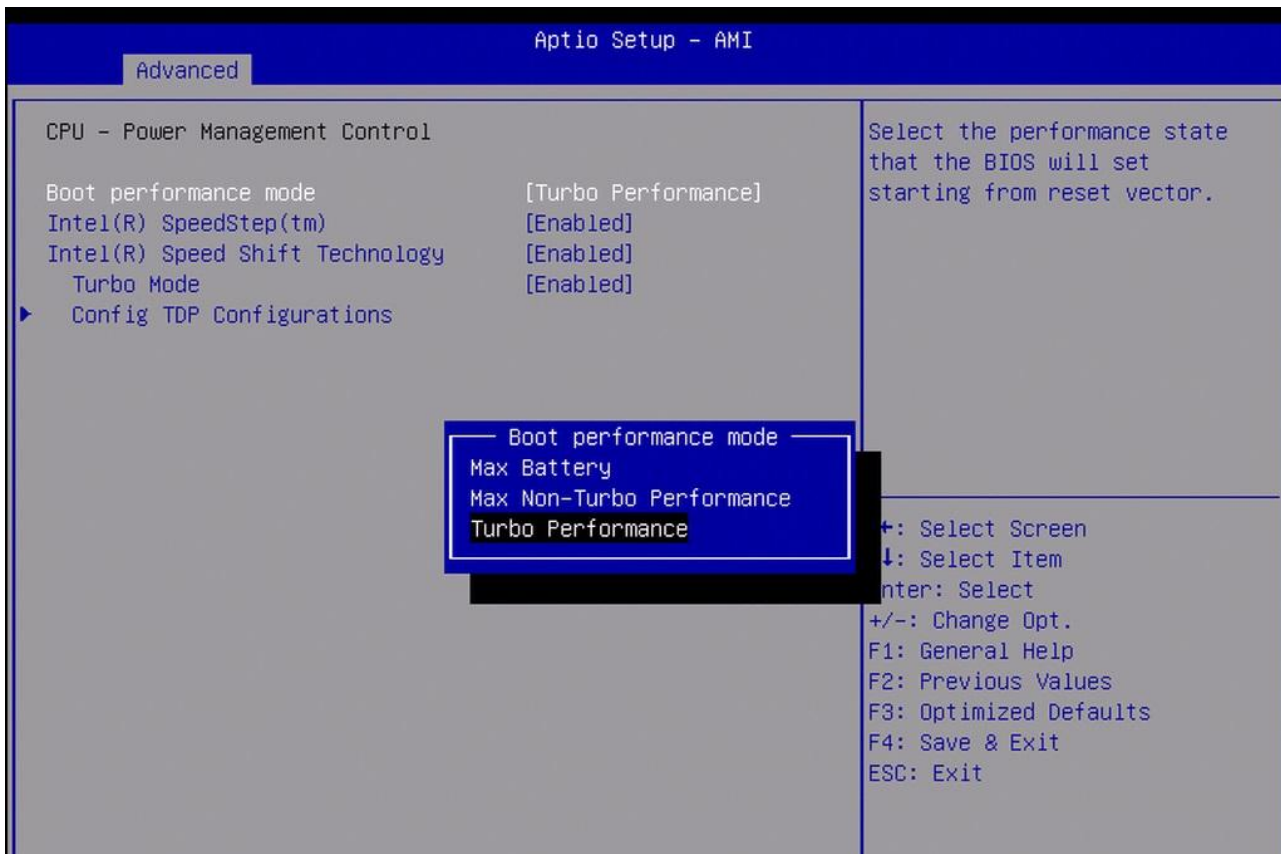

### 3.4.2.1.2 Config TDP Configurations

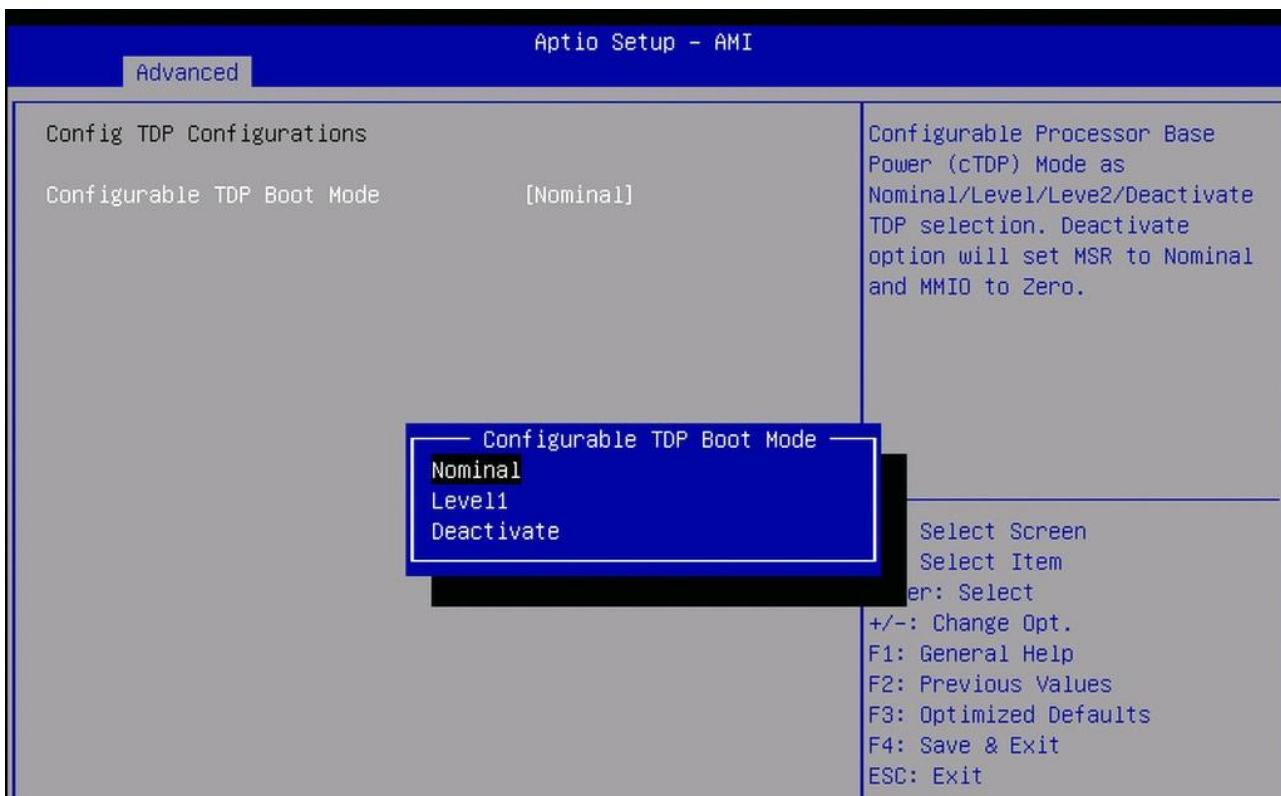

### 3.4.2.2 GT- Power Management Control

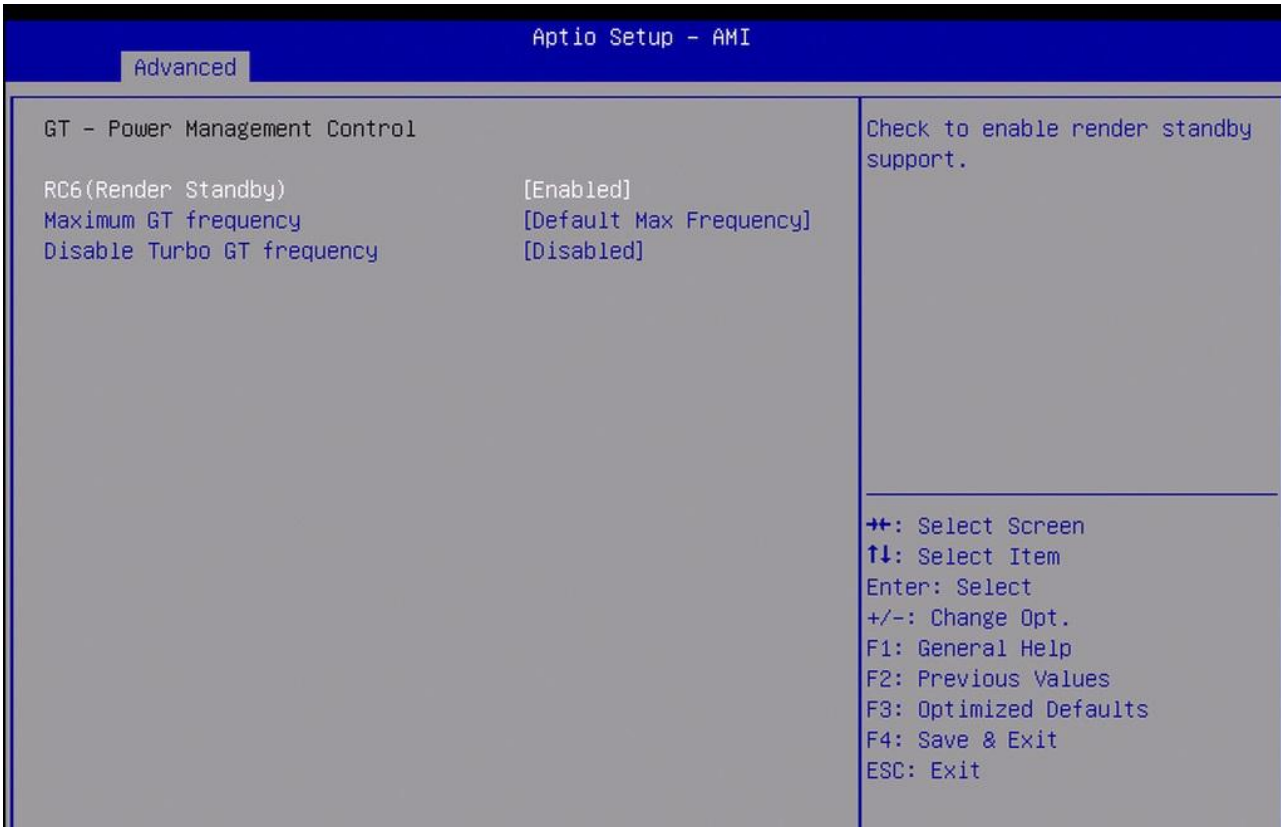

#### Maximum GT frequency

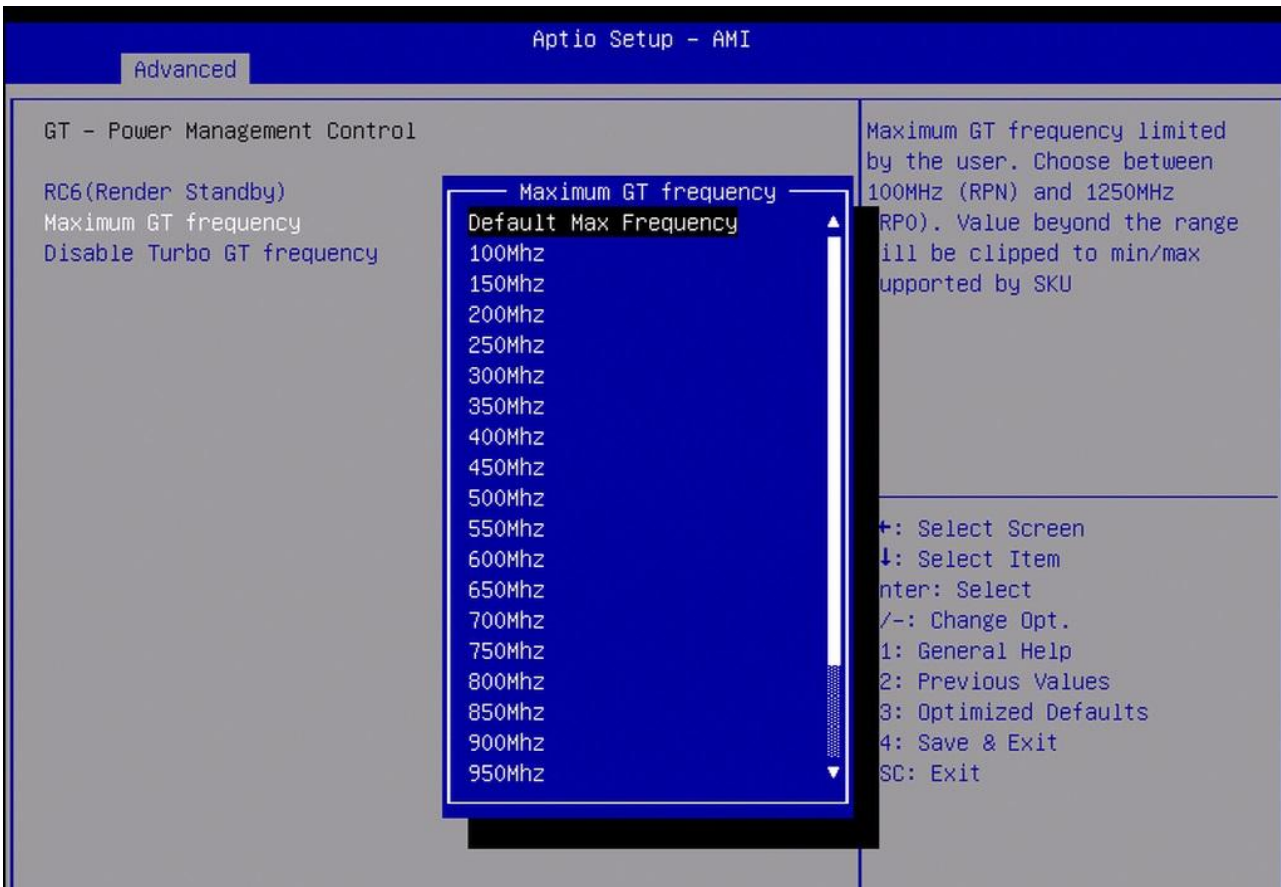

### 3.4.3 Trusted Computing

Aptio Setup - AMI

Advanced

TPM 2.0 Device Found		Enables or Disables BIOS support for security device. O.S. will not show Security Device. TCG EFI protocol and INT1A interface will not be available.
Firmware Version:	7.85	
Vendor:	IFX	
Security Device Support	[Enable]	
Active PCR banks	SHA256	
Available PCR banks	SHA256	
SHA256 PCR Bank	[Enabled]	
Pending operation	[None]	
Platform Hierarchy	[Enabled]	
Storage Hierarchy	[Enabled]	
Endorsement Hierarchy	[Enabled]	++: Select Screen ↑↓: Select Item Enter: Select +/-: Change Opt. F1: General Help F2: Previous Values F3: Optimized Defaults F4: Save & Exit ESC: Exit
Physical Presence Spec Version	[1.3]	
TPM 2.0 InterfaceType	[TIS]	
Device Select	[Auto]	

#### 3.4.3.1 Pending operation

Aptio Setup - AMI

Advanced

TPM 2.0 Device Found		Schedule an Operation for the Security Device. NOTE: Your Computer will reboot during restart in order to change State of Security Device.
Firmware Version:	7.85	
Vendor:	IFX	
Security Device Support	[Enable]	
Active PCR banks	SHA256	
Available PCR banks	SHA256	
SHA256 PCR Bank	[Enabled]	
Pending operation	Pending operation	
Platform Hierarchy	None	
Storage Hierarchy	TPM Clear	
Endorsement Hierarchy		++: Select Screen ↑↓: Select Item Enter: Select +/-: Change Opt. F1: General Help F2: Previous Values F3: Optimized Defaults F4: Save & Exit ESC: Exit
Physical Presence Spec Version		
TPM 2.0 InterfaceType	[TIS]	
Device Select	[Auto]	

### 3.4.3.2 Physical Presence Spec Version

The screenshot shows the 'Advanced' menu of the Aptio Setup - AMI. The 'Physical Presence Spec Version' option is highlighted, and a sub-menu is open showing '1.2' and '1.3' as available options. The '1.3' option is currently selected. The background menu items include TPM 2.0 Device Found, Security Device Support, SHA256 PCR Bank, Pending operation, Platform Hierarchy, Storage Hierarchy, Endorsement Hierarchy, Physical Presence Spec Version, TPM 2.0 InterfaceType, and Device Select. The right-hand side of the screen contains instructions for navigating the menu, such as 'Select Screen', 'Select Item', and 'Enter: Select'.

### 3.4.3.3 Device Select

The screenshot shows the 'Advanced' menu of the Aptio Setup - AMI. The 'Device Select' option is highlighted, and a sub-menu is open showing 'TPM 1.2', 'TPM 2.0', and 'Auto' as available options. The 'Auto' option is currently selected. The background menu items include TPM 2.0 Device Found, Security Device Support, SHA256 PCR Bank, Pending operation, Platform Hierarchy, Storage Hierarchy, Endorsement Hierarchy, Physical Presence Spec Version, TPM 2.0 InterfaceType, and Device Select. The right-hand side of the screen contains instructions for navigating the menu, such as 'Select Screen', 'Select Item', and 'Enter: Select'.

### 3.4.4 ACPI Settings

The screenshot shows the 'Advanced' section of the 'Aptio Setup - AMI' BIOS. Under 'ACPI Settings', the following options are listed:

- Enable ACPI Auto Configuration [Disabled]
- Enable Hibernation [Enabled]
- ACPI Sleep State [S3 (Suspend to RAM)]

A sub-menu for 'ACPI Sleep State' is displayed, showing the following options:

- Suspend Disabled
- S3 (Suspend to RAM)

The right-hand side of the screen contains a description: 'Select the highest ACPI sleep state the system will enter when the SUSPEND button is pressed.' Below this, a list of navigation keys is provided:

- ++: Select Screen
- ↑↓: Select Item
- Enter: Select
- +/-: Change Opt.
- F1: General Help
- F2: Previous Values
- F3: Optimized Defaults
- F4: Save & Exit
- ESC: Exit

### 3.4.5 Super IO Configuration

The screenshot shows the 'Advanced' section of the 'Aptio Setup - AMI' BIOS. Under 'IT8786 Super IO Configuration', the following options are listed:

- Super IO Chip IT8786
- Serial Port 1 Configuration
- Serial Port 2 Configuration
- Serial Port 3 Configuration
- Serial Port 4 Configuration
- Serial Port 5 Configuration
- Serial Port 6 Configuration
- Watch Dog Configuration

The right-hand side of the screen contains a description: 'Set Parameters of Serial Port 1 (COMA)'. Below this, a list of navigation keys is provided:

- ++: Select Screen
- ↑↓: Select Item
- Enter: Select
- +/-: Change Opt.
- F1: General Help
- F2: Previous Values
- F3: Optimized Defaults
- F4: Save & Exit
- ESC: Exit

### 3.4.5.1 Serial Port 1 Configuration

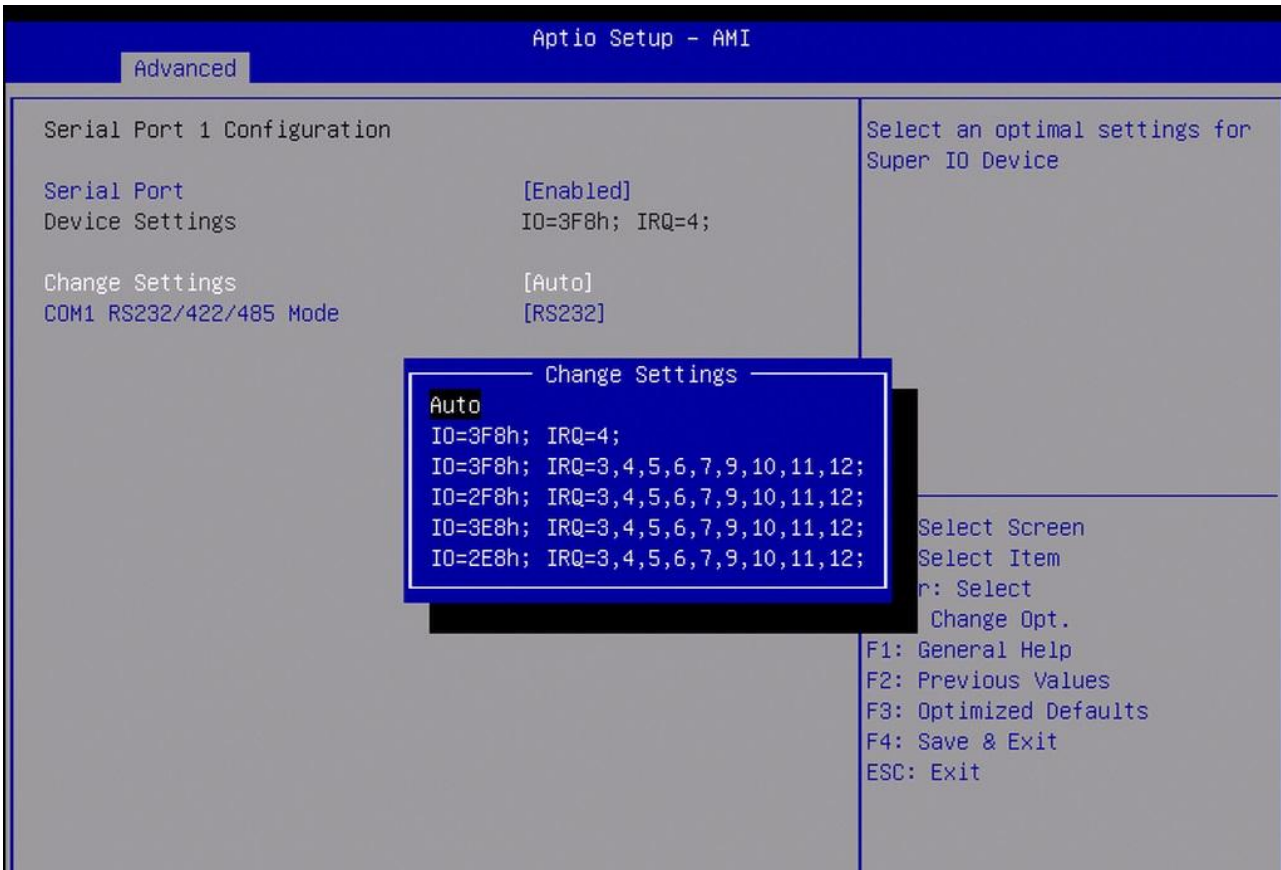

#### Com1 RS232/422/485 Mode

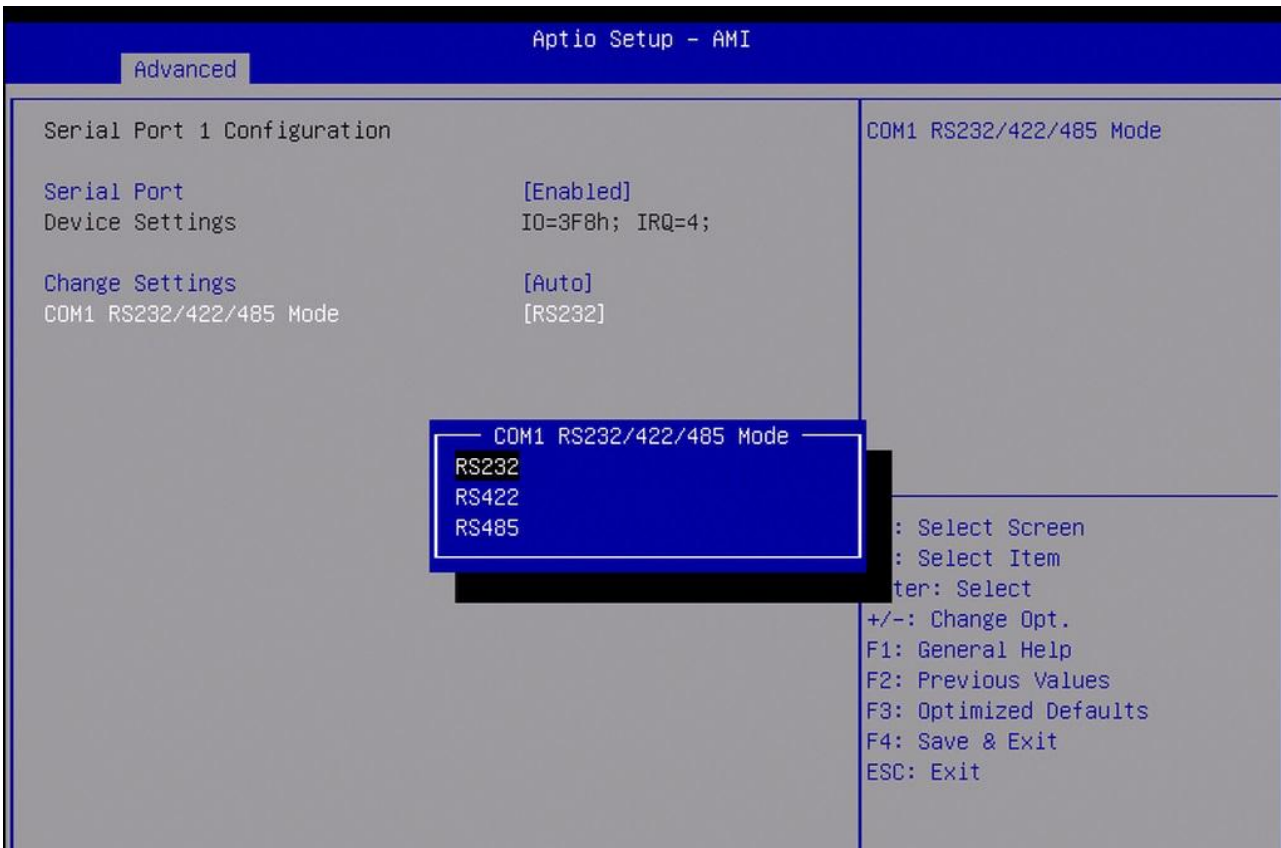

### 3.4.5.2 Serial Port 2 Configuration

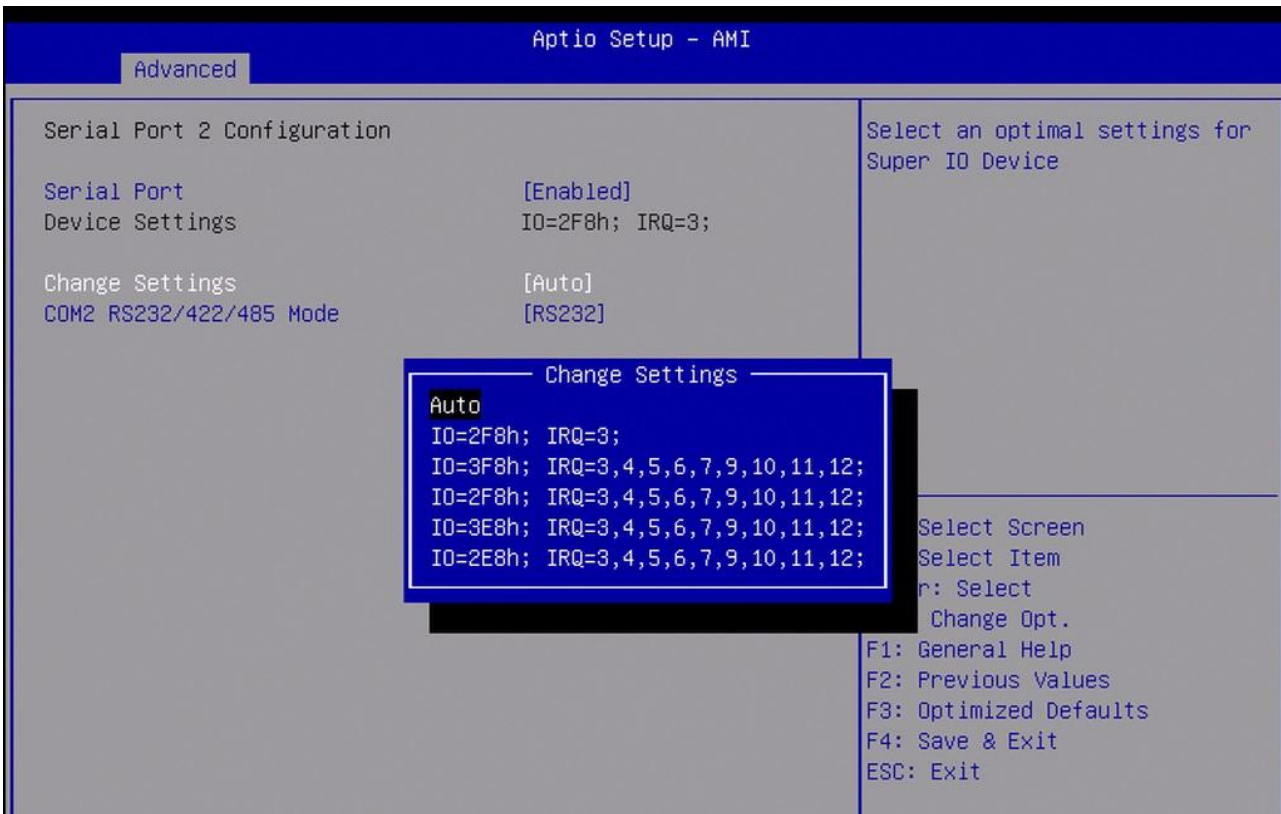

Com2 RS232/422/485 Mode

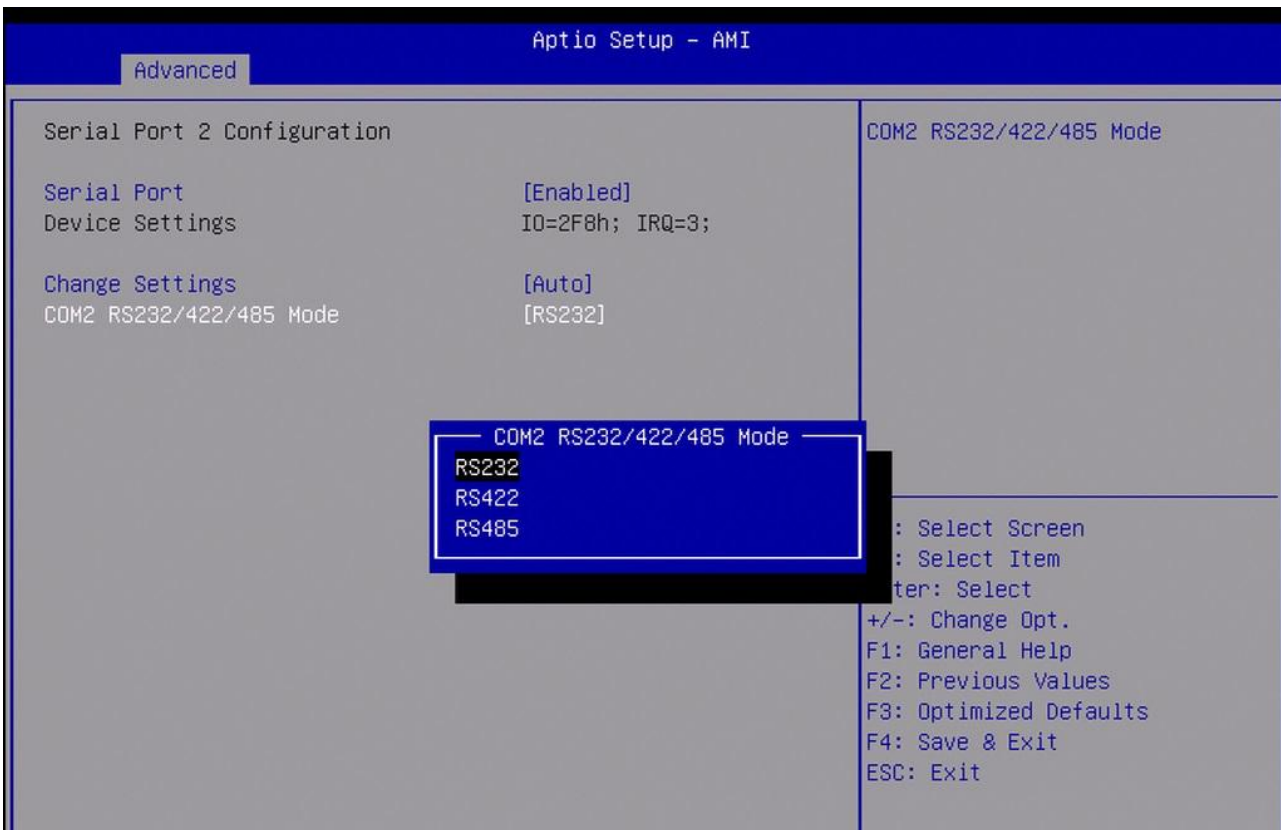

### 3.4.5.3 Serial Port 3 Configuration

Aptio Setup - AMI

Advanced

Serial Port 3 Configuration

Select an optimal settings for Super IO Device

Serial Port [Enabled]

Device Settings IO=3E8h; IRQ=6;

Change Settings [Auto]

Change Settings

Auto

IO=3E8h; IRQ=6;

IO=3E8h; IRQ=3,4,5,6,7,9,10,11,12;

IO=2E8h; IRQ=3,4,5,6,7,9,10,11,12;

IO=2F0h; IRQ=3,4,5,6,7,9,10,11,12;

IO=2E0h; IRQ=3,4,5,6,7,9,10,11,12;

Select Screen

Select Item

r: Select

Change Opt.

F1: General Help

F2: Previous Values

F3: Optimized Defaults

F4: Save & Exit

ESC: Exit

### 3.4.5.4 Serial Port 4 Configuration

Aptio Setup - AMI

Advanced

Serial Port 4 Configuration

Select an optimal settings for Super IO Device

Serial Port [Enabled]

Device Settings IO=2E8h; IRQ=7;

Change Settings [Auto]

Change Settings

Auto

IO=2E8h; IRQ=7;

IO=3E8h; IRQ=3,4,5,6,7,9,10,11,12;

IO=2E8h; IRQ=3,4,5,6,7,9,10,11,12;

IO=2F0h; IRQ=3,4,5,6,7,9,10,11,12;

IO=2E0h; IRQ=3,4,5,6,7,9,10,11,12;

Select Screen

Select Item

r: Select

Change Opt.

F1: General Help

F2: Previous Values

F3: Optimized Defaults

F4: Save & Exit

ESC: Exit

### 3.4.5.5 Serial Port 5 Configuration

Aptio Setup - AMI

Advanced

Serial Port 5 Configuration

Serial Port [Enabled]  
Device Settings IO=3E0h; IRQ=11;  
Change Settings [Auto]

Select an optimal settings for Super IO Device

Change Settings

Auto  
IO=2E0h; IRQ=10;  
IO=3E8h; IRQ=3,4,5,6,7,9,10,11,12;  
IO=2E8h; IRQ=3,4,5,6,7,9,10,11,12;  
IO=2F0h; IRQ=3,4,5,6,7,9,10,11,12;  
IO=2E0h; IRQ=3,4,5,6,7,9,10,11,12;

Select Screen  
Select Item  
r: Select  
Change Opt.  
F1: General Help  
F2: Previous Values  
F3: Optimized Defaults  
F4: Save & Exit  
ESC: Exit

### 3.4.5.6 Serial Port 6 Configuration

Aptio Setup - AMI

Advanced

Serial Port 6 Configuration

Serial Port [Enabled]  
Device Settings IO=2E0h; IRQ=10;  
Change Settings [Auto]

Select an optimal settings for Super IO Device

Change Settings

Auto  
IO=3E0h; IRQ=11;  
IO=3E8h; IRQ=3,4,5,6,7,9,10,11,12;  
IO=2E8h; IRQ=3,4,5,6,7,9,10,11,12;  
IO=2F0h; IRQ=3,4,5,6,7,9,10,11,12;  
IO=2E0h; IRQ=3,4,5,6,7,9,10,11,12;

Select Screen  
Select Item  
r: Select  
Change Opt.  
F1: General Help  
F2: Previous Values  
F3: Optimized Defaults  
F4: Save & Exit  
ESC: Exit

### 3.4.5.7 Watch Dog Configuration

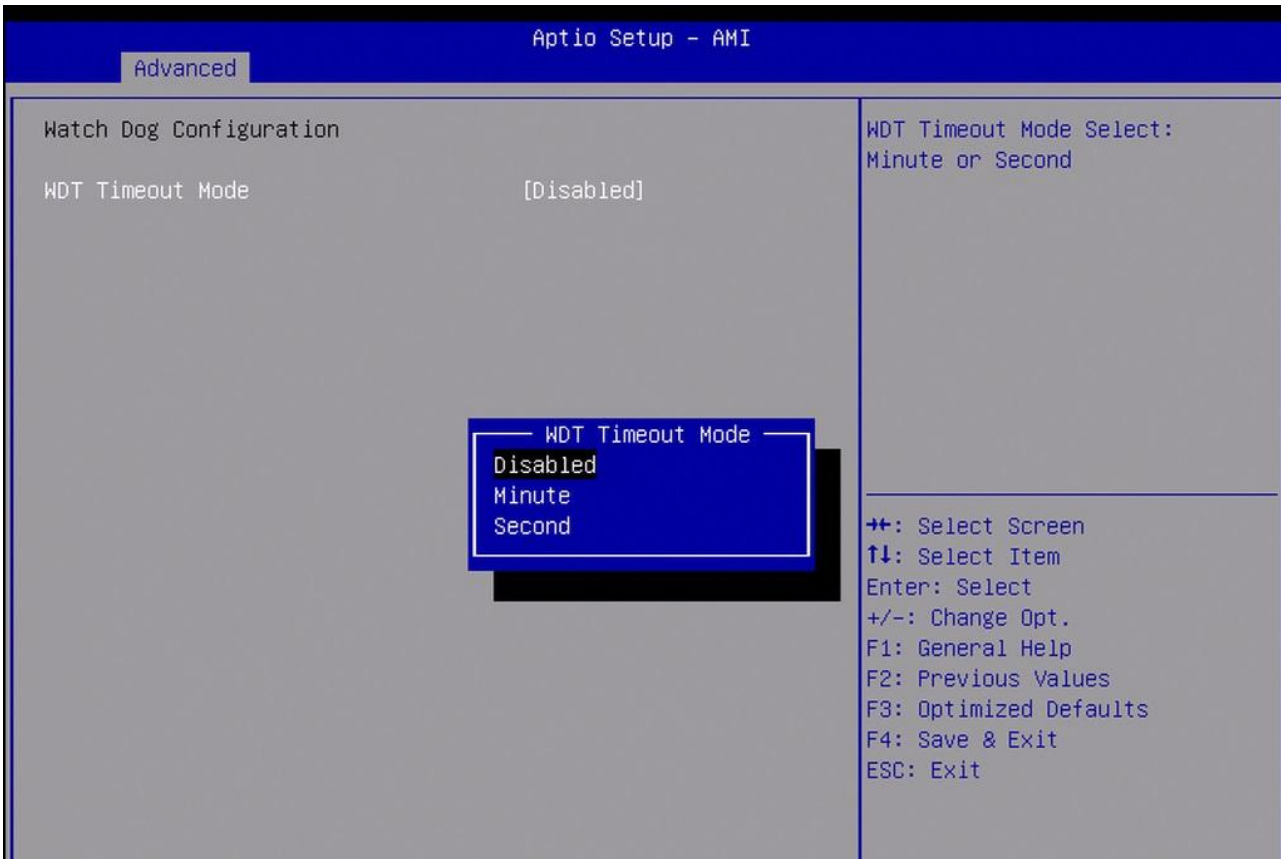

WDT Timeout Value:0~255 Minute



WDT Timeout Value:0~255 Second.

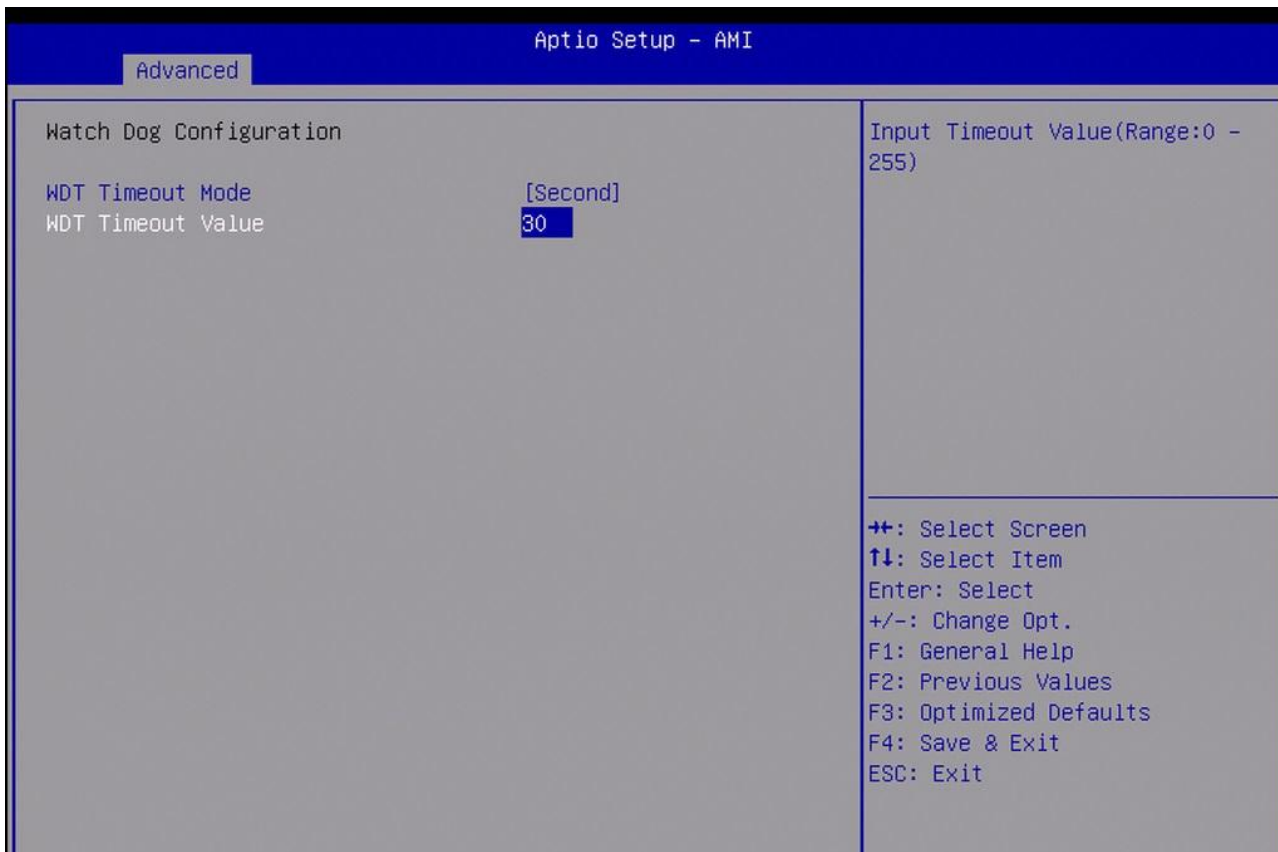

### 3.4.6 S5 RTC Wake Settings

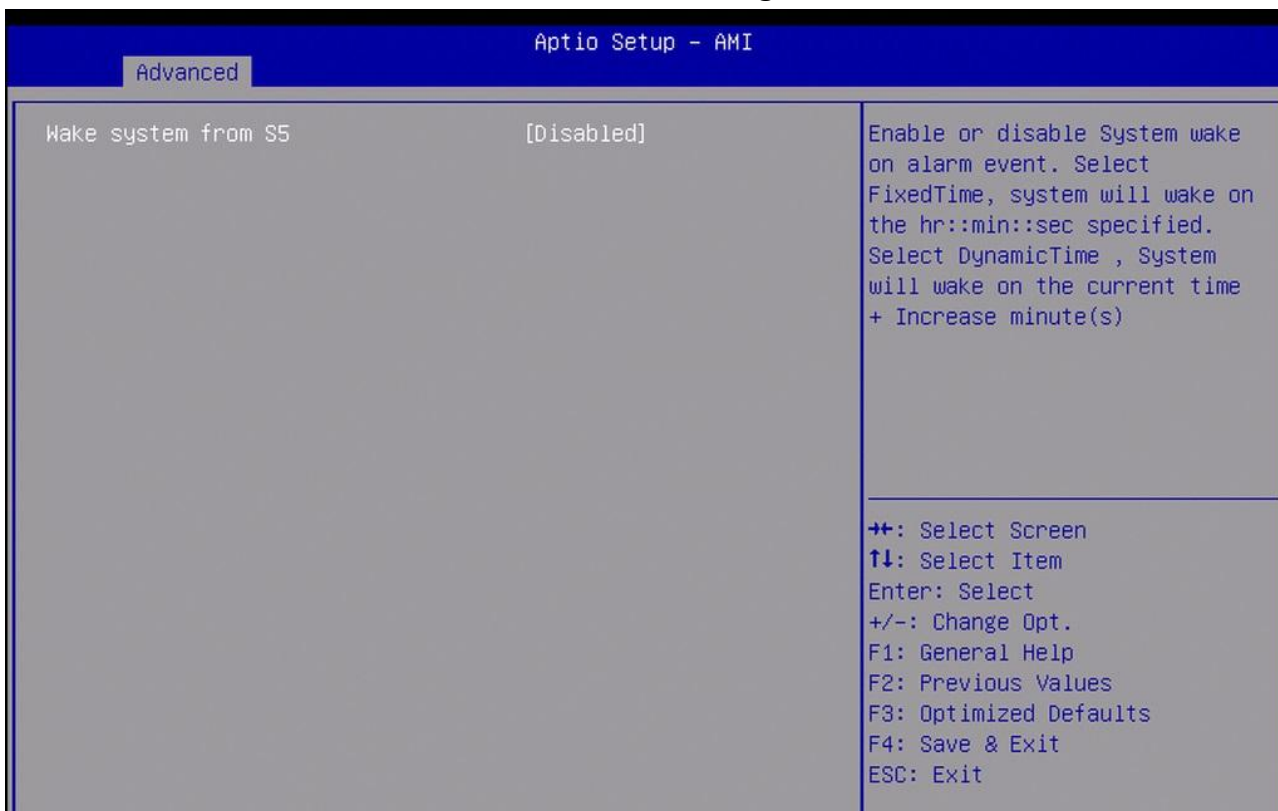

Wake up date: Select 0 for daily system wake up 1-31 for which day of the month that you would like the system to wake up

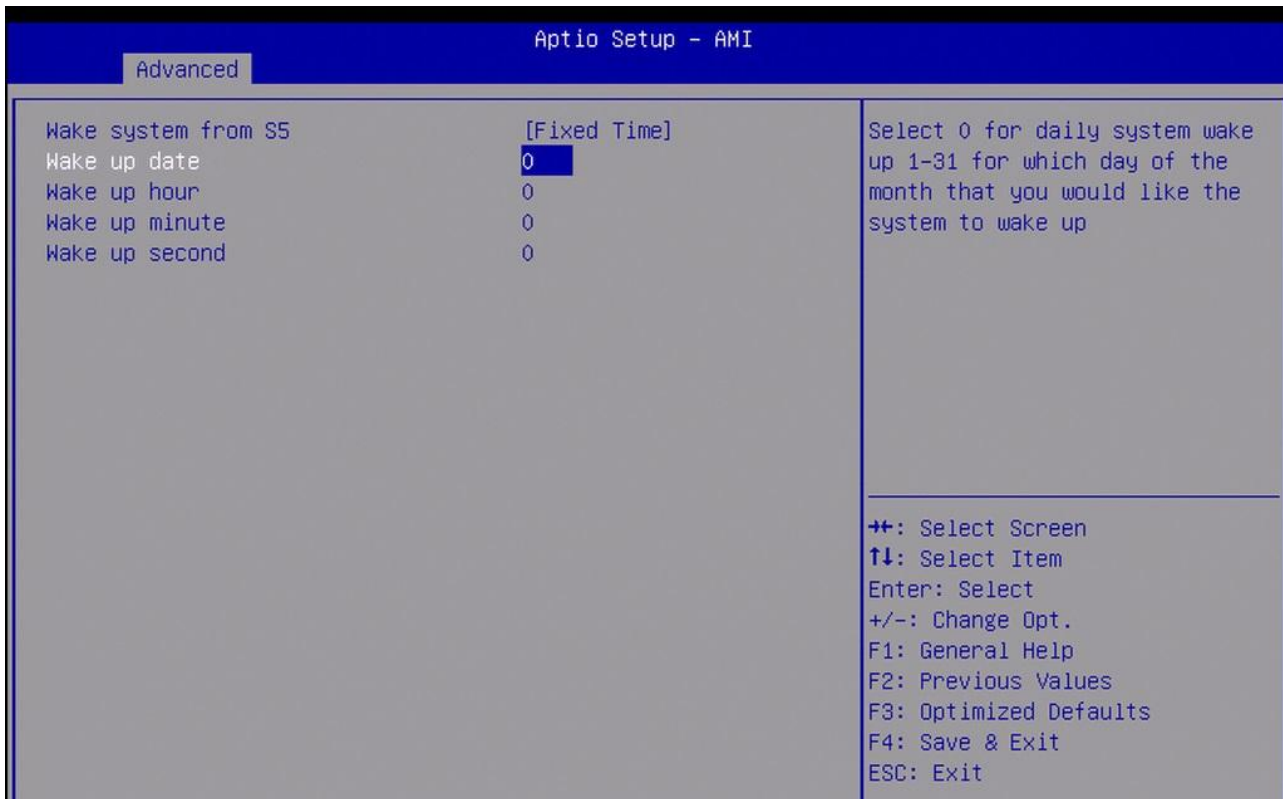

select 0-23 For example enter 3 for 3am and 15 for 3pm

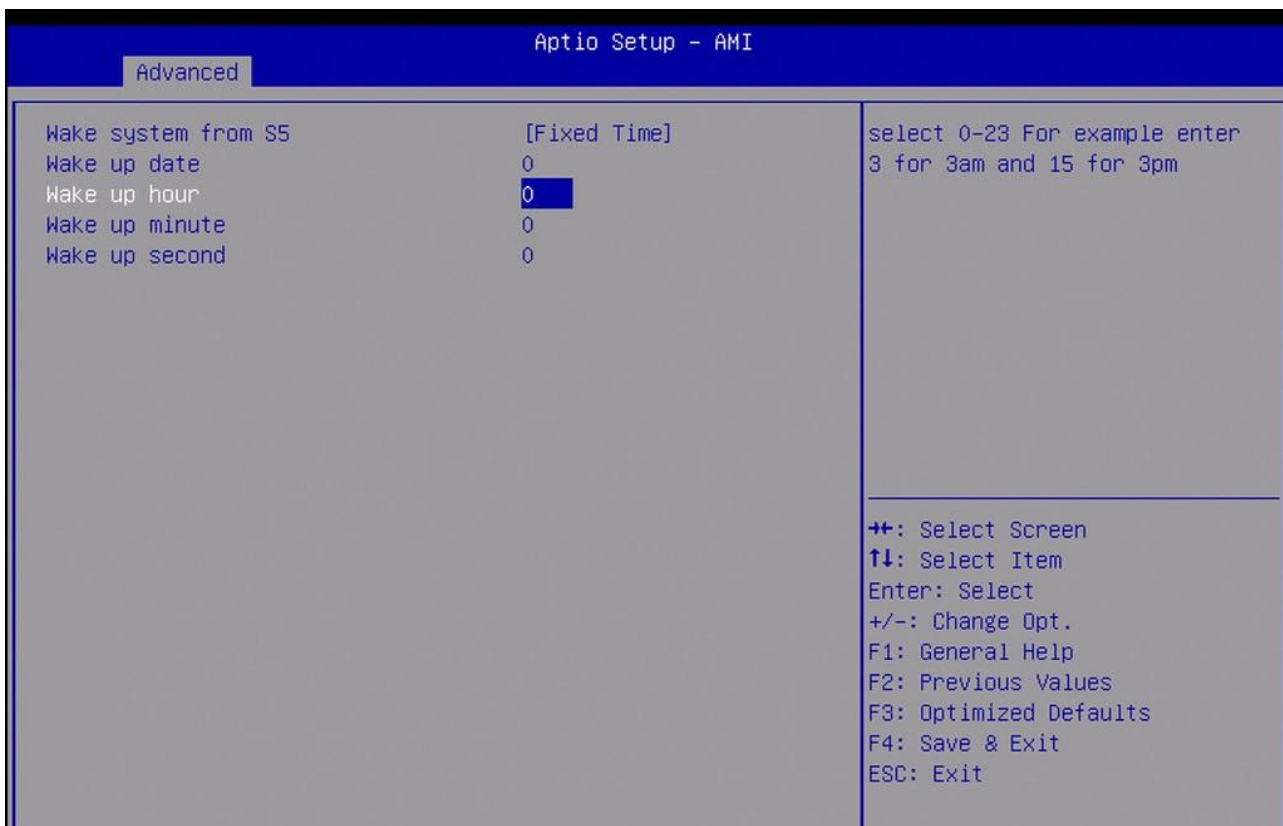

select 0-59 for Minute

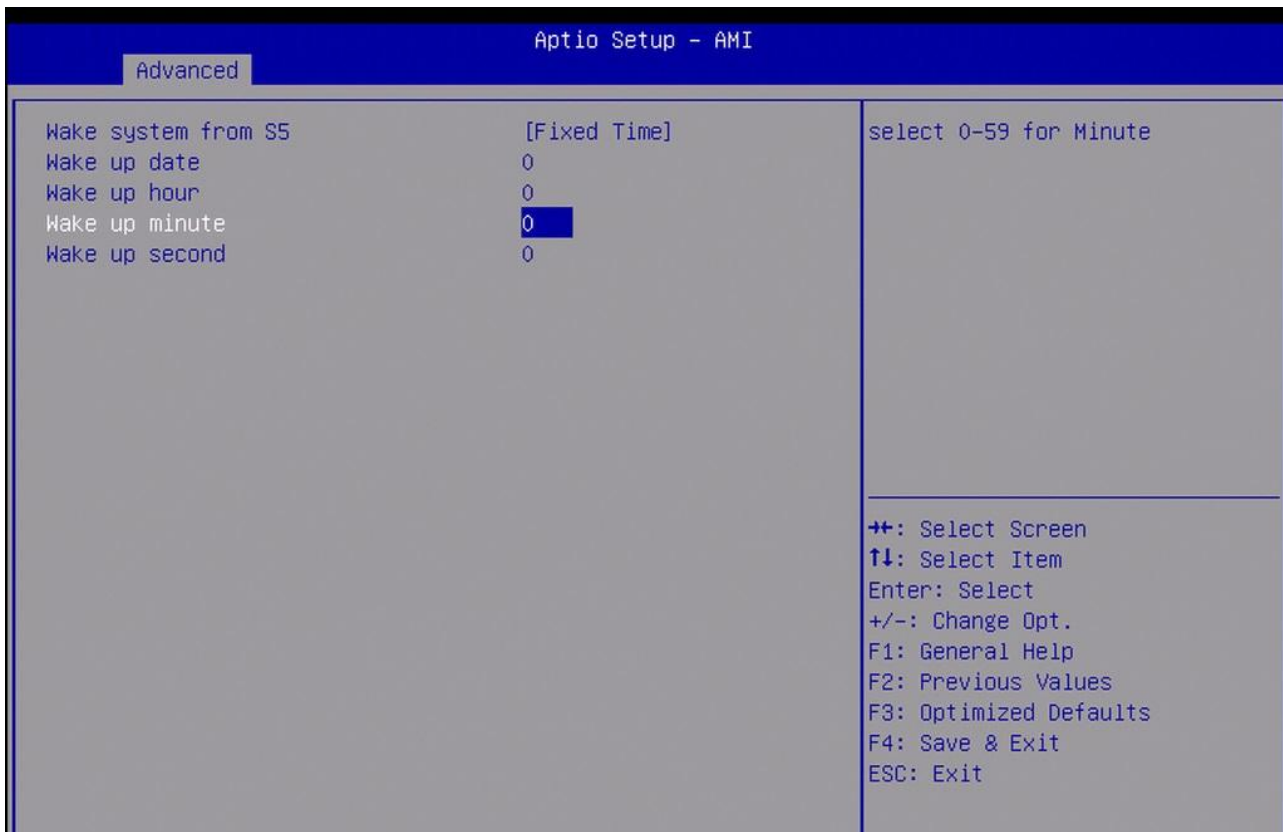

select 0-59 for Second

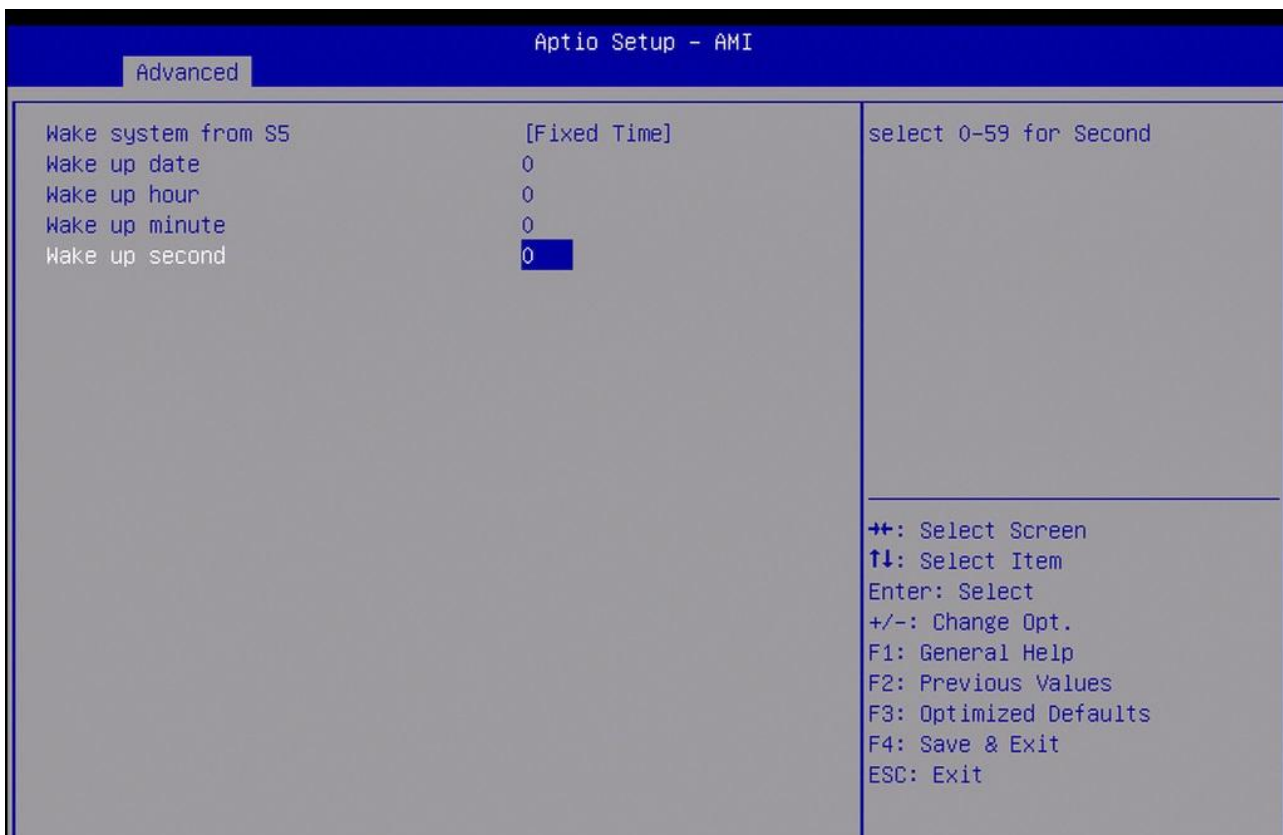

### 3.4.7 USB Configuration

Aptio Setup - AMI

Advanced

USB Configuration

USB Module Version 31

USB Controllers:  
2 XHCIs

USB Devices:  
1 Keyboard

Legacy USB Support [Enabled]

XHCI Hand-off

USB Mass Storage Driver Support

USB hardware delays and time-out

USB transfer time-out

Device reset time-out

Device power-up delay [Auto]

Enabled  
Disabled  
Auto

++: Select Screen  
↑↓: Select Item  
Enter: Select  
+/-: Change Opt.  
F1: General Help  
F2: Previous Values  
F3: Optimize Defaults  
F4: Save & Exit  
ESC: Exit

#### 3.4.7.1 USB transfer time-out

Aptio Setup - AMI

Advanced

USB Configuration

USB Module Version 31

USB Controllers:  
2 XHCIs

USB Devices:  
1 Keyboard

Legacy USB Support

XHCI Hand-off

USB Mass Storage Driver Support

USB hardware delays and time-out

USB transfer time-out

Device reset time-out

Device power-up delay [Auto]

1 sec  
5 sec  
10 sec  
20 sec

+: Select Screen  
↓: Select Item  
Enter: Select  
+/-: Change Opt.  
F1: General Help  
F2: Previous Values  
F3: Optimize Defaults  
F4: Save & Exit  
ESC: Exit

Version 2.22.1288 Copyright (C) 2024 AMI

### 3.4.7.2 Device reset time-out

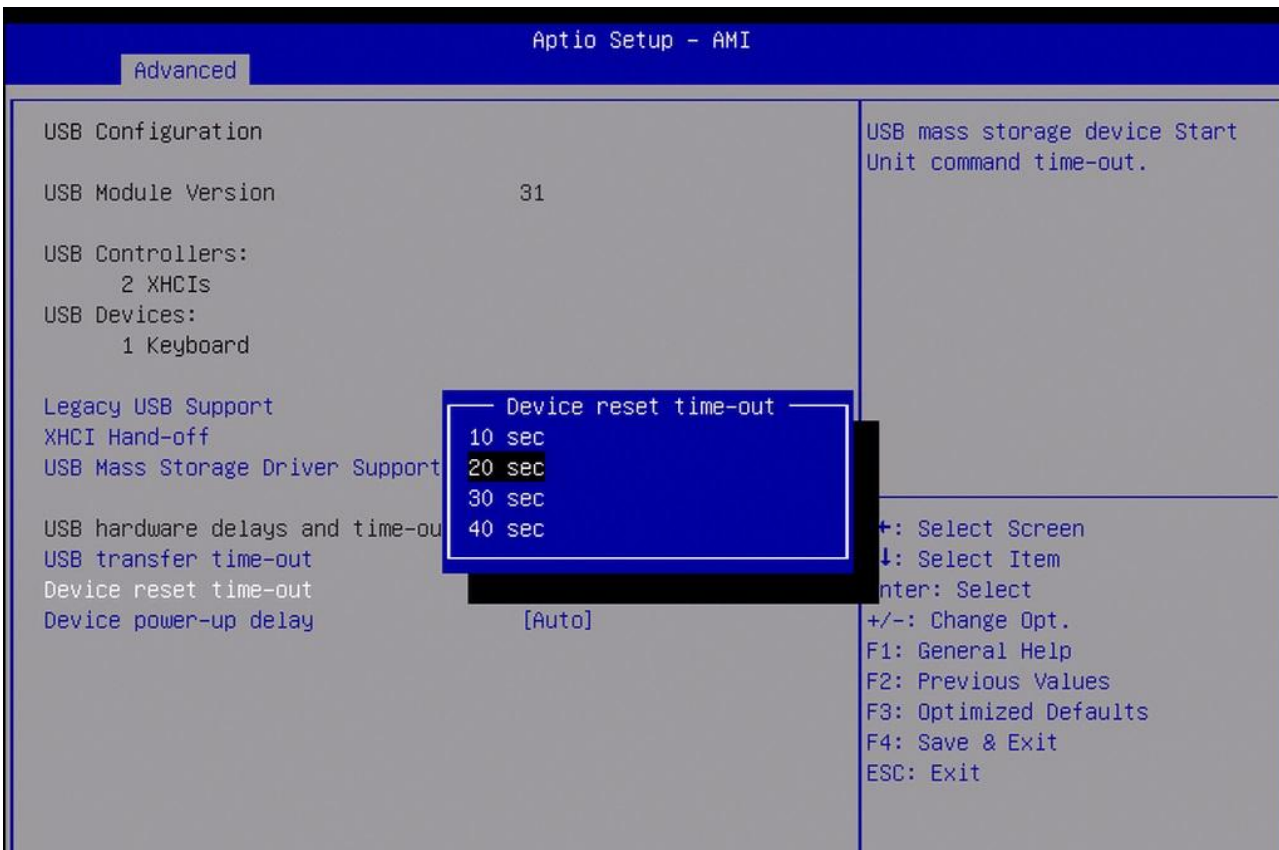

### 3.4.7.3 Device power-up delay

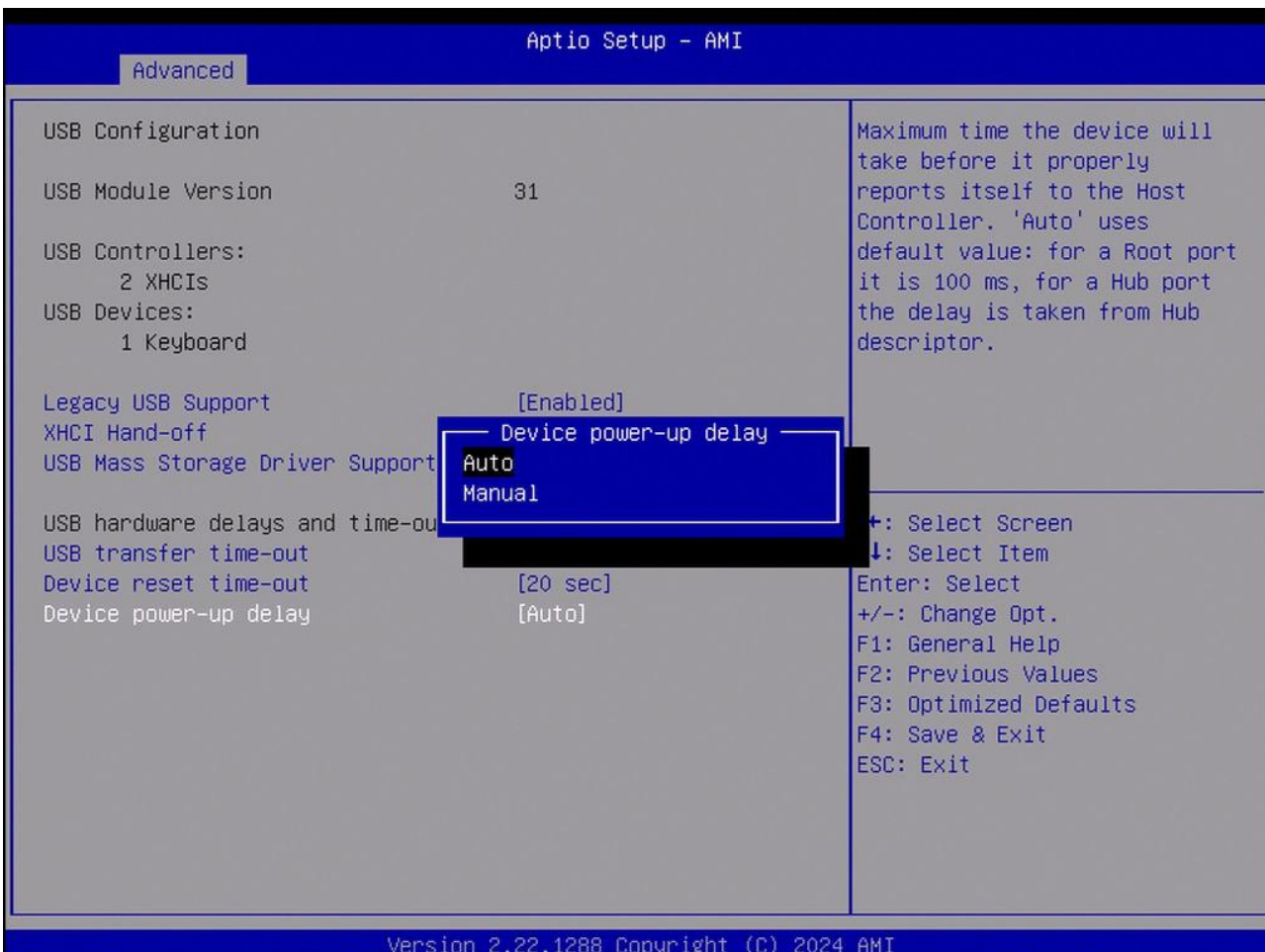

Version 2.22.1288 Copyright (C) 2024 AMI

### 3.4.8 Network Stack Configuration

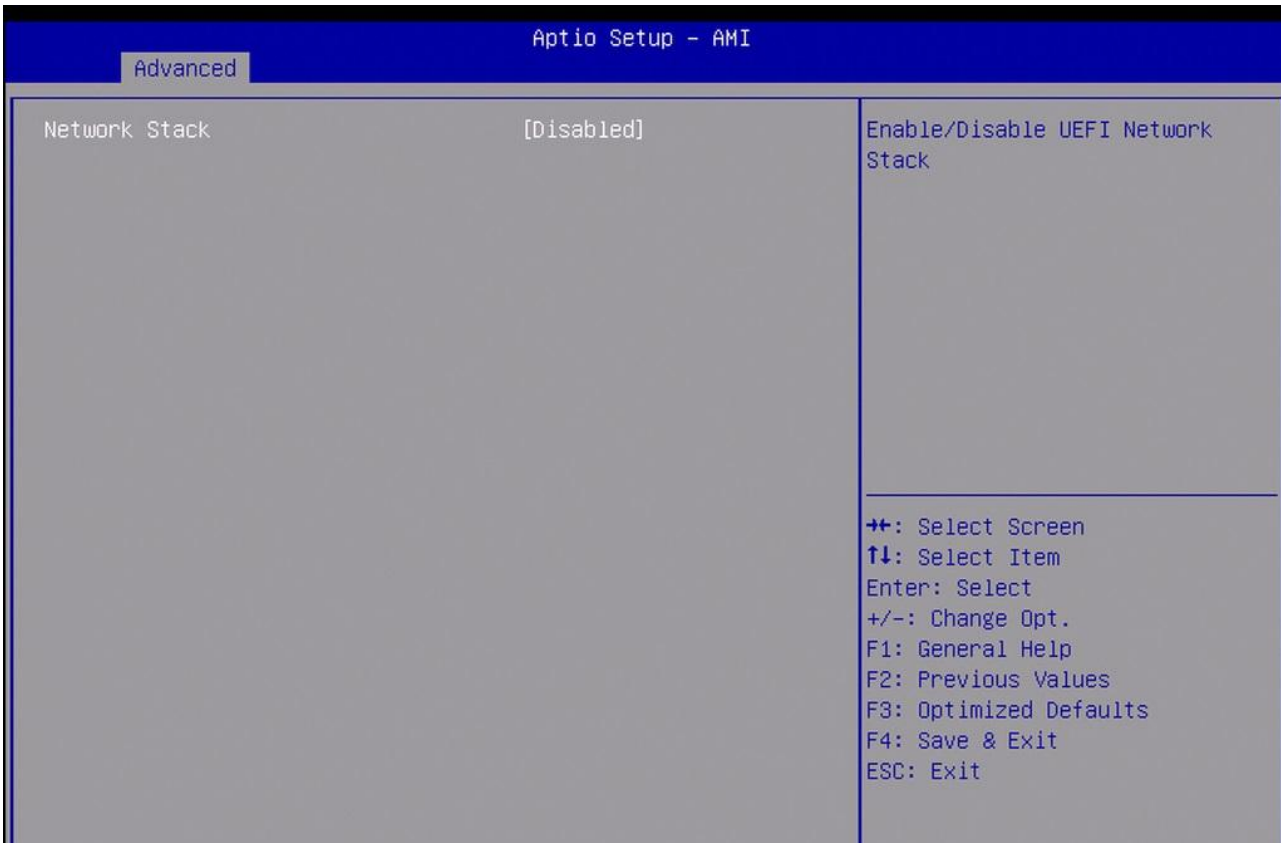

#### 3.4.8.1 PXE boot wait time

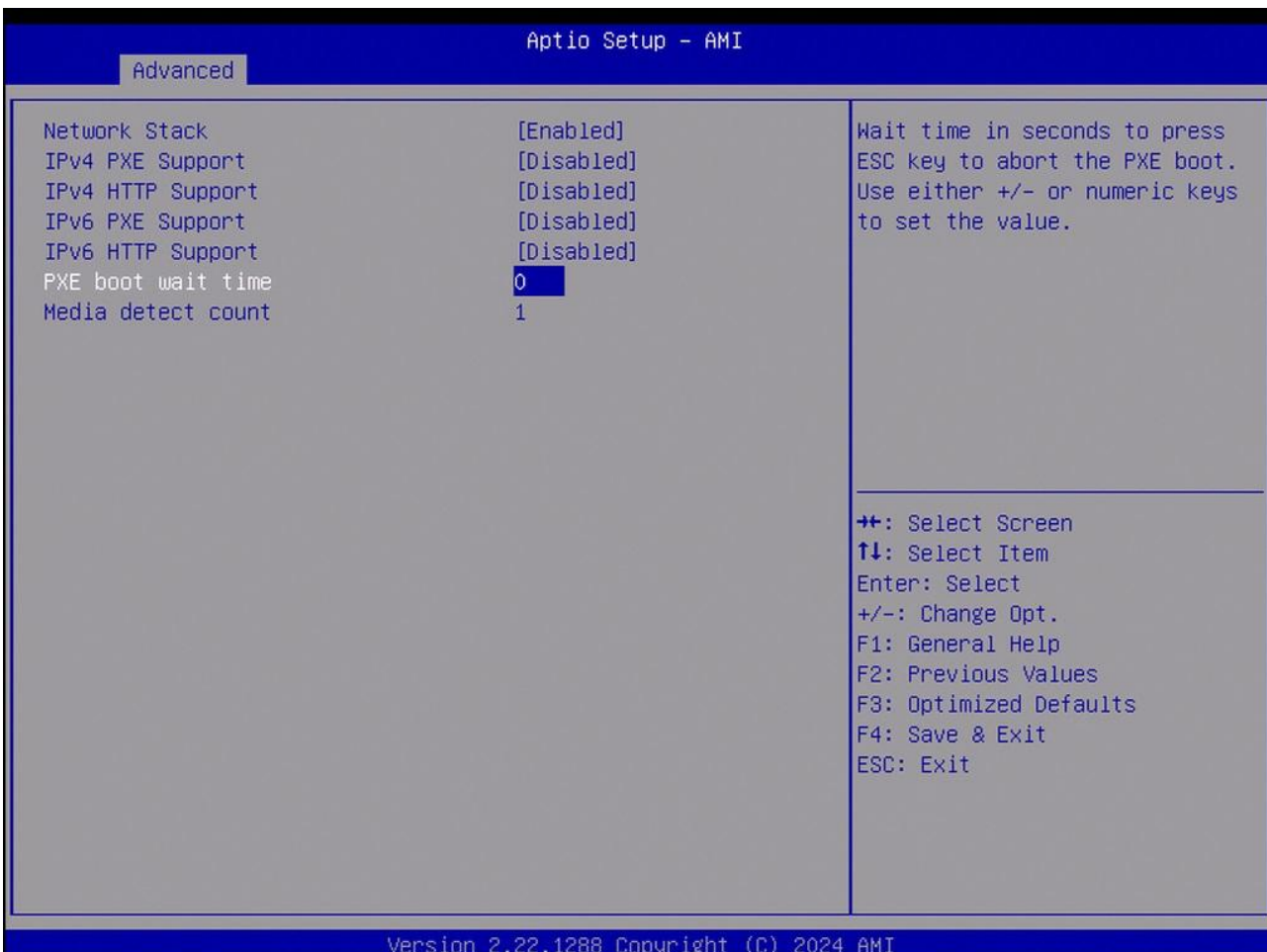

### 3.4.8.2 Media detect count

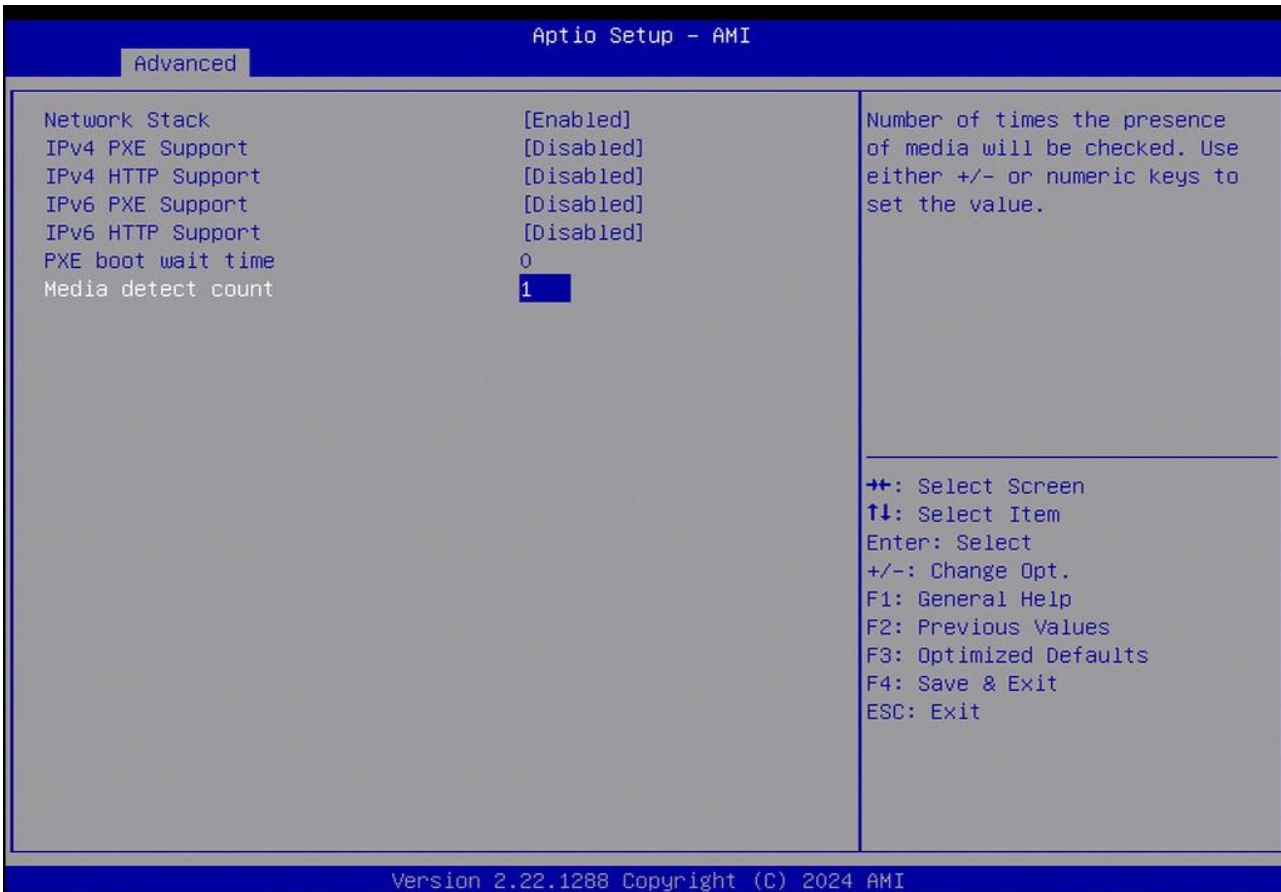

### 3.4.9 NVMe Configuration

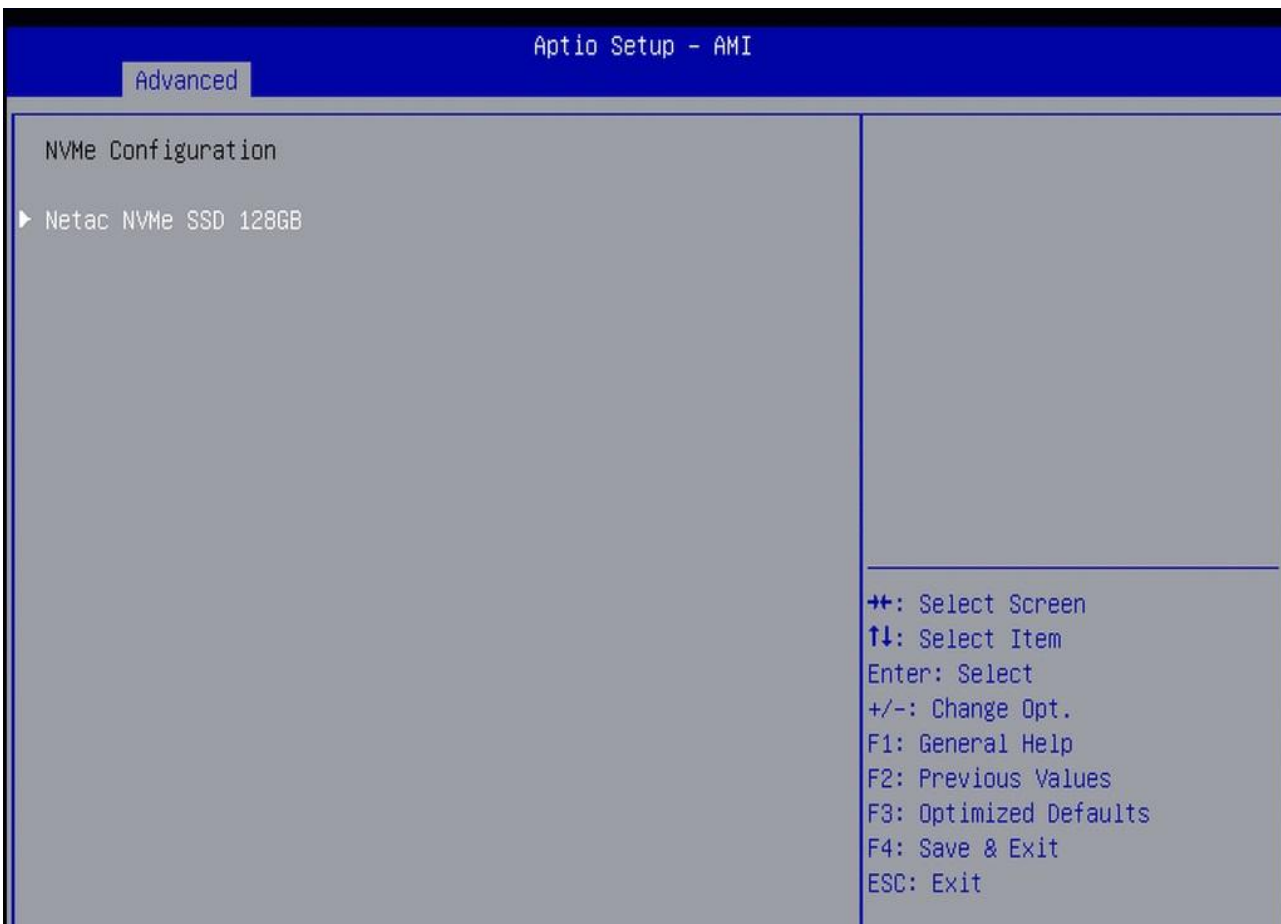

### 3.4.9.1 Netac NVME SSD 128GB information(This is a sample, and the information displayed by the user is subject to actual conditions)

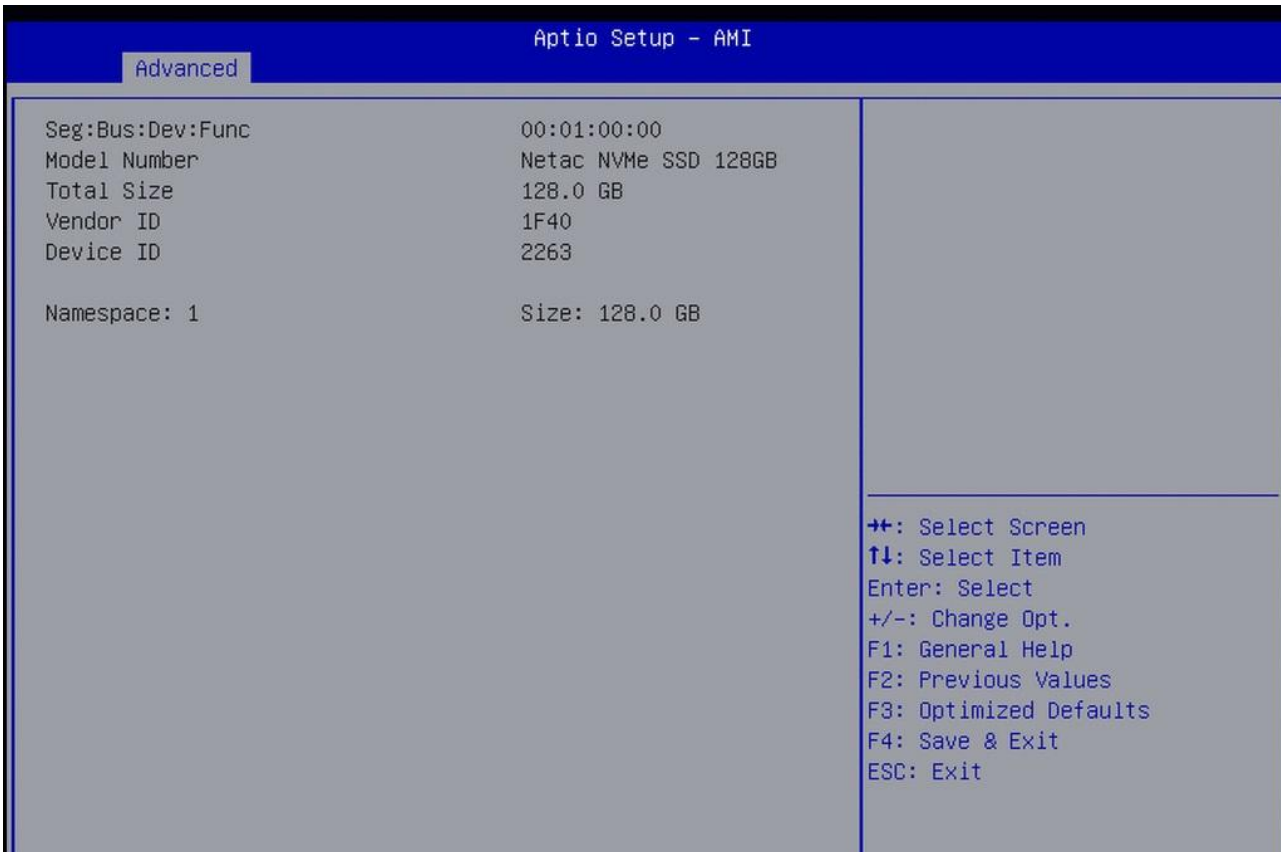

### 3.4.10 Intel(R)I210 Gigabit Network Connention

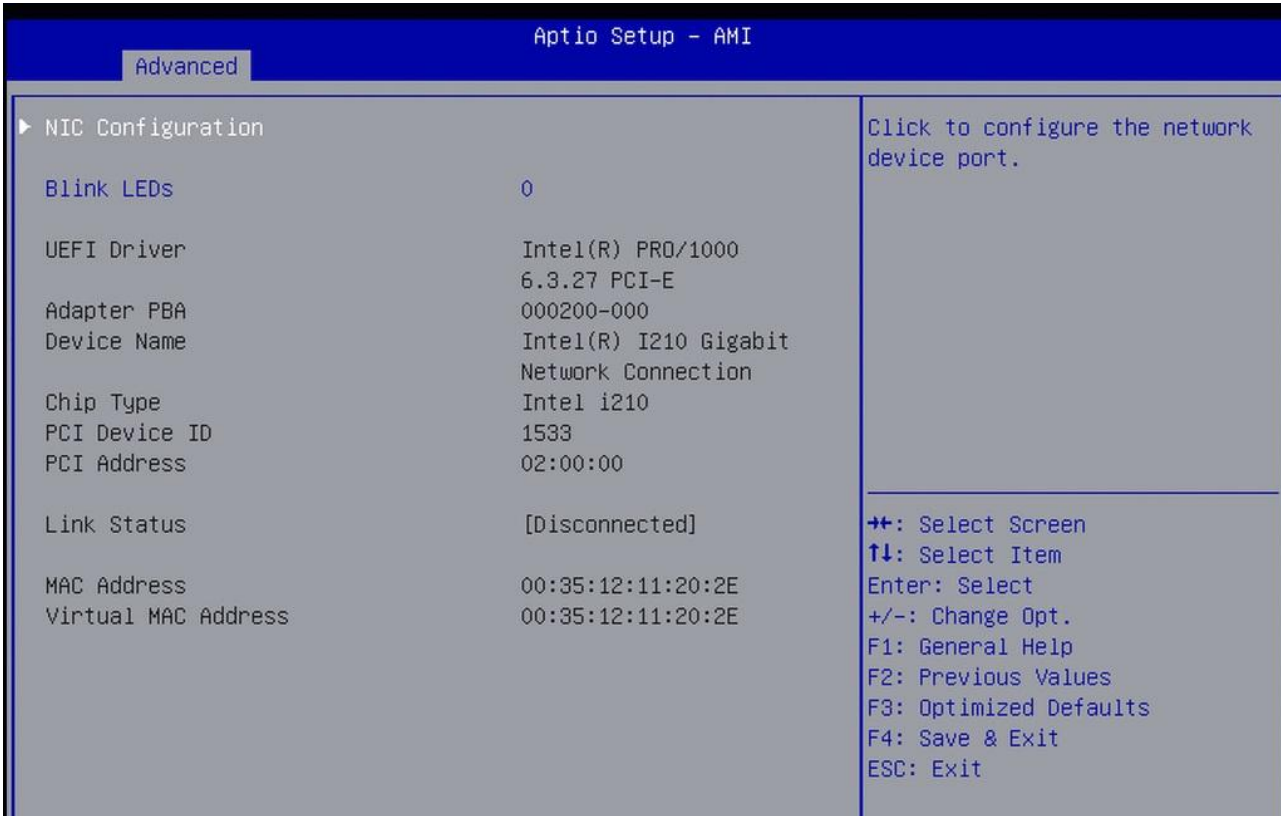

## NIC Configuration

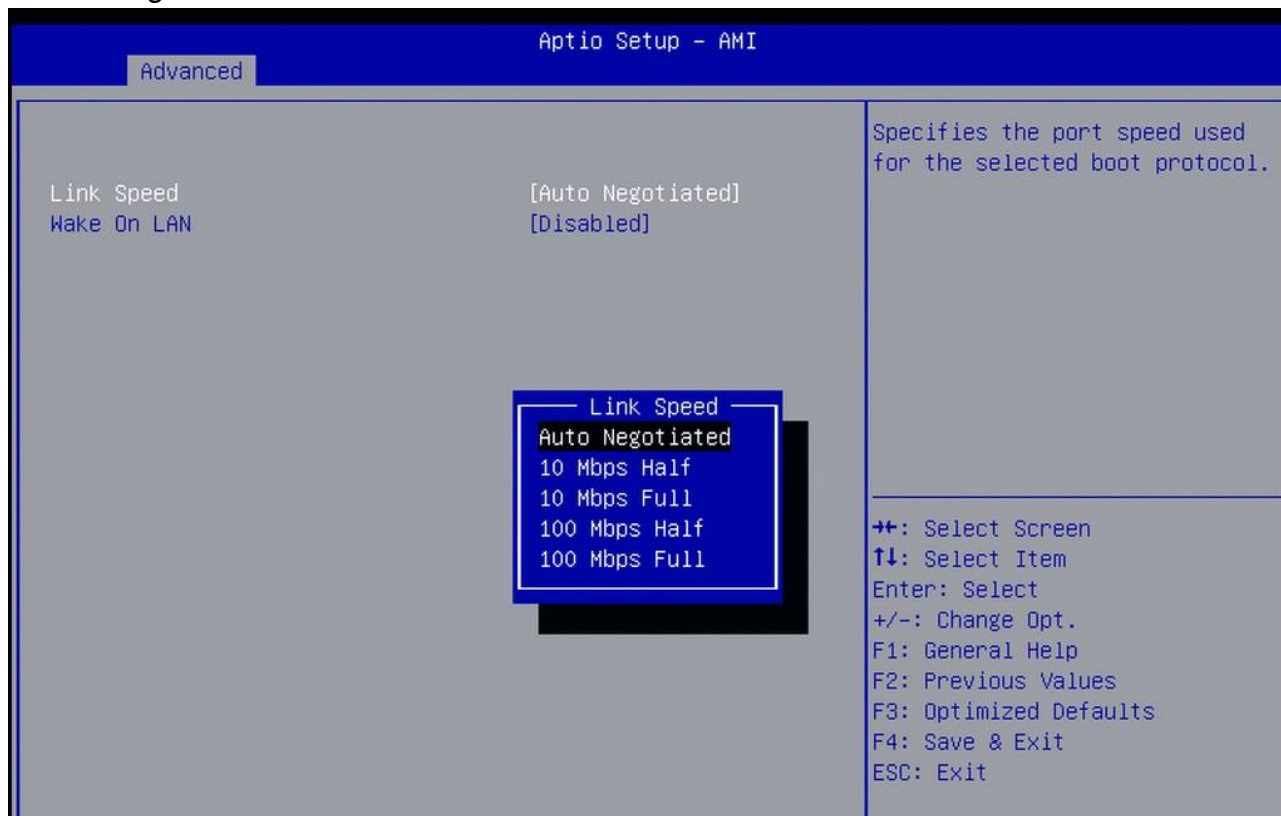

### 3.4.11 Intel(R) Ethernet Connection(16) I219-V

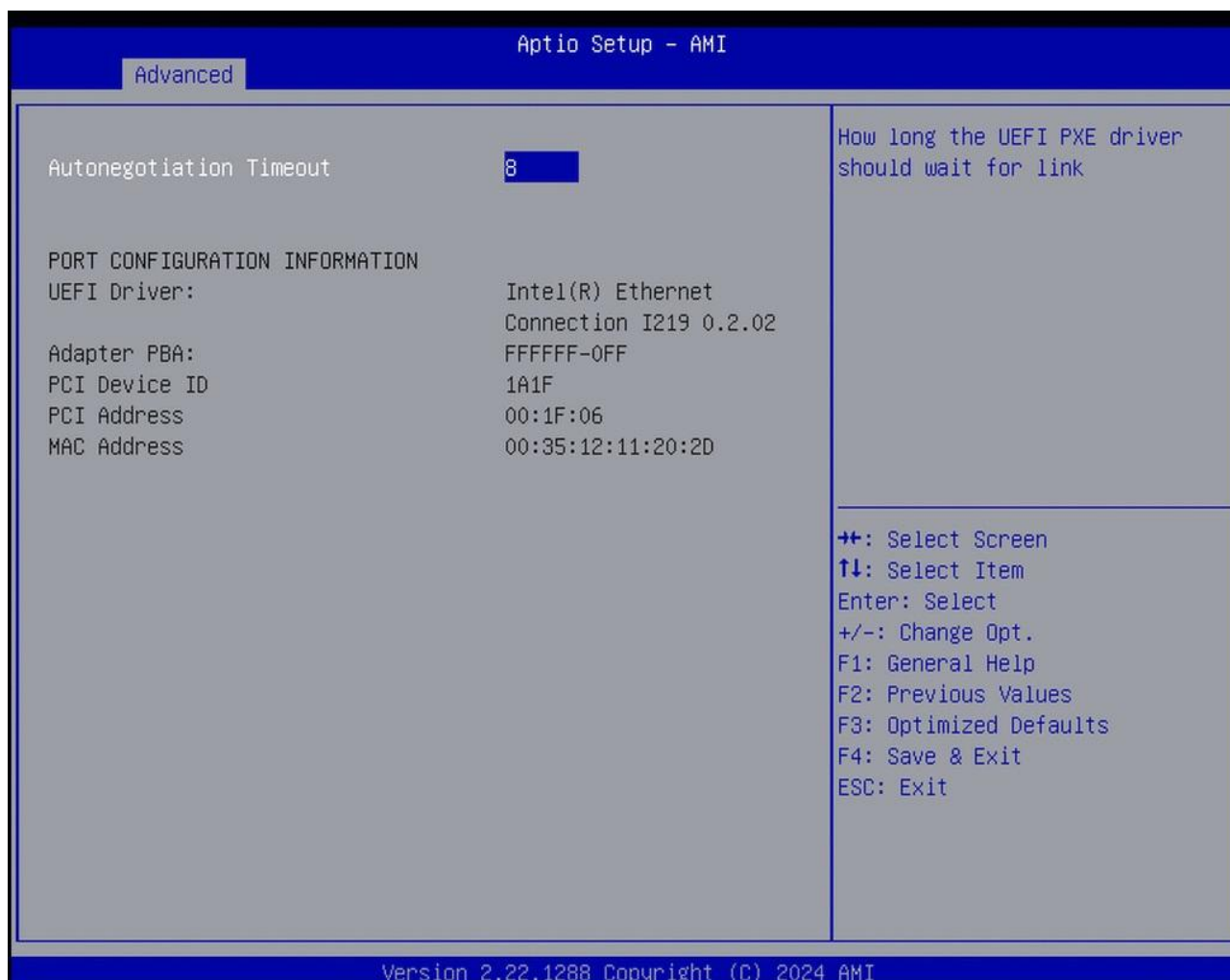

### 3.5 Chipset Settings



#### 3.5.1 System Agent (SA) Configuration



### 3.5.1.1 Memory Configuration

Aptio Setup - AMI

Chipset

Memory Configuration

Memory RC Version	0.0.4.133
Memory Frequency	2667 MHz
tCL-tRCD-tRP-tRAS	19-19-19-43
MC 0 Ch 0 DIMM 0	Not Populated / Disabled
MC 0 Ch 0 DIMM 1	Not Populated / Disabled
MC 1 Ch 0 DIMM 0	Populated & Enabled
Size	8192 MB (DDR4)
Number of Ranks	1
Manufacturer	Kingston
MC 1 Ch 0 DIMM 1	Not Populated / Disabled

++: Select Screen  
↑↓: Select Item  
Enter: Select  
+/-: Change Opt.  
F1: General Help  
F2: Previous Values  
F3: Optimized Defaults  
F4: Save & Exit  
ESC: Exit

### 3.5.1.2 Graphics Configuration

Aptio Setup - AMI

Chipset

Graphics Configuration

GTT Size	[8MB]
Aperture Size	[256MB]
DVMT Pre-Allocated	[60M]

Select the GTT Size

2MB  
4MB  
8MB

++: Select Screen  
↑↓: Select Item  
Enter: Select  
+/-: Change Opt.  
F1: General Help  
F2: Previous Values  
F3: Optimized Defaults  
F4: Save & Exit  
ESC: Exit

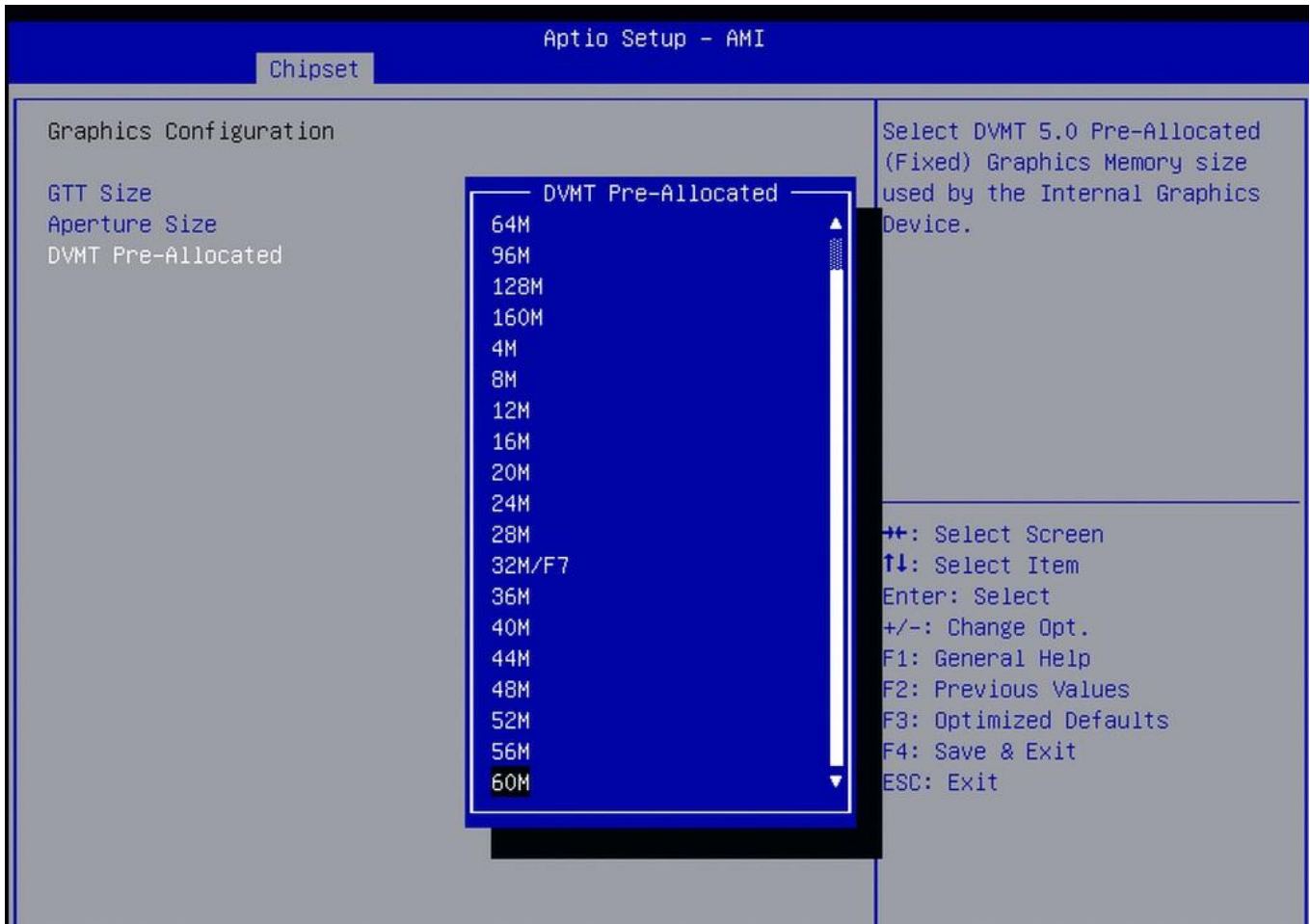
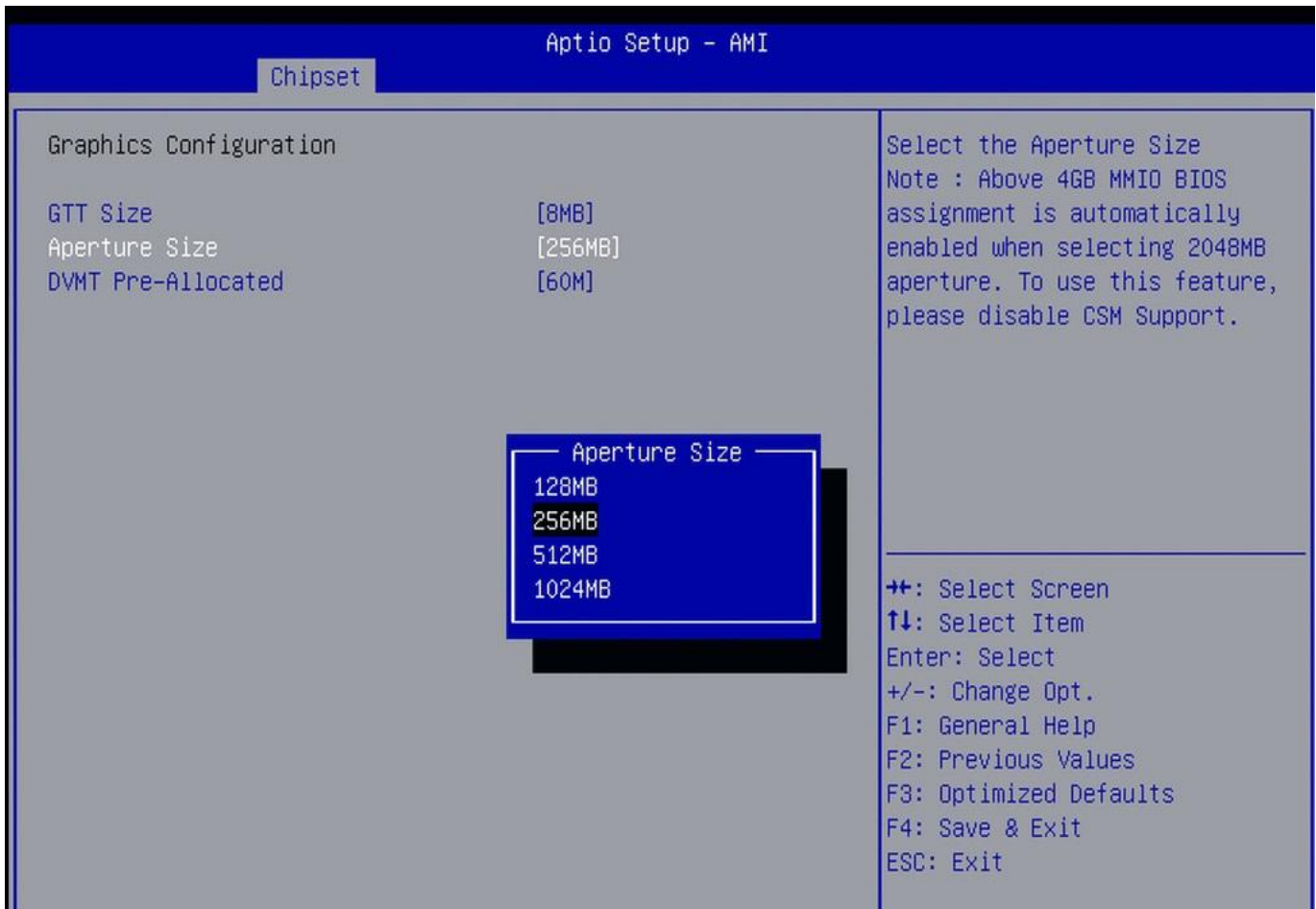

### 3.5.1.3 VMD Configuration



### 3.5.2 PCH-IO Configuration

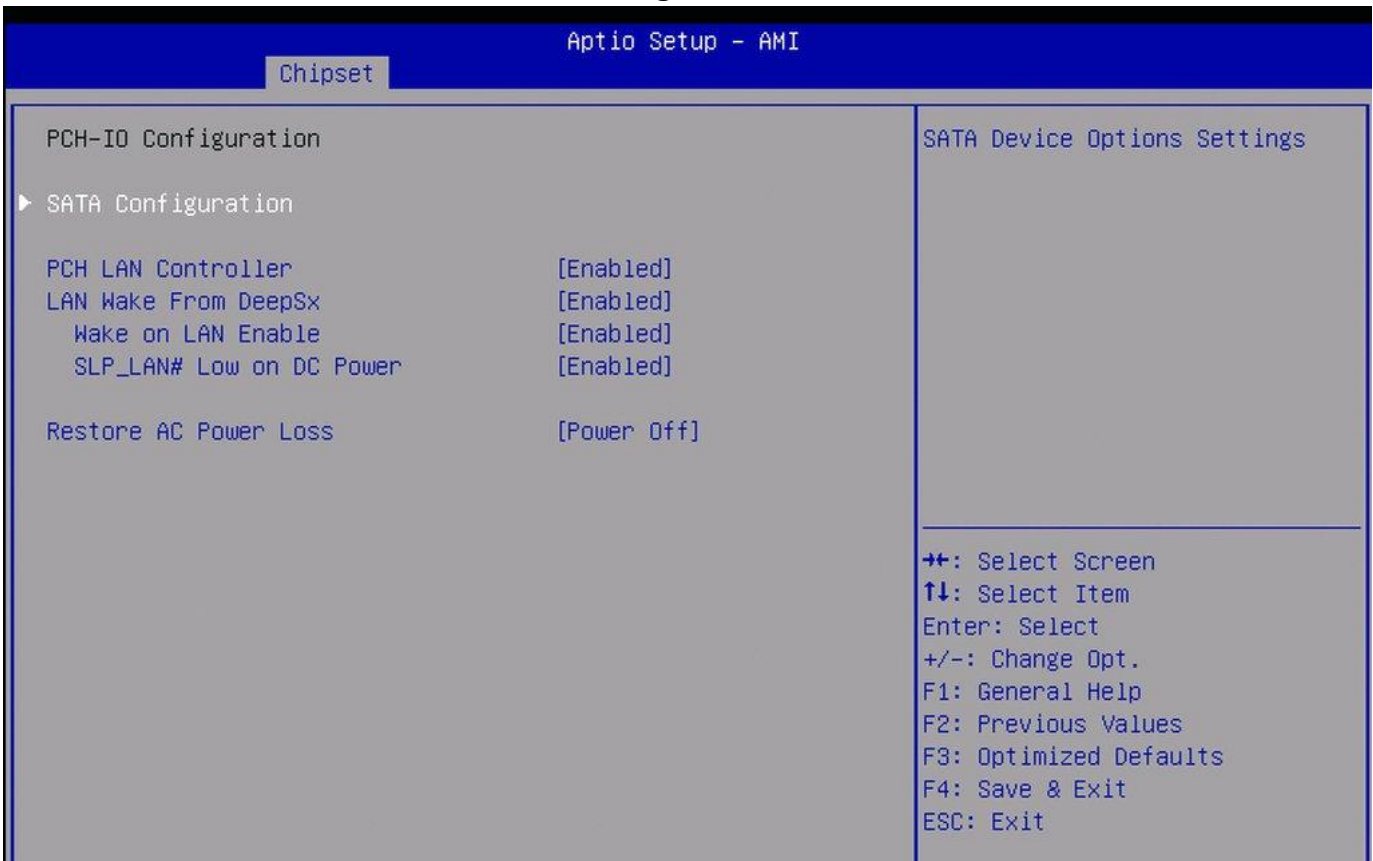

### 3.5.2.1 SATA Configuration

Aptio Setup - AMI

Chipset

SATA Configuration		▲ Identify the SATA port is connected to Solid State Drive or Hard Disk Drive
SATA Controller(s)	[Enabled]	
SATA Mode Selection	[AHCI]	
SATA Test Mode	[Disabled]	
Aggressive LPM Support	[Enabled]	
Serial ATA Port 0		
Software Preserve	Unknown	
Port 0	[Enabled]	
Hot Plug	[Disabled]	
Configured as eSATA	Hot Plug supported	
External	[Disabled]	
Spin Up Device	[Disabled]	++: Select Screen
SATA Device Type	[Hard Disk Drive]	↑↓: Select Item
Topology	[Unknown]	Enter: Select
SATA Port 0 DevSlp	[Disabled]	+/-: Change Opt.
DITO Configuration	[Disabled]	F1: General Help
DITO Value	625	F2: Previous Values
DM Value	15	F3: Optimized Defaults
Serial ATA Port 1	Empty	F4: Save & Exit
Software Preserve	Unknown	ESC: Exit
Port 1	[Enabled]	
Hot Plug	[Disabled]	
Configured as eSATA	Hot Plug supported	

Aptio Setup - AMI

Chipset

Software Preserve		▲ Enable/Disable DITO Configuration
Port 1	[Enabled]	
Hot Plug	[Disabled]	
Configured as eSATA	Hot Plug supported	
External	[Disabled]	
Spin Up Device	[Disabled]	
SATA Device Type	[Hard Disk Drive]	
Topology	[Unknown]	
SATA Port 1 DevSlp	[Disabled]	
DITO Configuration	[Disabled]	
DITO Value	625	
DM Value	15	
Serial ATA Port 2		
Software Preserve	Unknown	
Port 2	[Enabled]	++: Select Screen
Hot Plug	[Disabled]	↑↓: Select Item
Configured as eSATA	Hot Plug supported	Enter: Select
External	[Disabled]	+/-: Change Opt.
Spin Up Device	[Disabled]	F1: General Help
SATA Device Type	[Hard Disk Drive]	F2: Previous Values
Topology	[Unknown]	F3: Optimized Defaults
SATA Port 2 DevSlp	[Disabled]	F4: Save & Exit
DITO Configuration	[Disabled]	ESC: Exit
DITO Value	625	
DM Value	15	

Version 2.22.1288 Copyright (C) 2024 AMI

### 3.5.2 Restore AC Power Loss

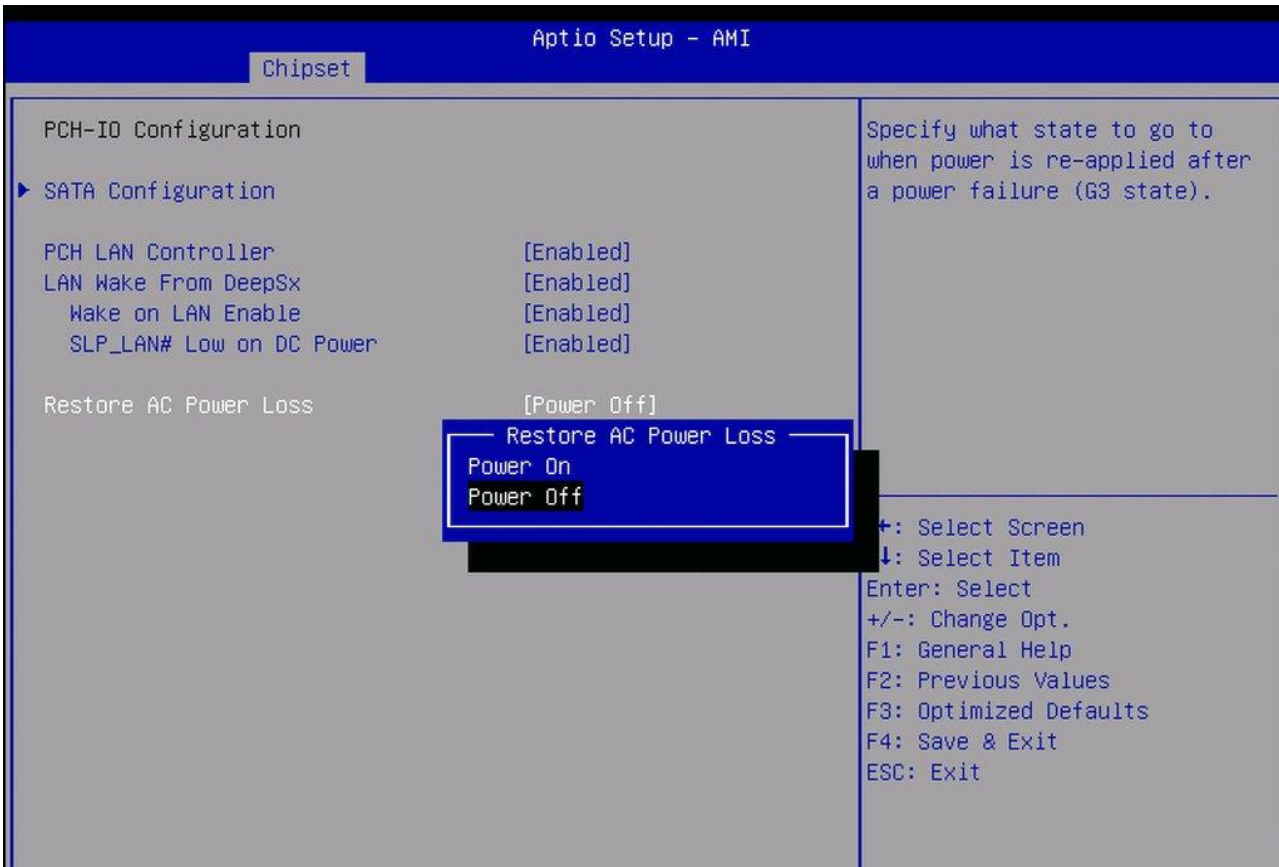

### 3.5.3 LCD Control

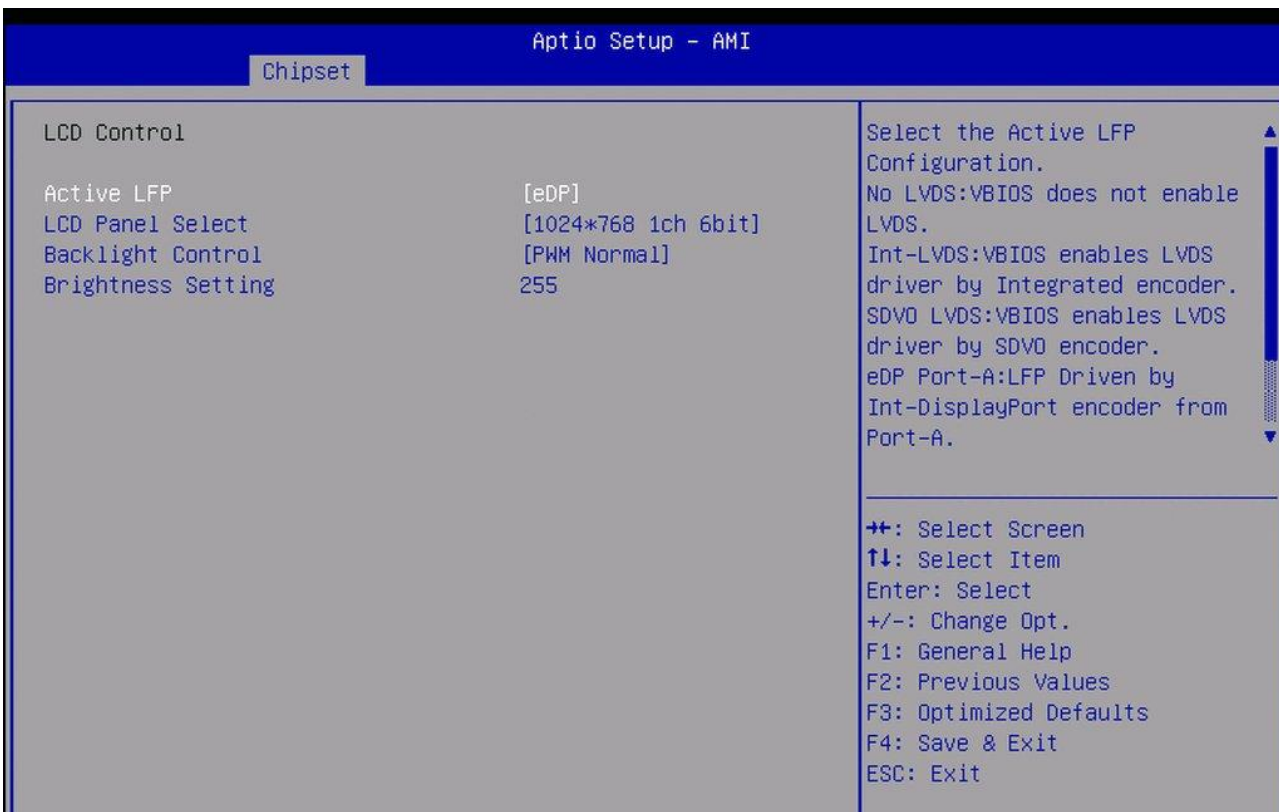

### 3.5.3.1 Active LFP

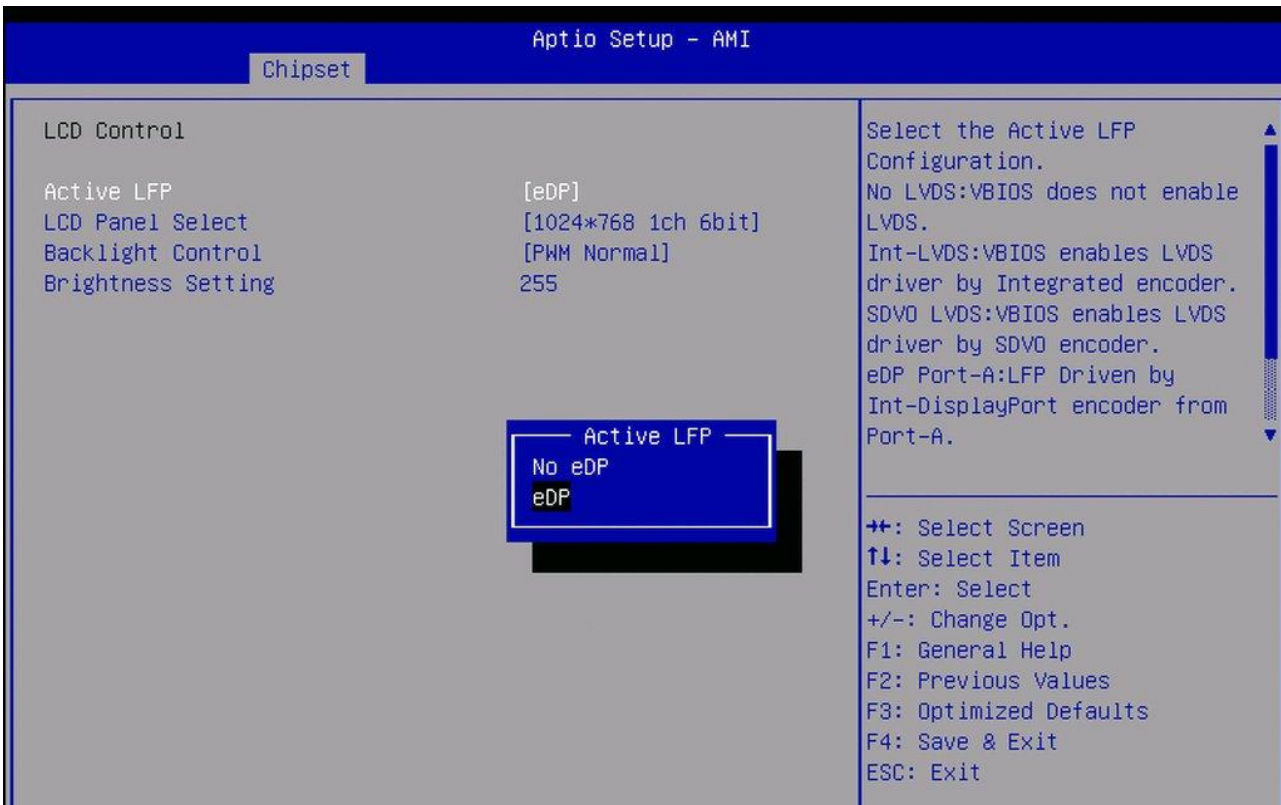

### 3.5.3.2 LCD Panel Select

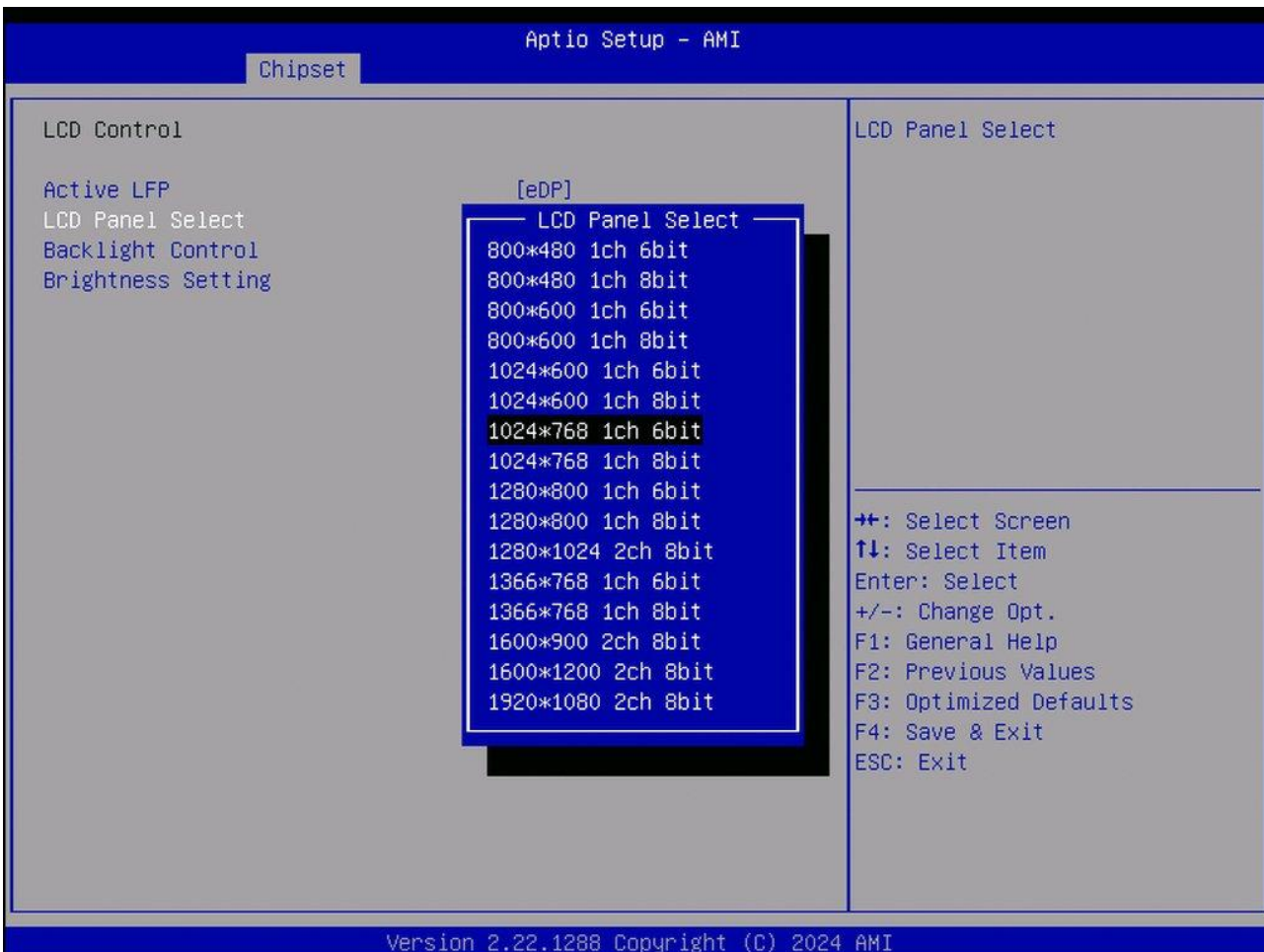

### 3.5.3.3 Backlight Control

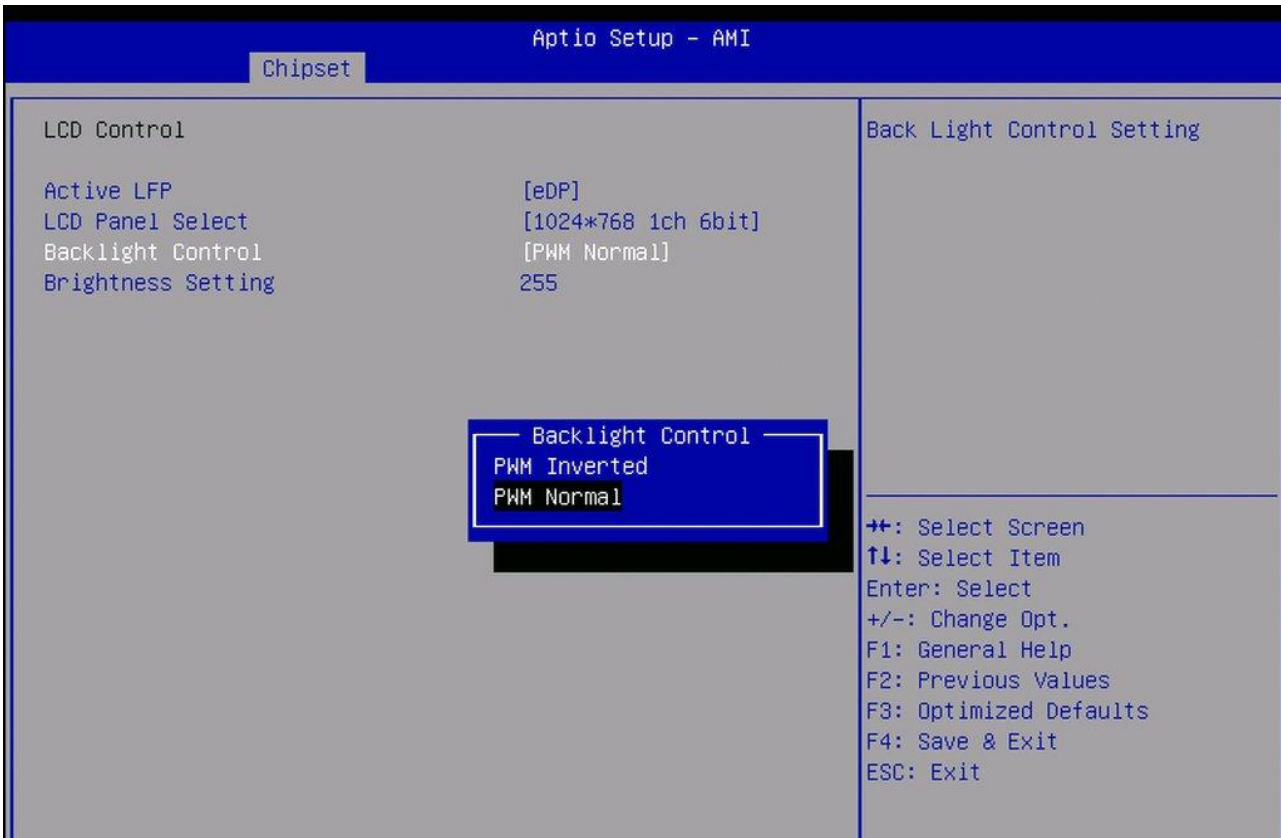

### 3.5.3.4 Brightness Setting

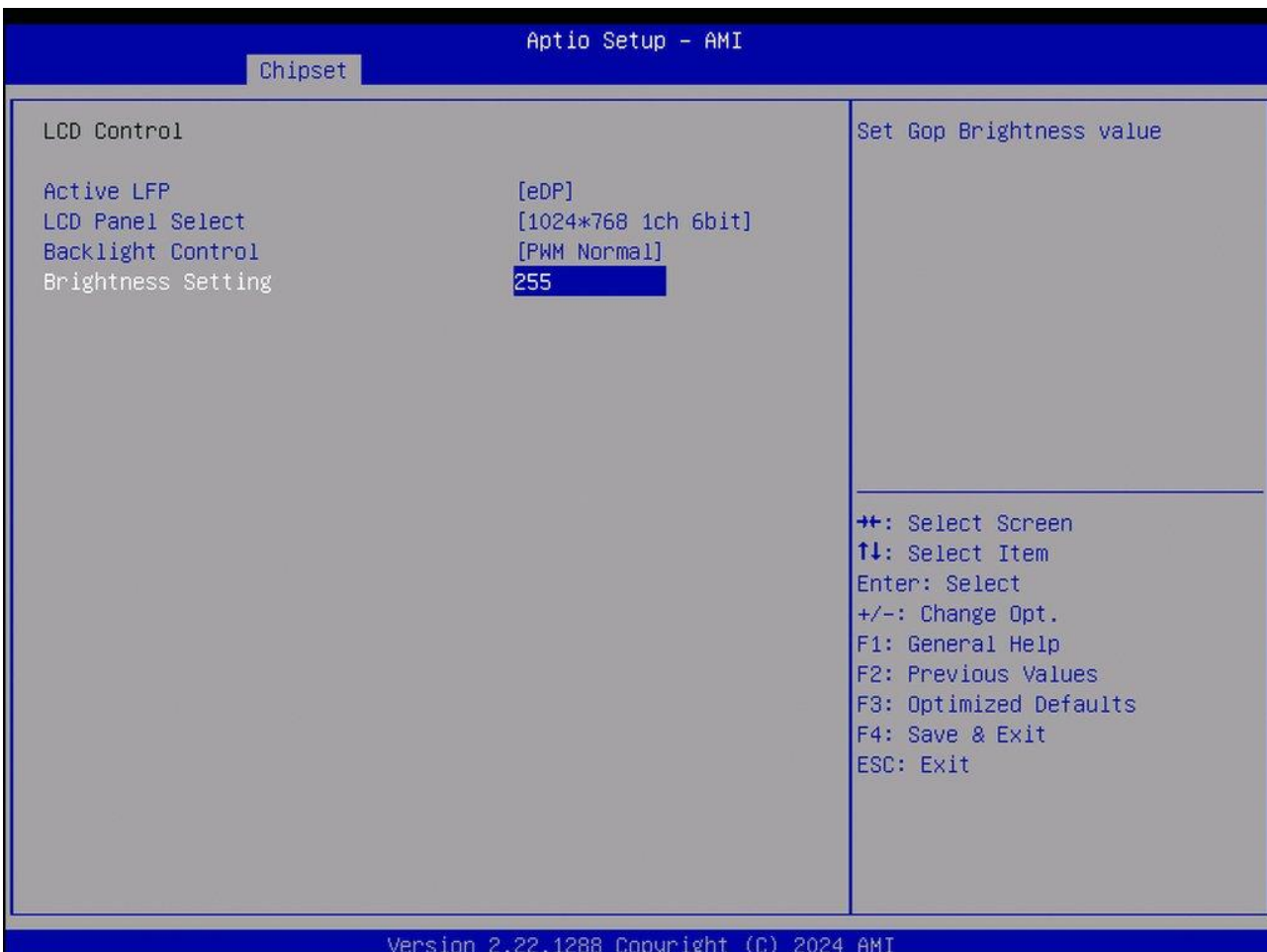

### 3.6 Security Settings

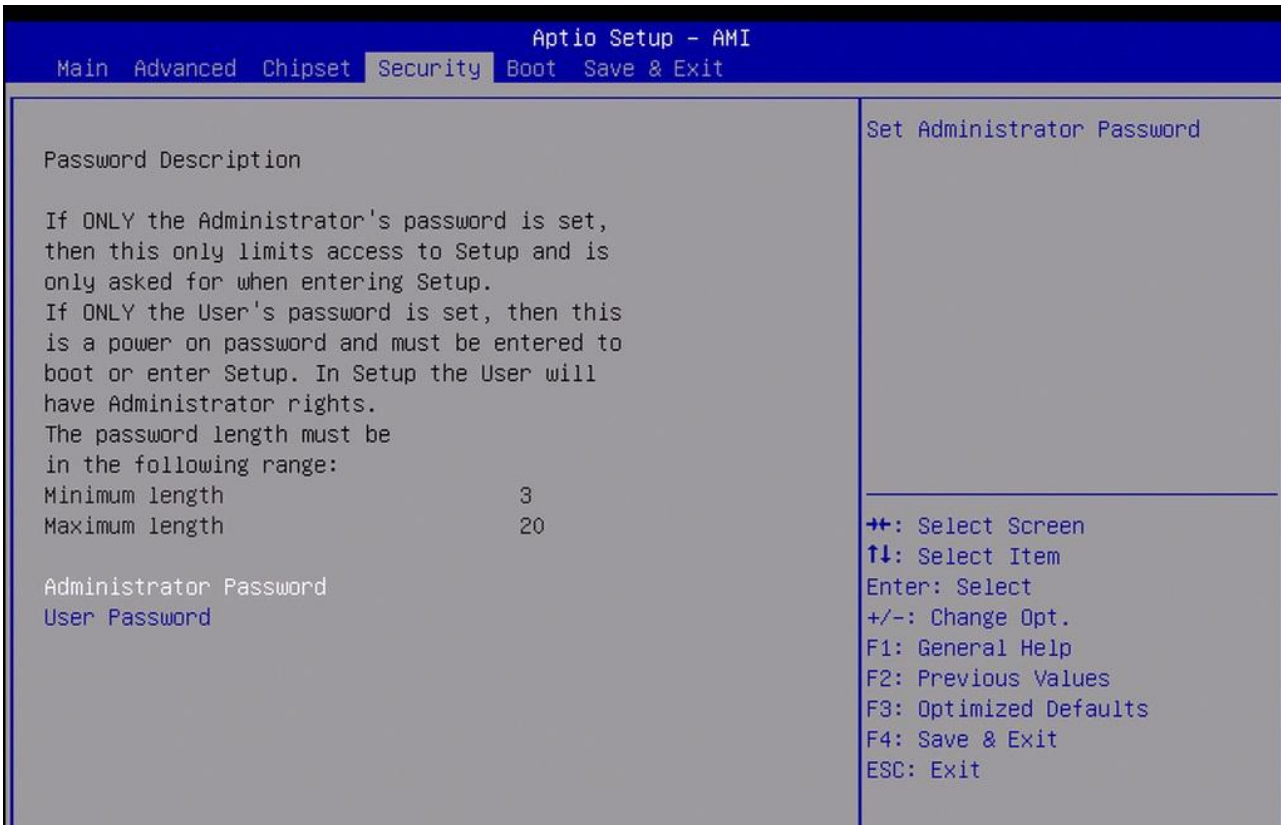

#### 3.6.1 Administrator Password

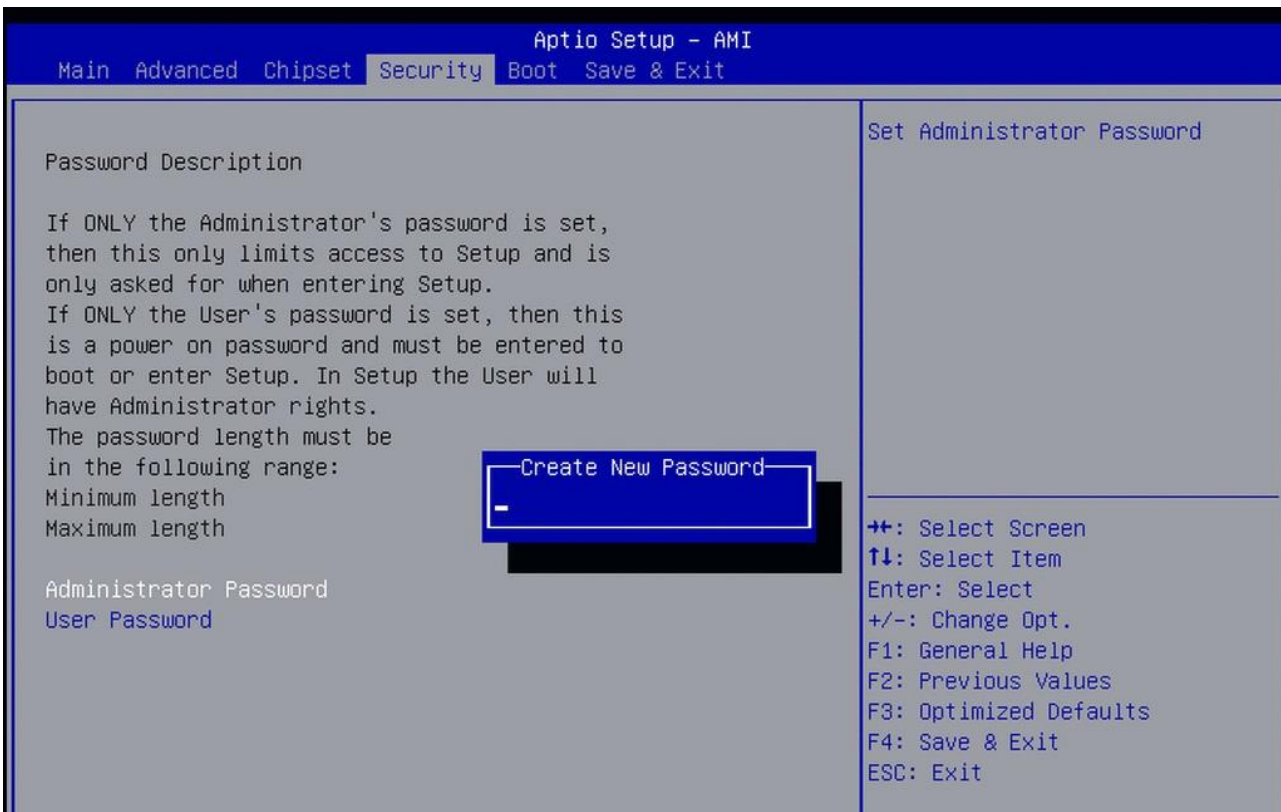

### 3.6.2 User Password

The screenshot shows the 'Aptio Setup - AMI' interface with the 'Security' tab selected. The 'Set User Password' screen is active. On the left, there is a 'Password Description' section explaining the difference between Administrator and User passwords and their lengths. Below this, there are fields for 'Administrator Password' and 'User Password'. A 'Create New Password' dialog box is open, showing a single dash character. On the right, a list of navigation keys is provided: ++ for Select Screen, ↑↓ for Select Item, Enter for Select, +/- for Change Opt., F1 for General Help, F2 for Previous Values, F3 for Optimized Defaults, F4 for Save & Exit, and ESC for Exit.

**Aptio Setup - AMI**  
Main Advanced Chipset **Security** Boot Save & Exit

Set User Password

Password Description

If ONLY the Administrator's password is set, then this only limits access to Setup and is only asked for when entering Setup.  
If ONLY the User's password is set, then this is a power on password and must be entered to boot or enter Setup. In Setup the User will have Administrator rights.  
The password length must be in the following range:  
Minimum length  
Maximum length

Administrator Password  
User Password

Create New Password

++: Select Screen  
↑↓: Select Item  
Enter: Select  
+/-: Change Opt.  
F1: General Help  
F2: Previous Values  
F3: Optimized Defaults  
F4: Save & Exit  
ESC: Exit

### 3.7 Boot Settings

The screenshot shows the 'Aptio Setup - AMI' interface with the 'Boot' tab selected. The 'Boot Configuration' screen is active. It lists several settings: 'Setup Prompt Timeout' set to 3, 'Bootup NumLock State' set to [On], 'Quiet Boot' set to [Disabled], and 'Fast Boot' set to [Disabled]. On the right, there is a description of the 'Number of seconds to wait for setup activation key' and a list of navigation keys: ++ for Select Screen, ↑↓ for Select Item, Enter for Select, +/- for Change Opt., F1 for General Help, F2 for Previous Values, F3 for Optimized Defaults, F4 for Save & Exit, and ESC for Exit.

**Aptio Setup - AMI**  
Main Advanced Chipset Security **Boot** Save & Exit

Boot Configuration

Setup Prompt Timeout 3  
Bootup NumLock State [On]  
Quiet Boot [Disabled]

Boot Option Priorities

Fast Boot [Disabled]

Number of seconds to wait for setup activation key.  
65535(0xFFFF) means indefinite waiting.

++: Select Screen  
↑↓: Select Item  
Enter: Select  
+/-: Change Opt.  
F1: General Help  
F2: Previous Values  
F3: Optimized Defaults  
F4: Save & Exit  
ESC: Exit

### 3.8 Save & Exit Settings

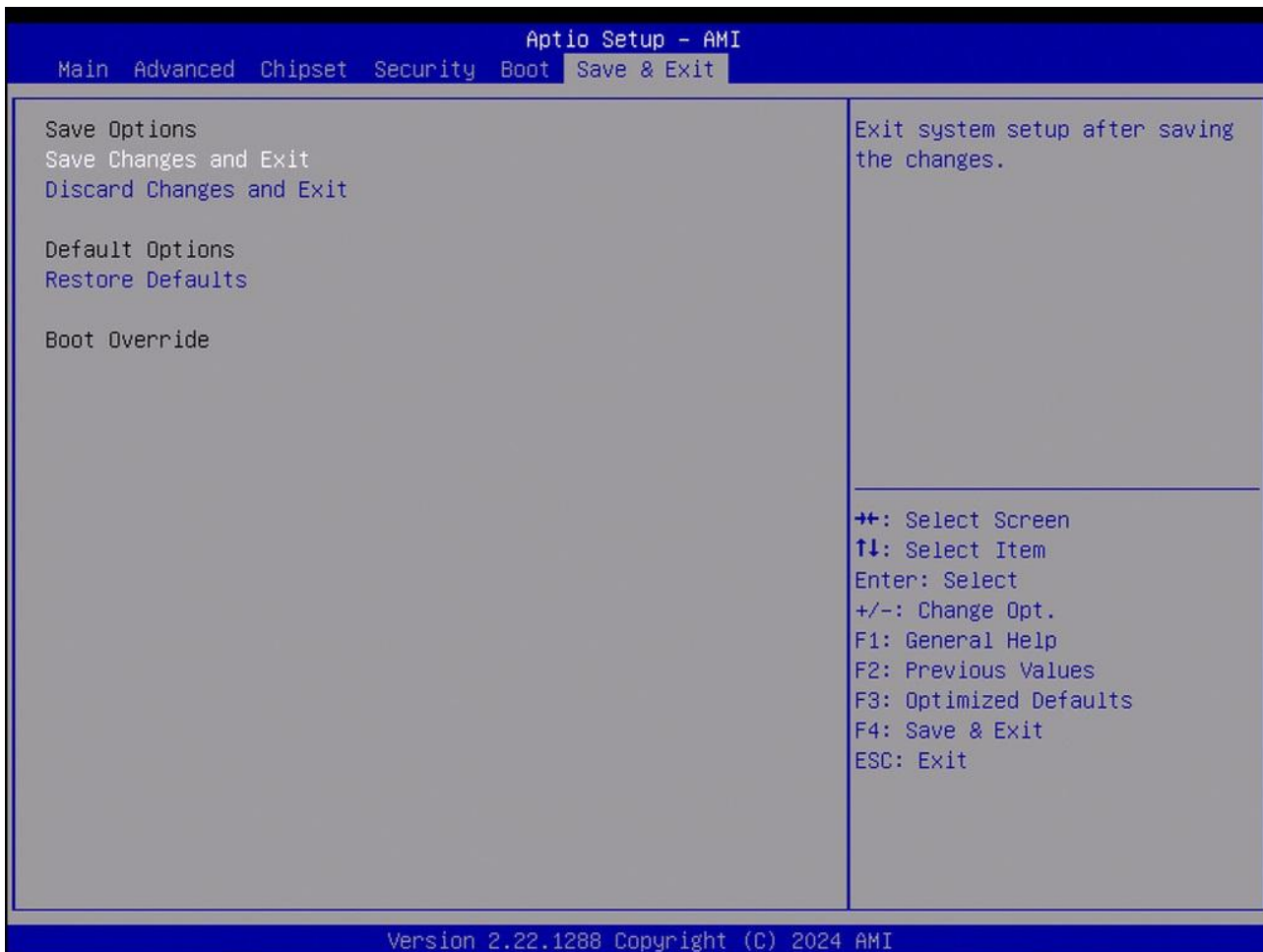

### 3.9 Secure Boot Keys

How to Enroll Secure Boot Keys (PK, KEK, db) in BIOS/UEFI.

This document explains how to import Secure Boot keys into a UEFI firmware (BIOS). Procedures may vary slightly depending on the motherboard vendor, but the overall process is the same across most platforms supporting UEFI Secure Boot.

0. You must first obtain the Secure Keys (PK, KEK, db) from Microsoft.

After that, prepare a FAT32-formatted USB drive, UEFI firmware typically only reads key files from FAT32 file systems. Copy your secure keys (PK, KEK, db) to the root directory of the USB drive.

1. When boot up the unit, press DEL on the keyboard. Enter the BIOS menu and select the option shown in the image below.

Path: Security/Secure Boot Mode, and select "Custom"

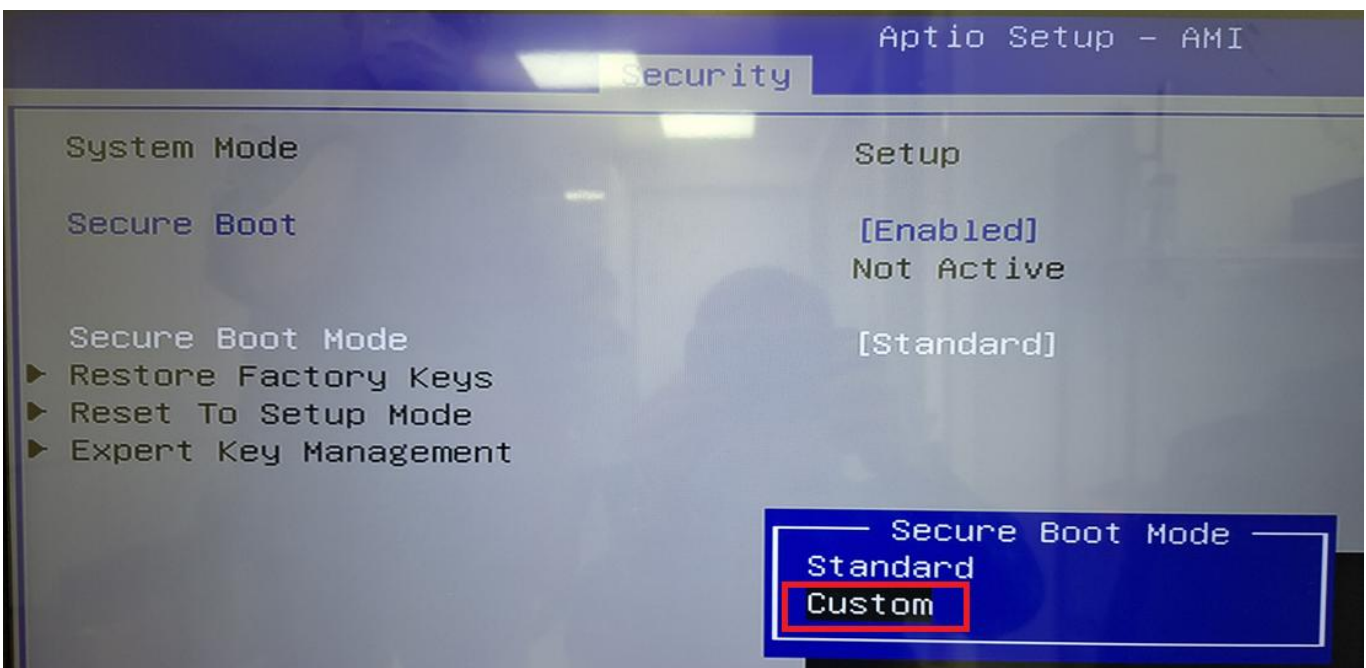
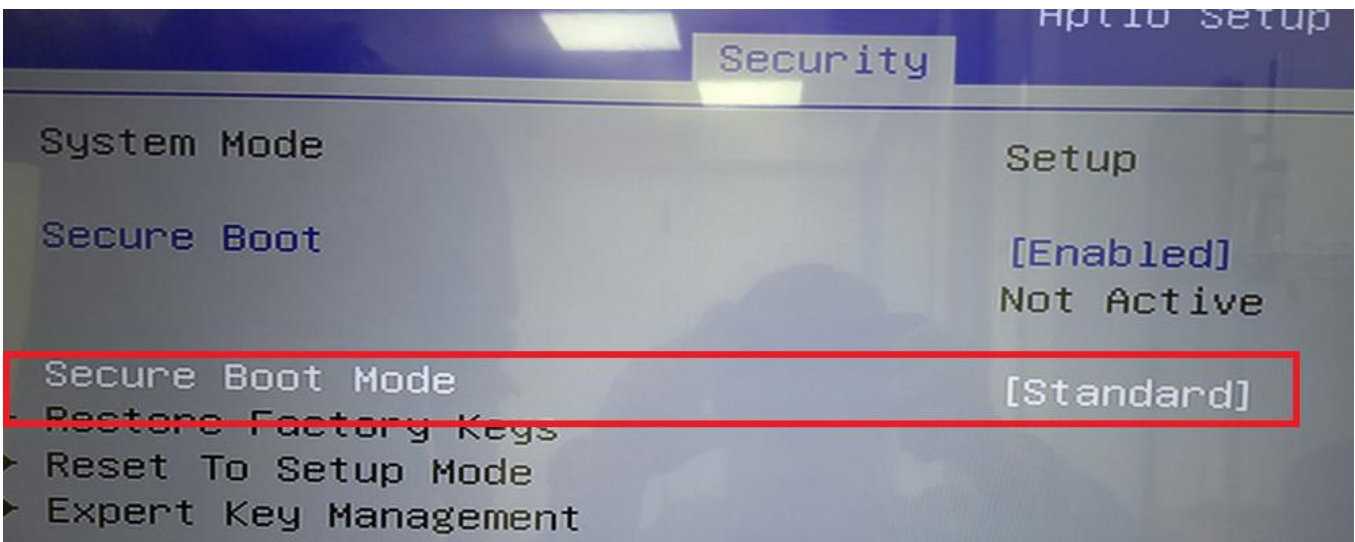

2. Then select “Expert Key Management”

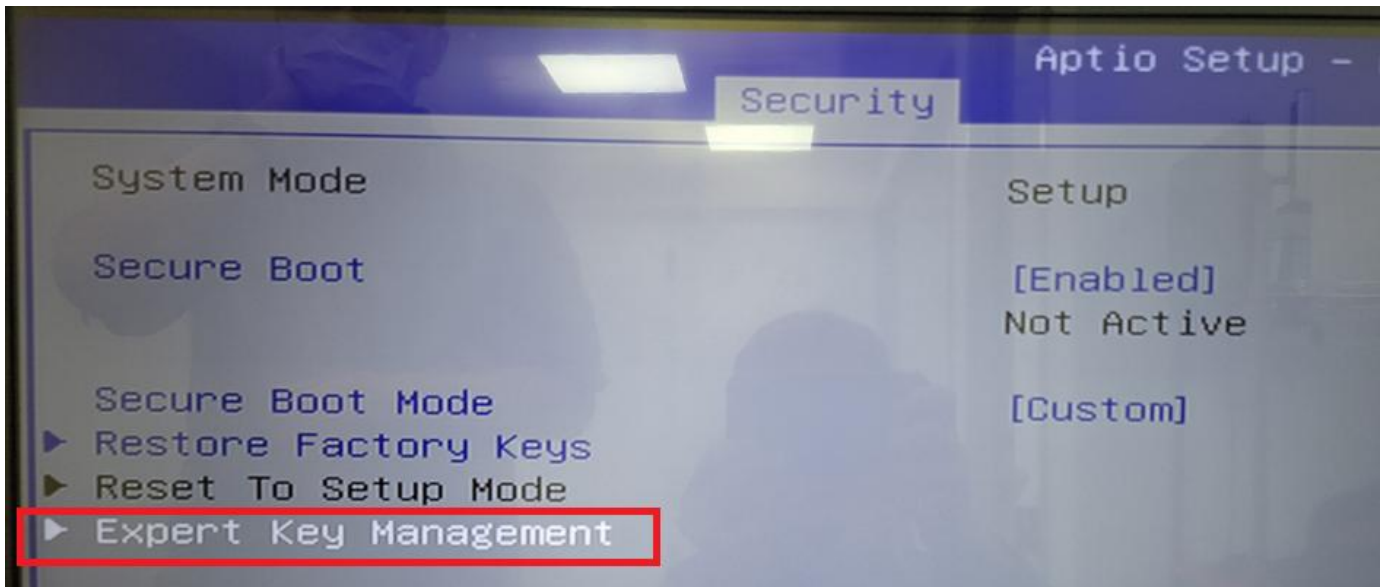

3. Select “Platform Key (PK)”, enter

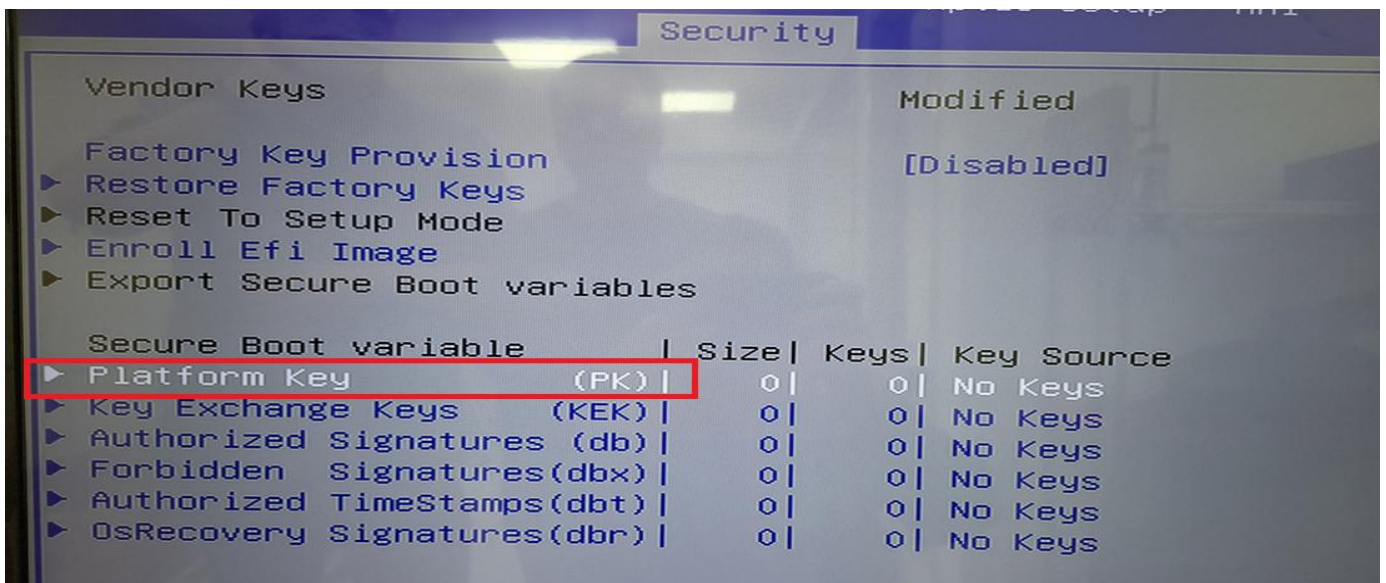

Select “Update”

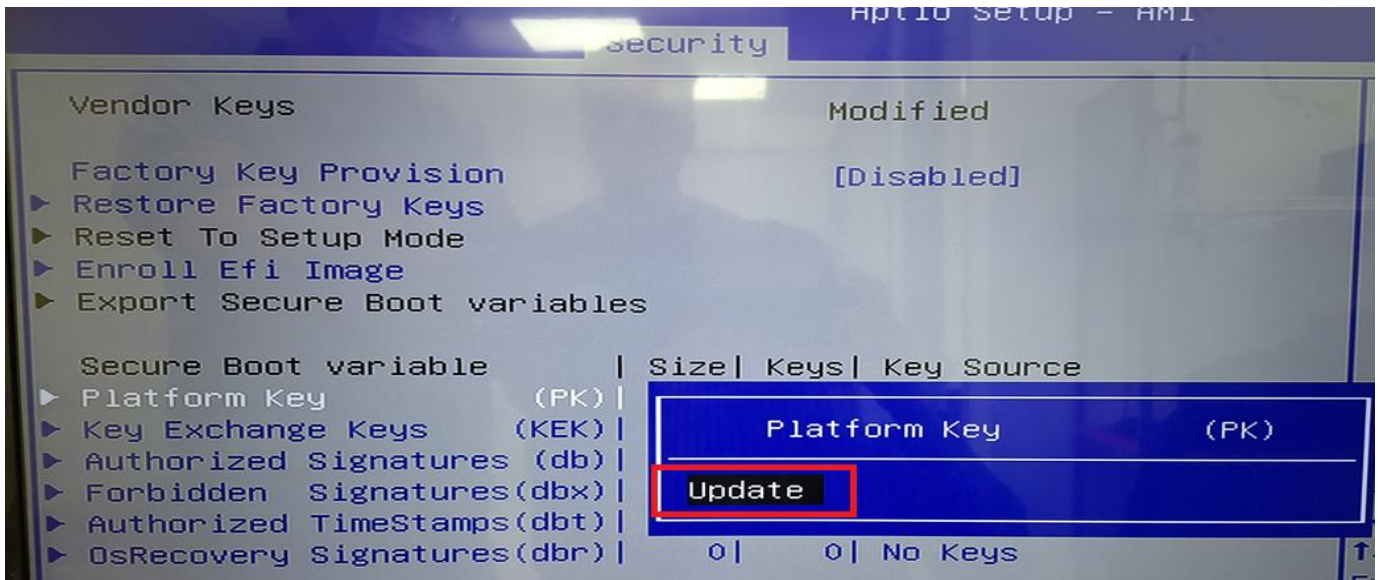

Select "No"

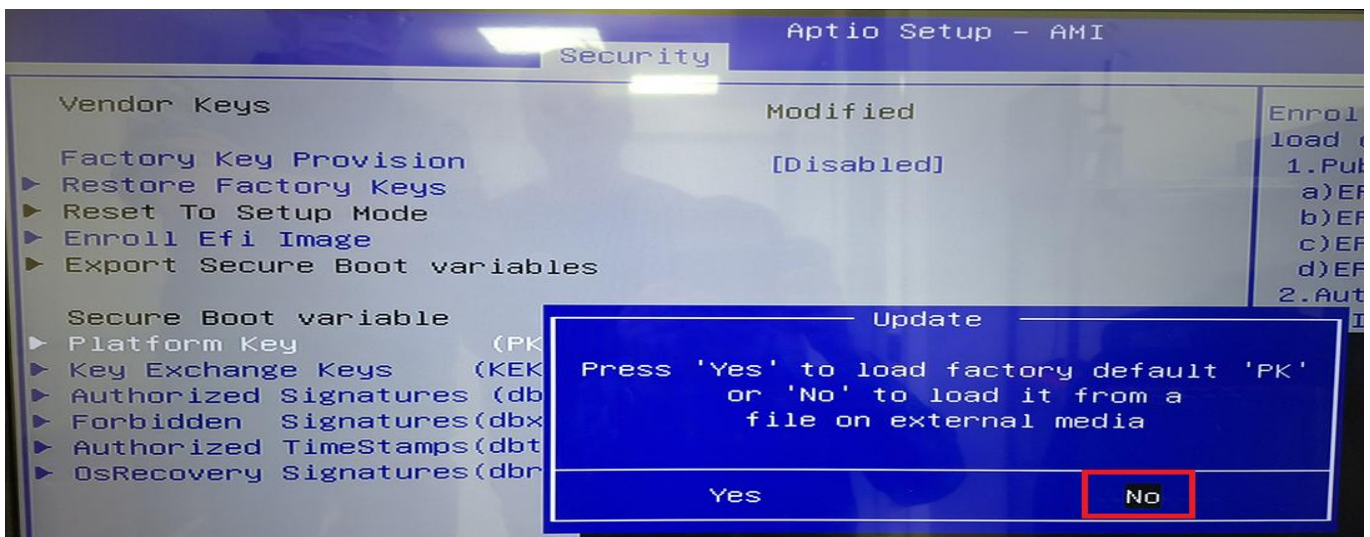

Find your USB drive to select your Keys (PK).

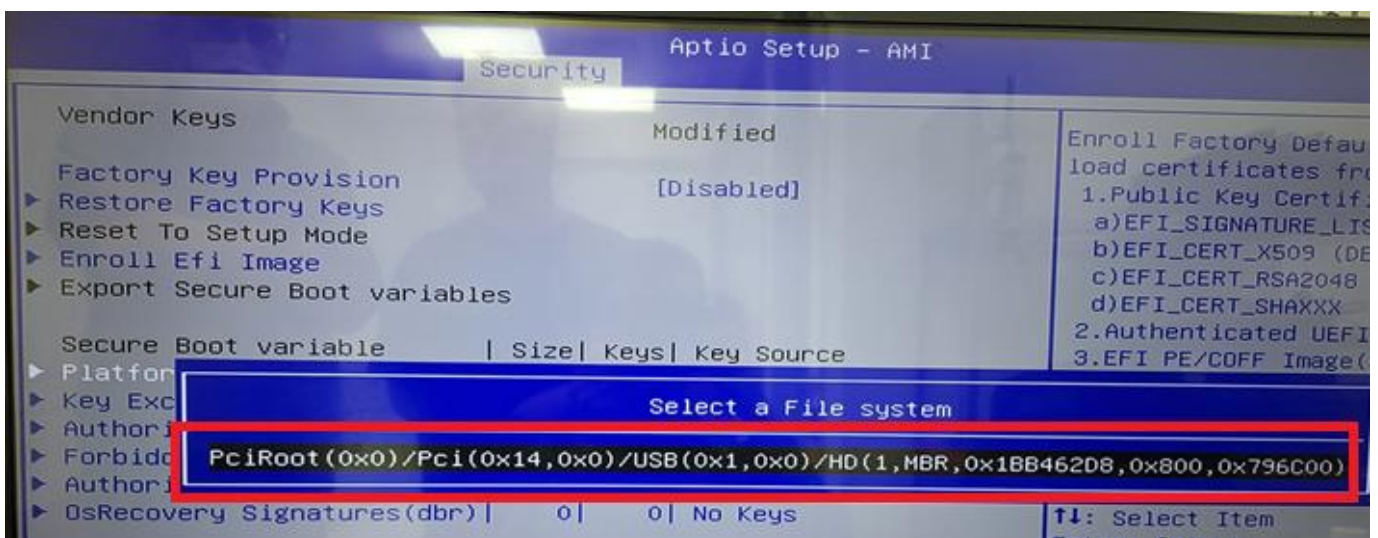

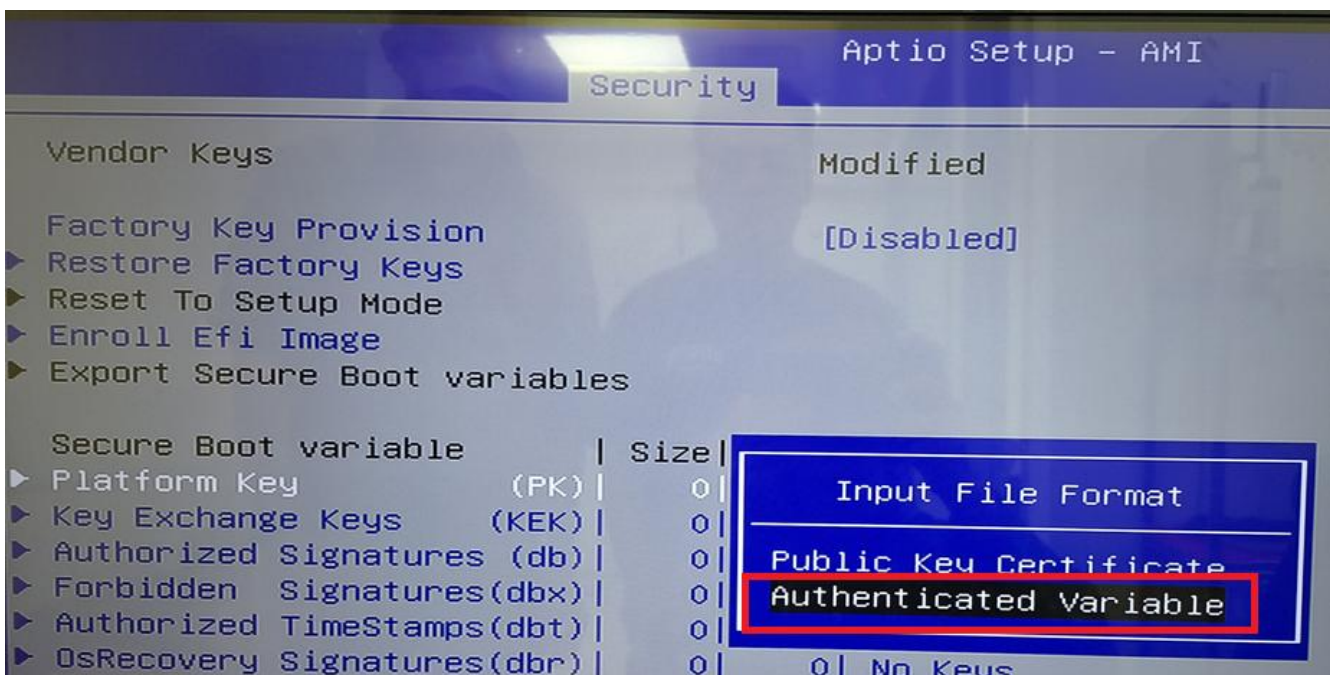
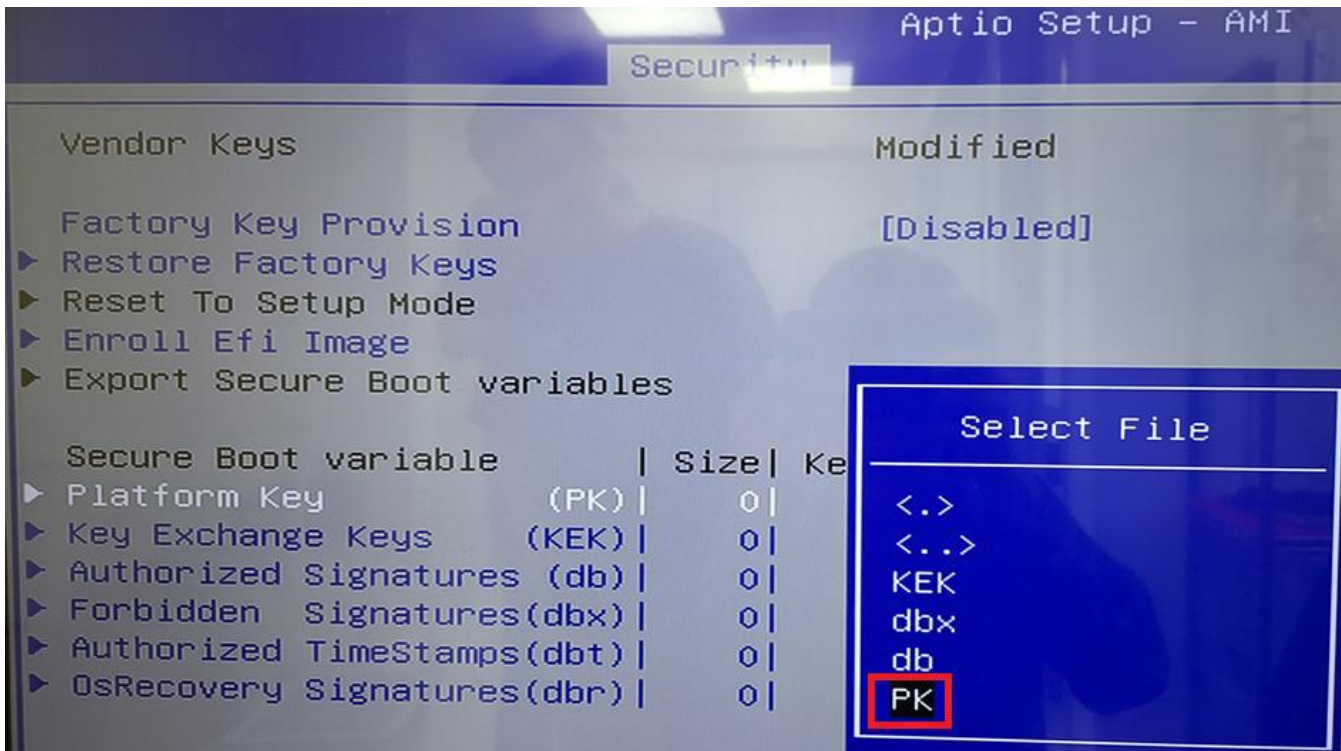

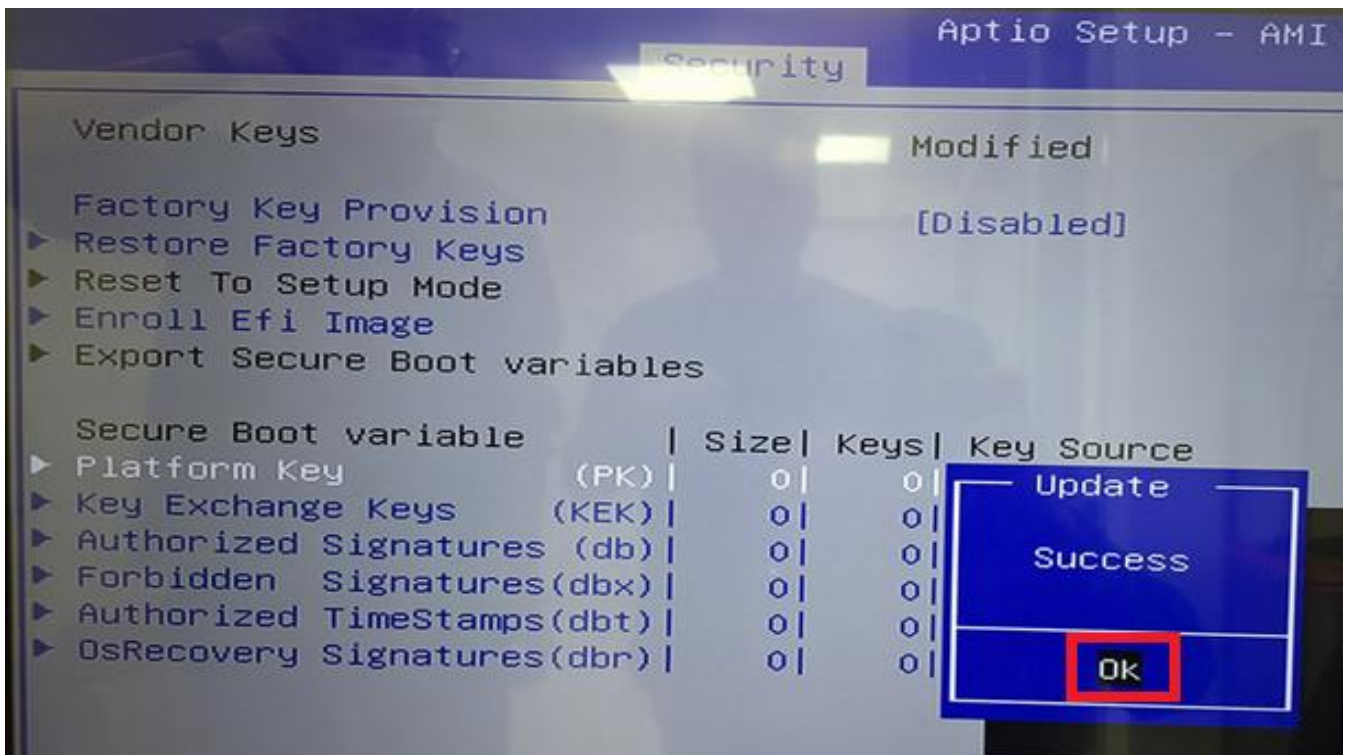
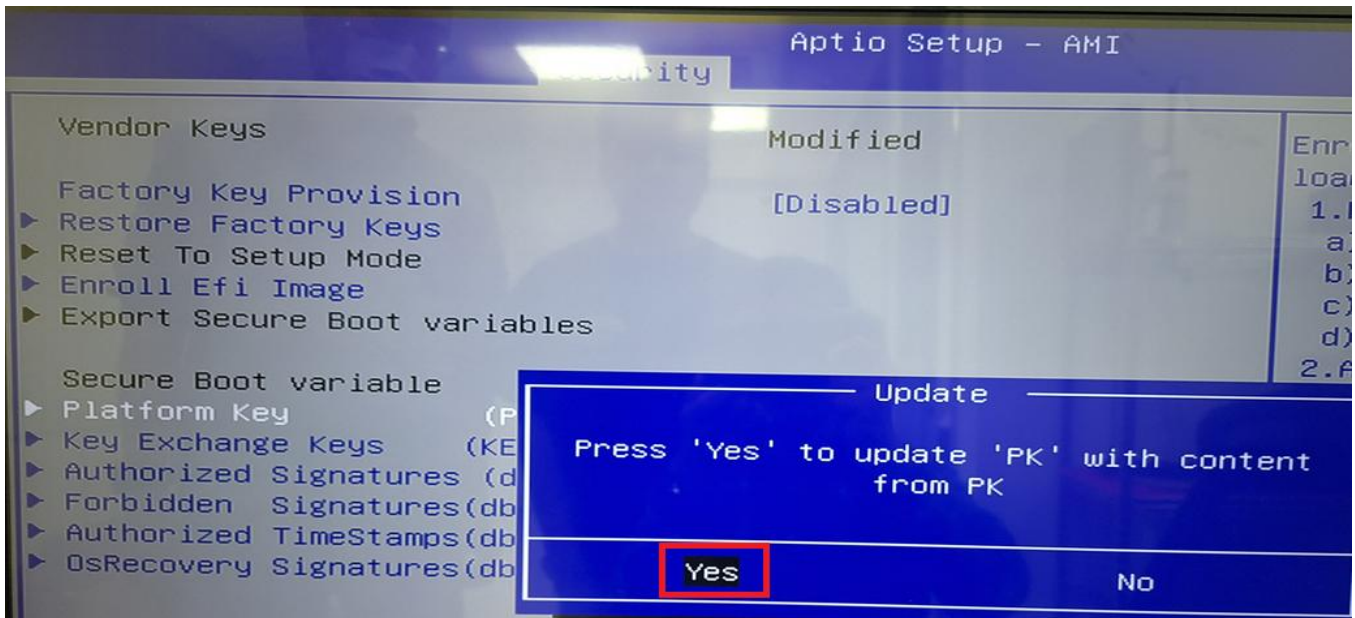

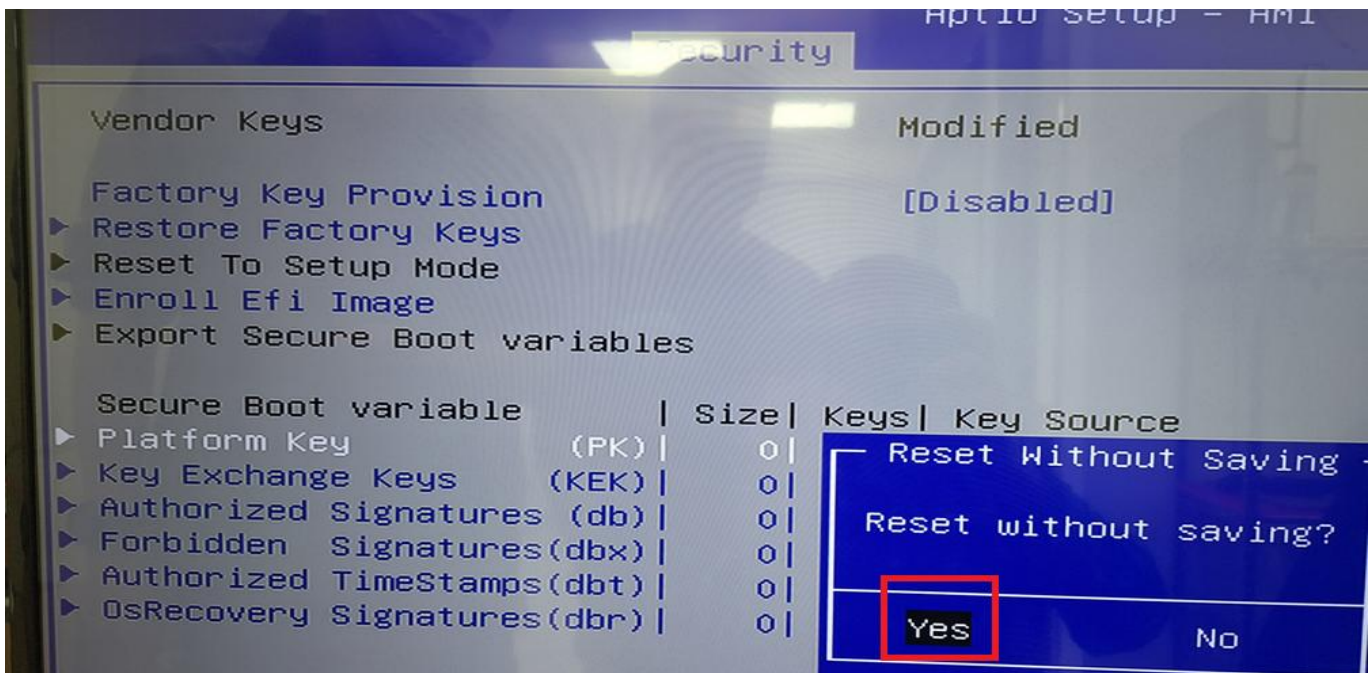

The image below shows that the Platform Key (PK) has already been successfully enrolled.

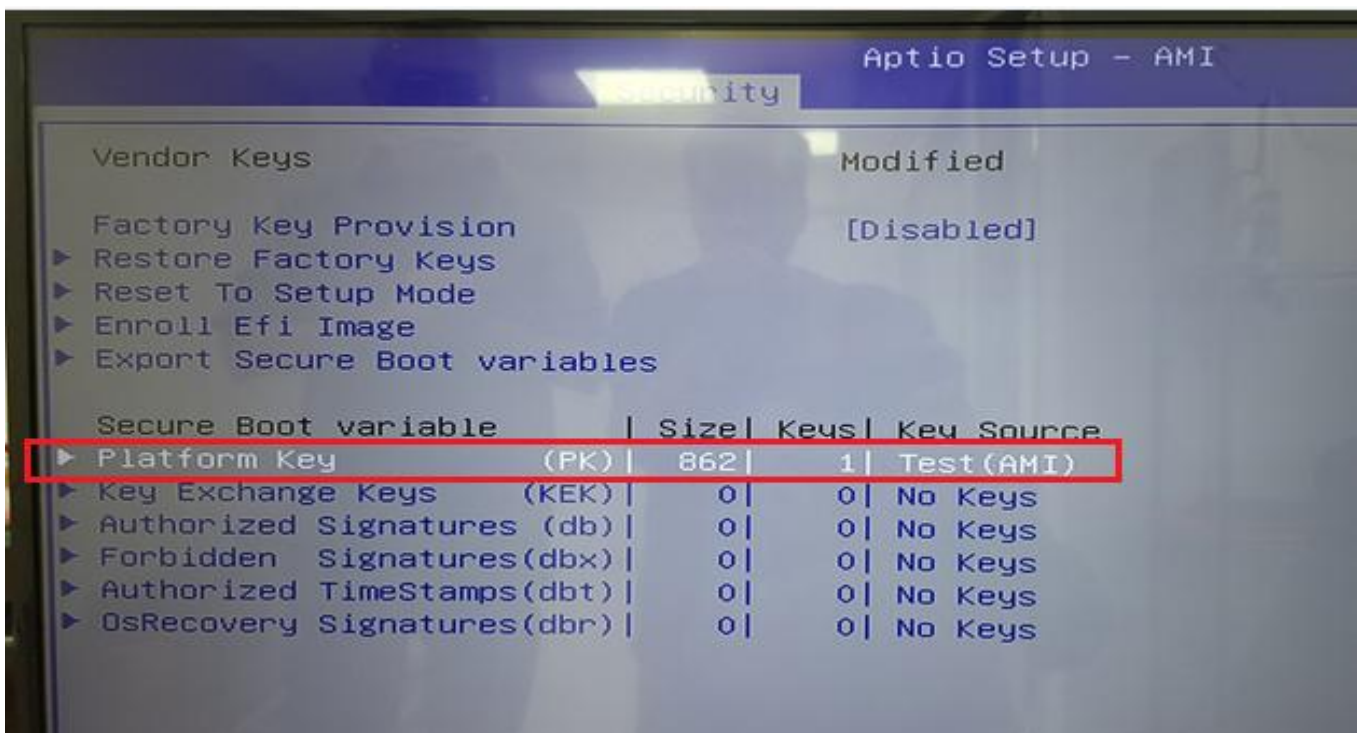

4. Select "Key Exchange Keys (KEK)", enter

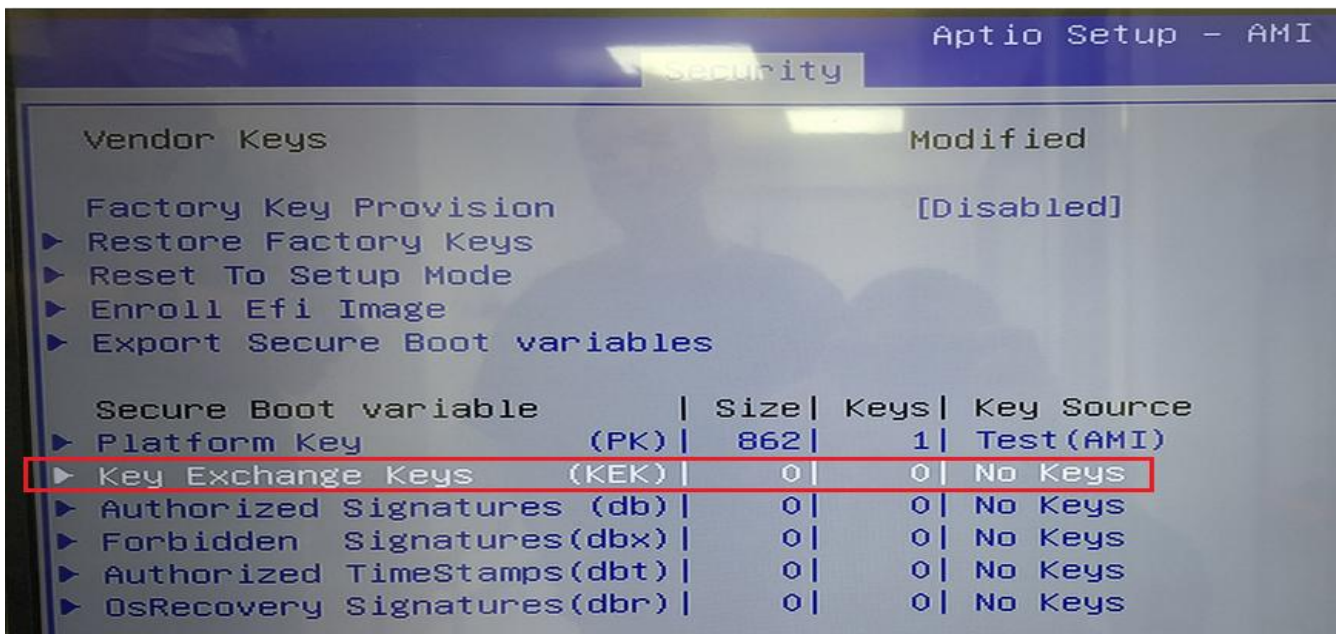

### Select "Update"

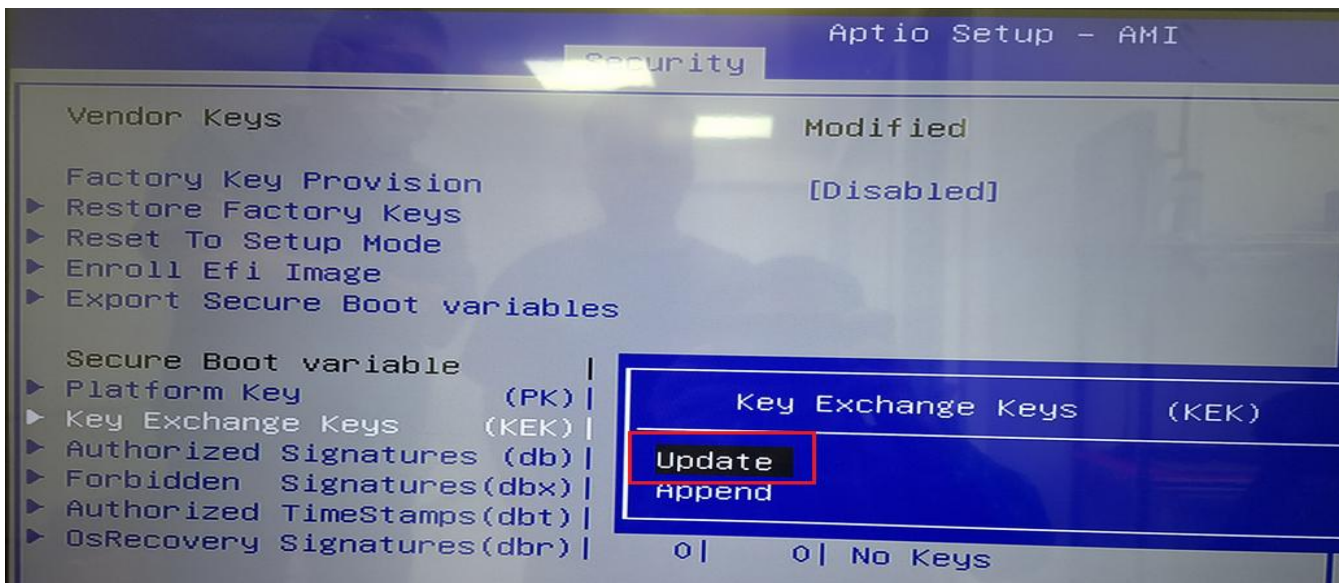

### Select "No"

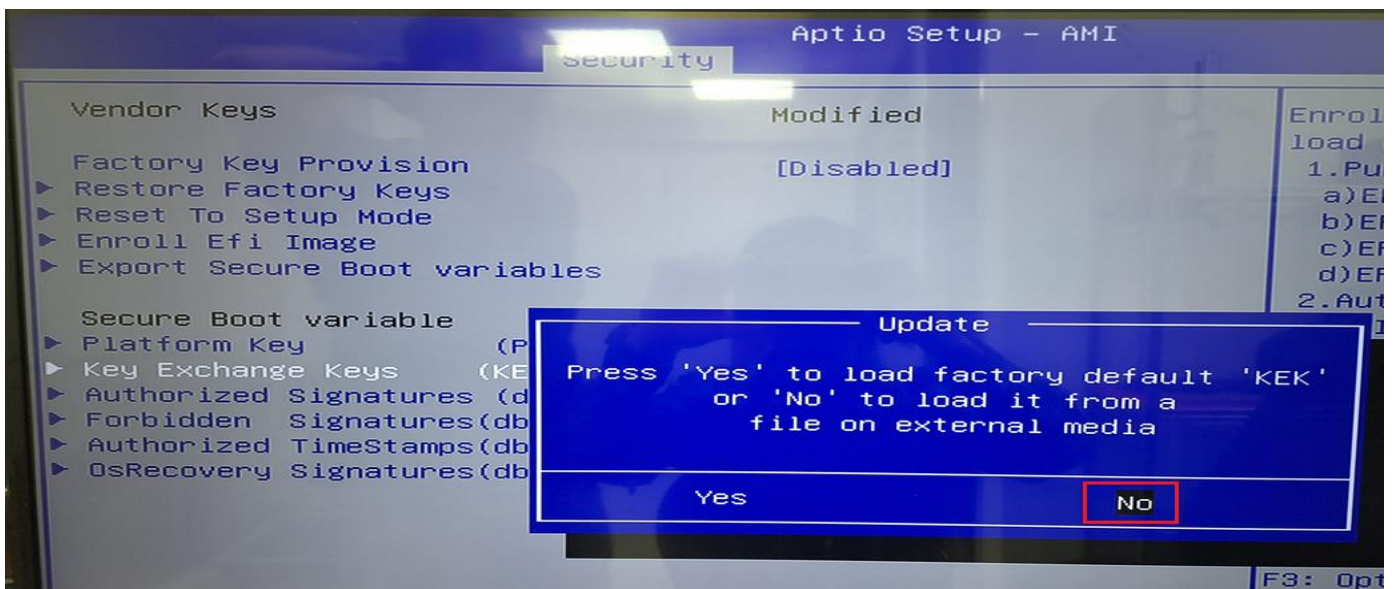

**Find your USB drive to select your Key Exchange Keys (KEK).**

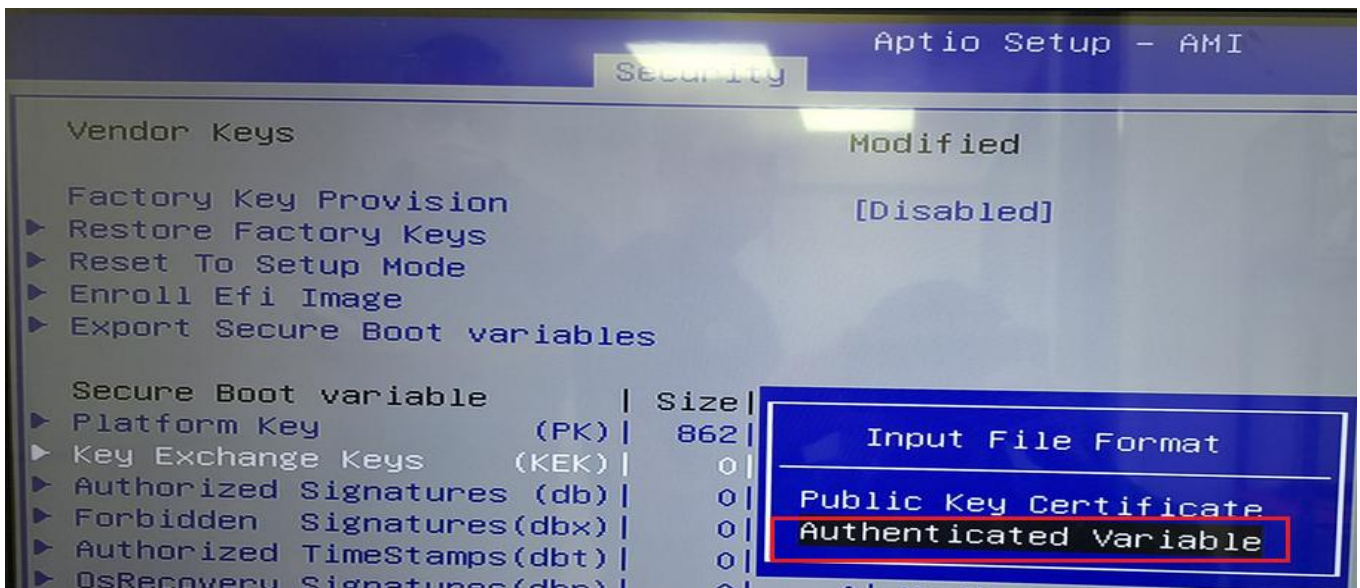
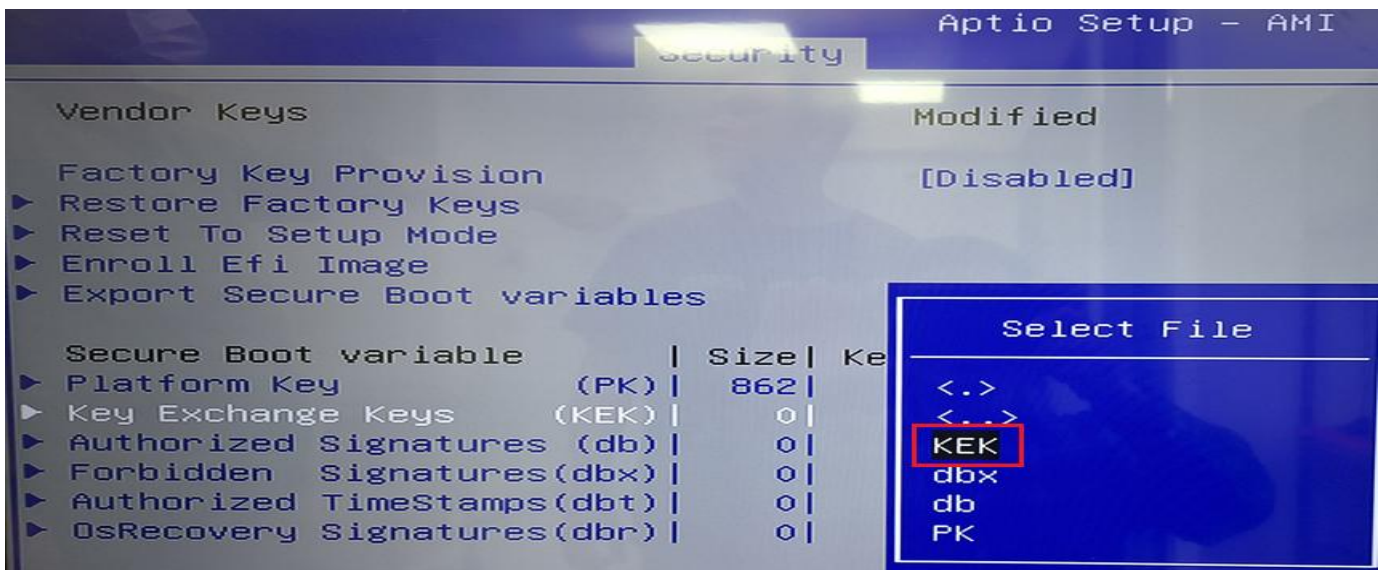
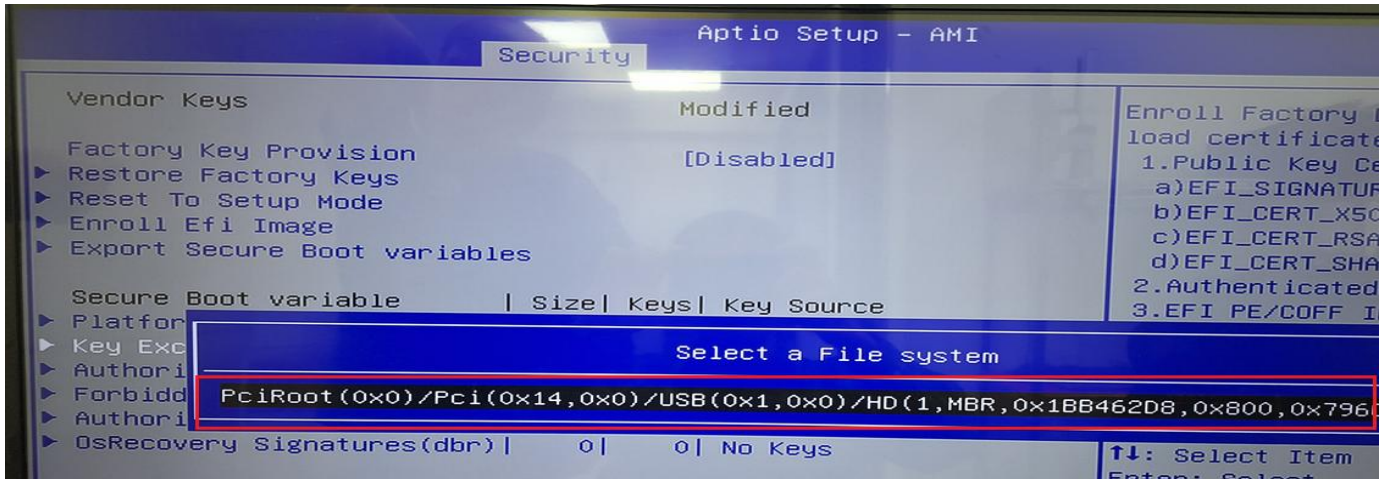

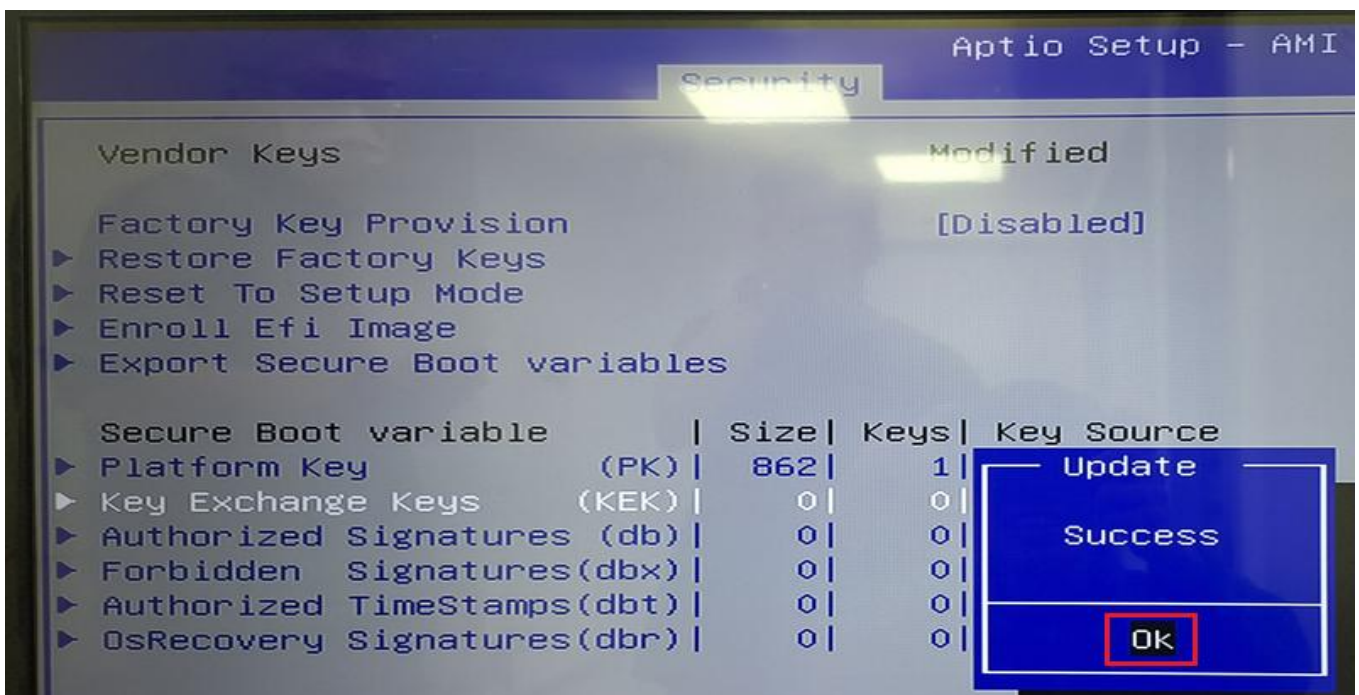
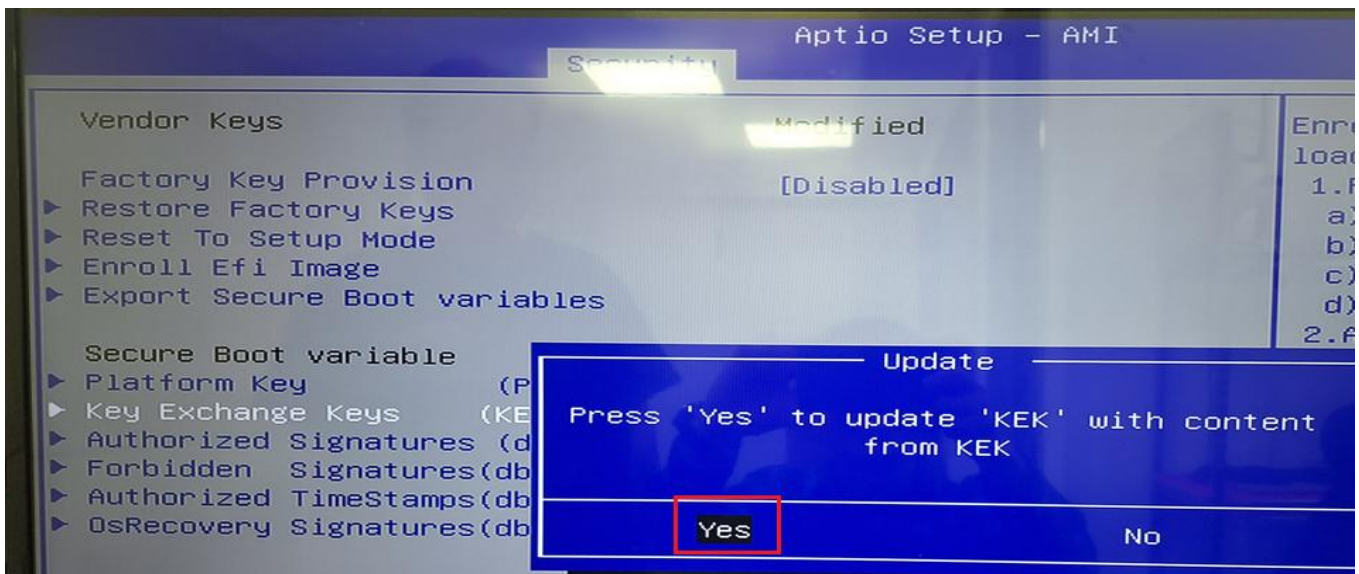

The image below shows that the Key Exchange Keys (KEK) has already been successfully enrolled.

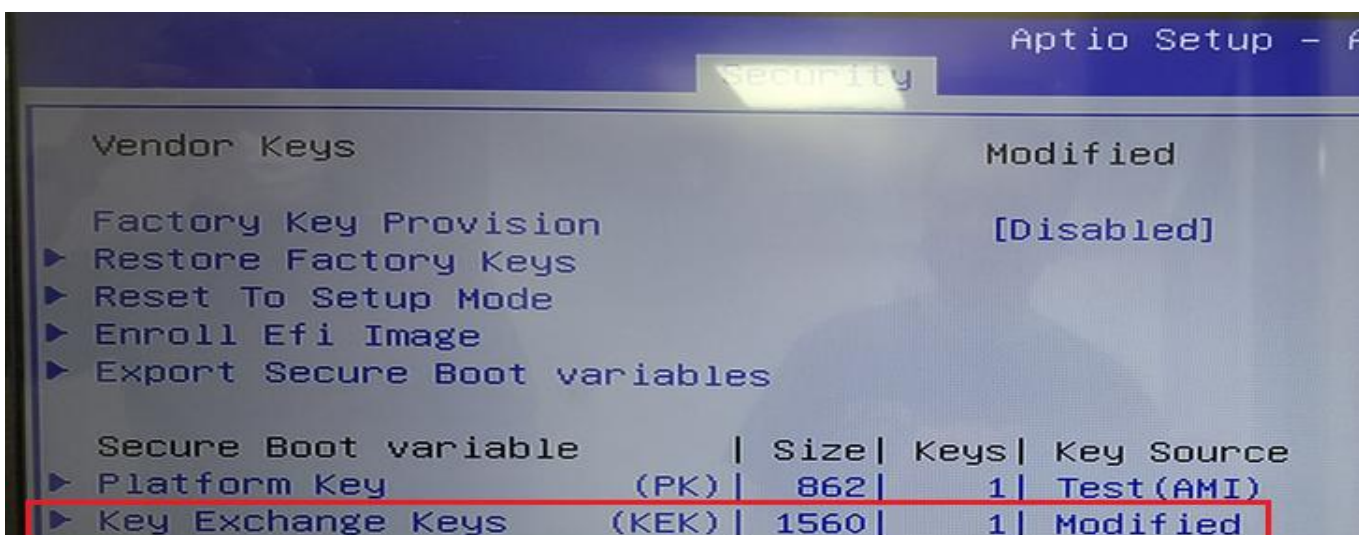

5. Select “Authorized Signatures (db)” , enter

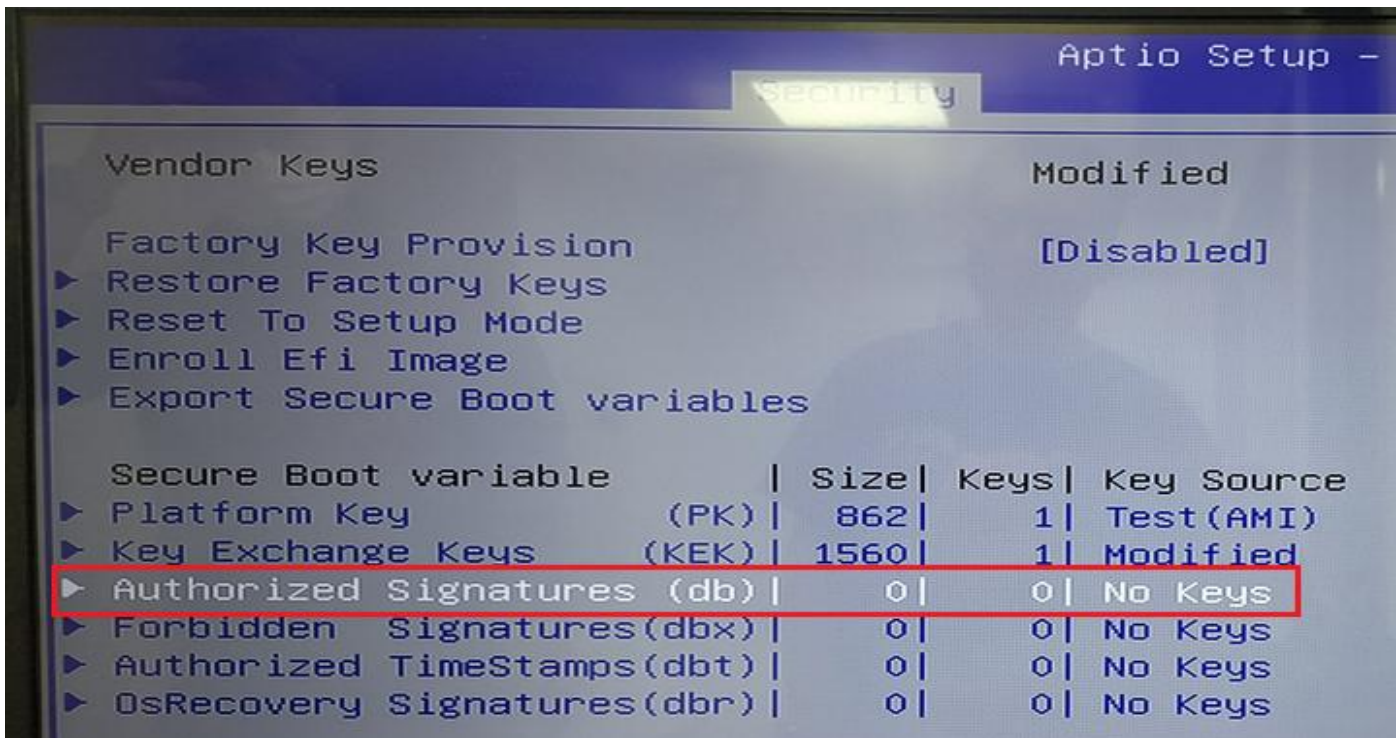

Select “Update”

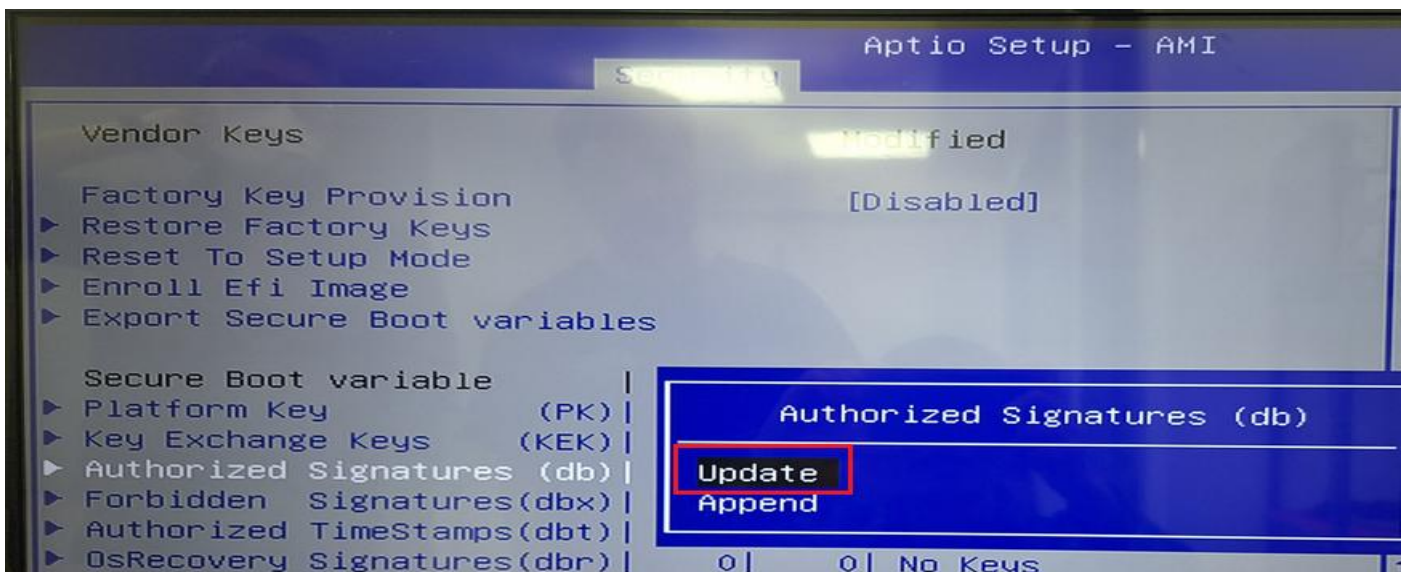

Select “No”

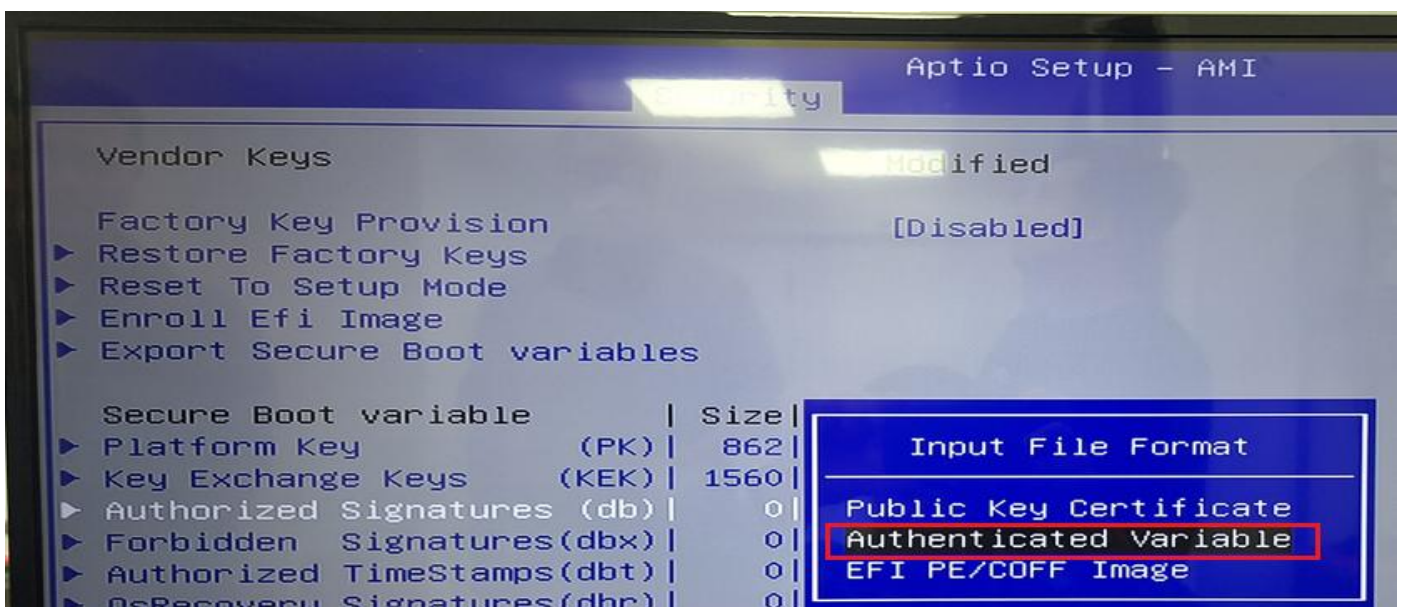
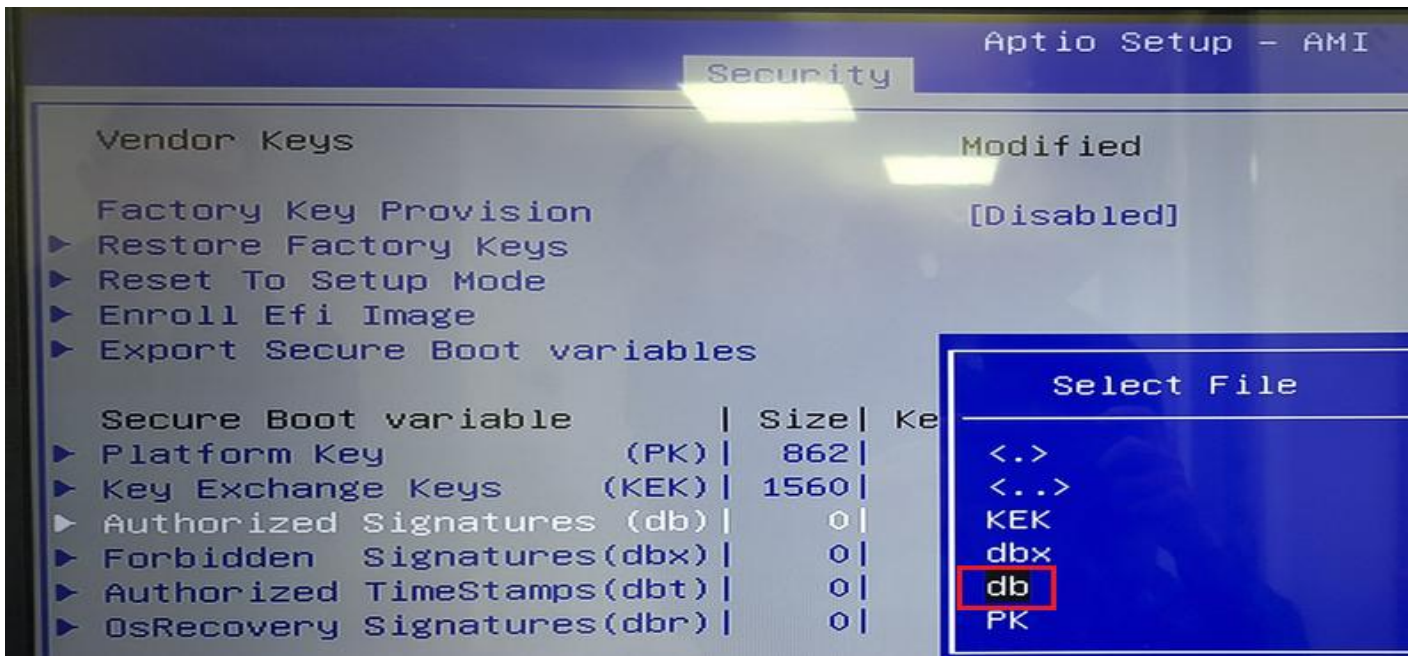
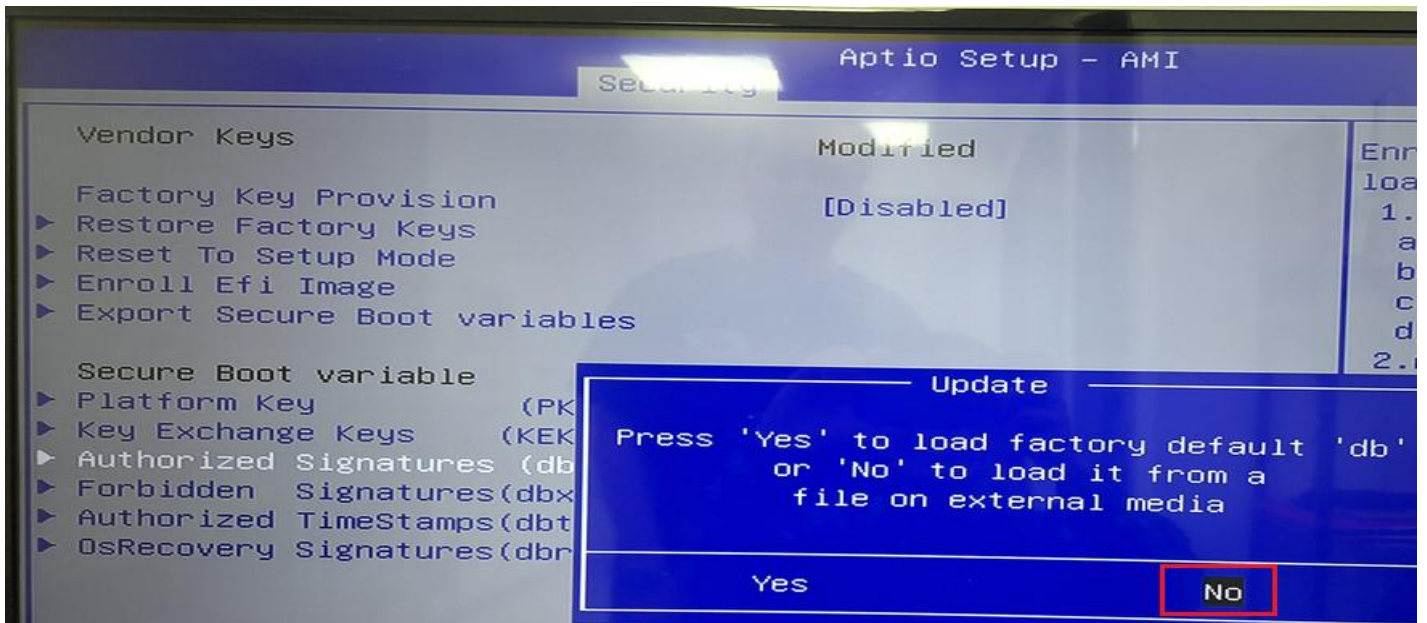

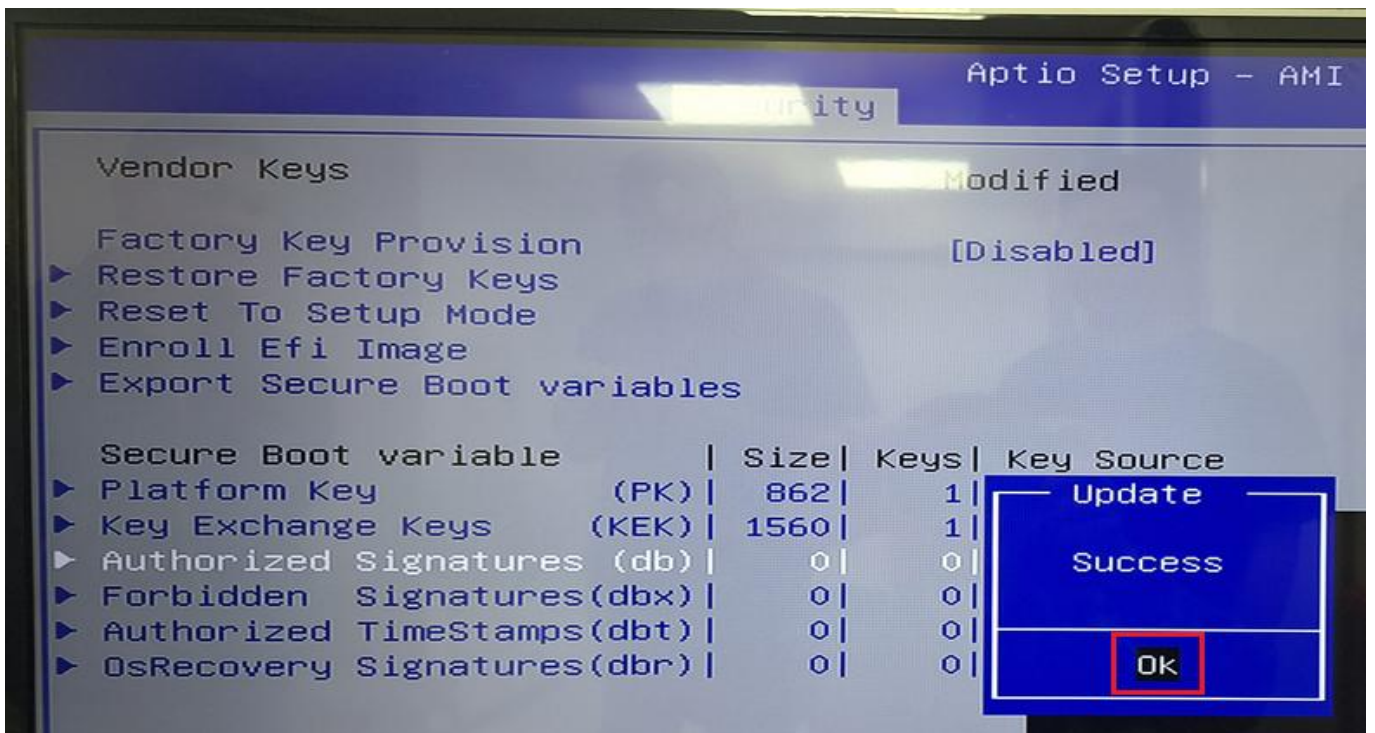
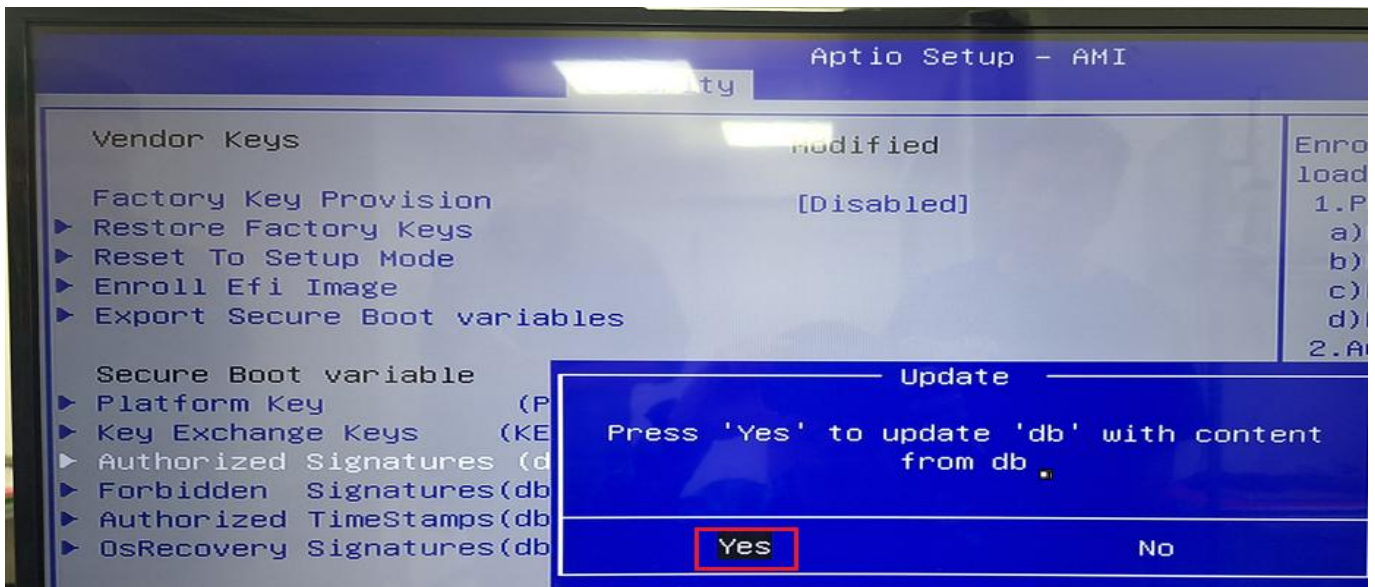

Once the above steps are completed, the key enrollment process is finished.

6. To verify that Secure Boot is functioning properly in the Windows environment. Search "System information" in Windows.

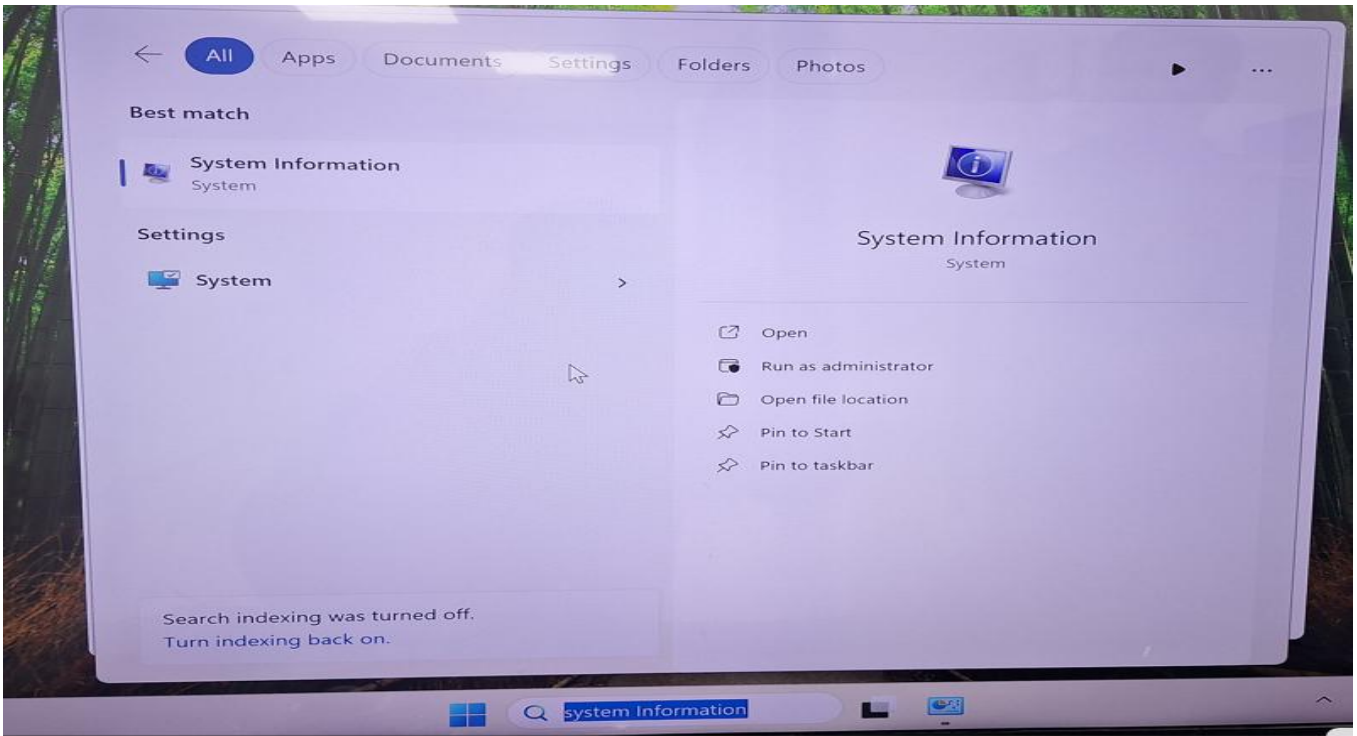

Right-click, and then select “Run as administrator”

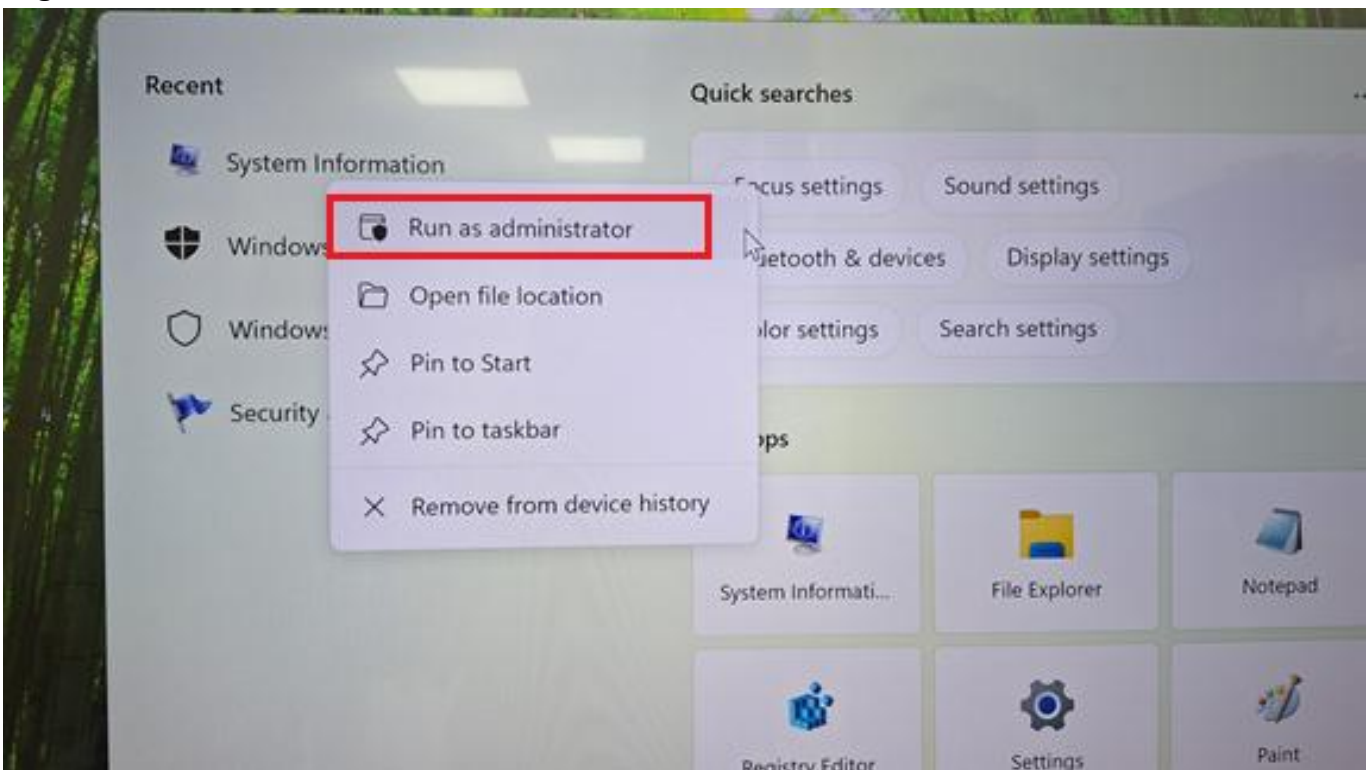

Verify that Secure Boot State is shown as On, and PCR7 Configuration is listed as Binding Possible.

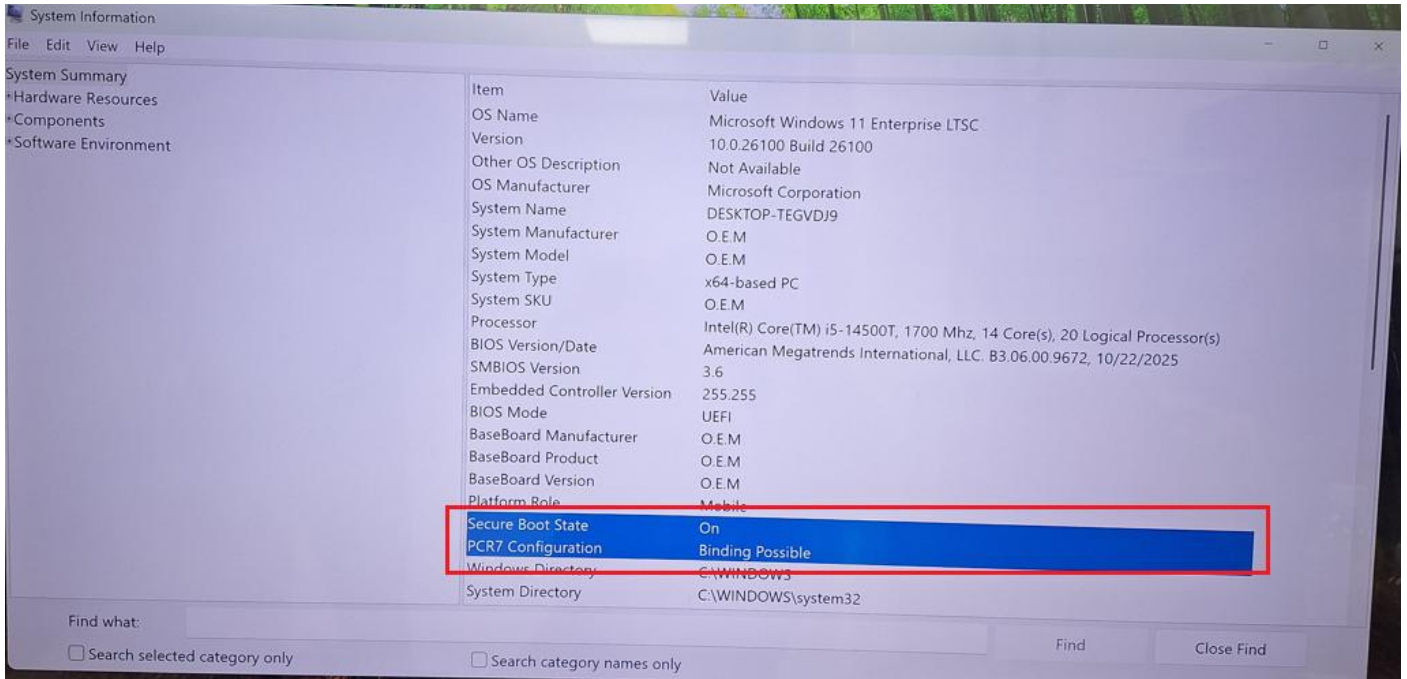

**Thank you for going through this instruction. Following it will help you complete the setup smoothly**



## 4.1 Intel Chipset

To install the Intel chipset driver, please follow the steps below.

Step 1. Here is welcome page. Please make sure you save and exit all programs before install. Click **Next**.

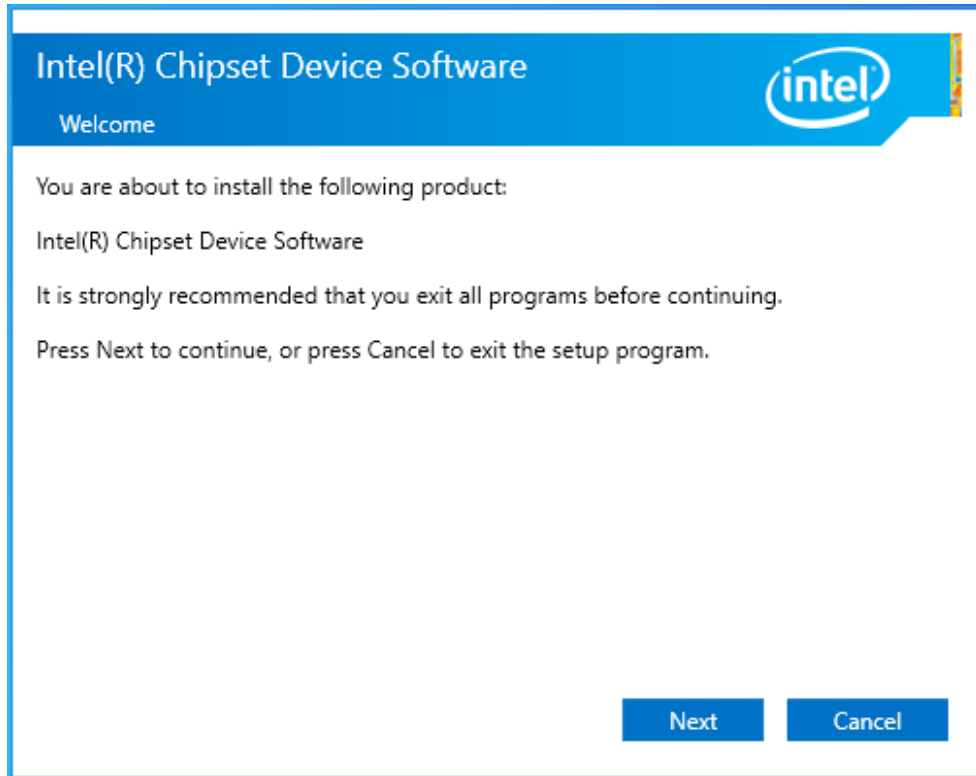

Step 2. Read the license agreement. Click **Accept** to accept all of the terms of the license agreement.



Step 3. Click **Install** to begin the installation.

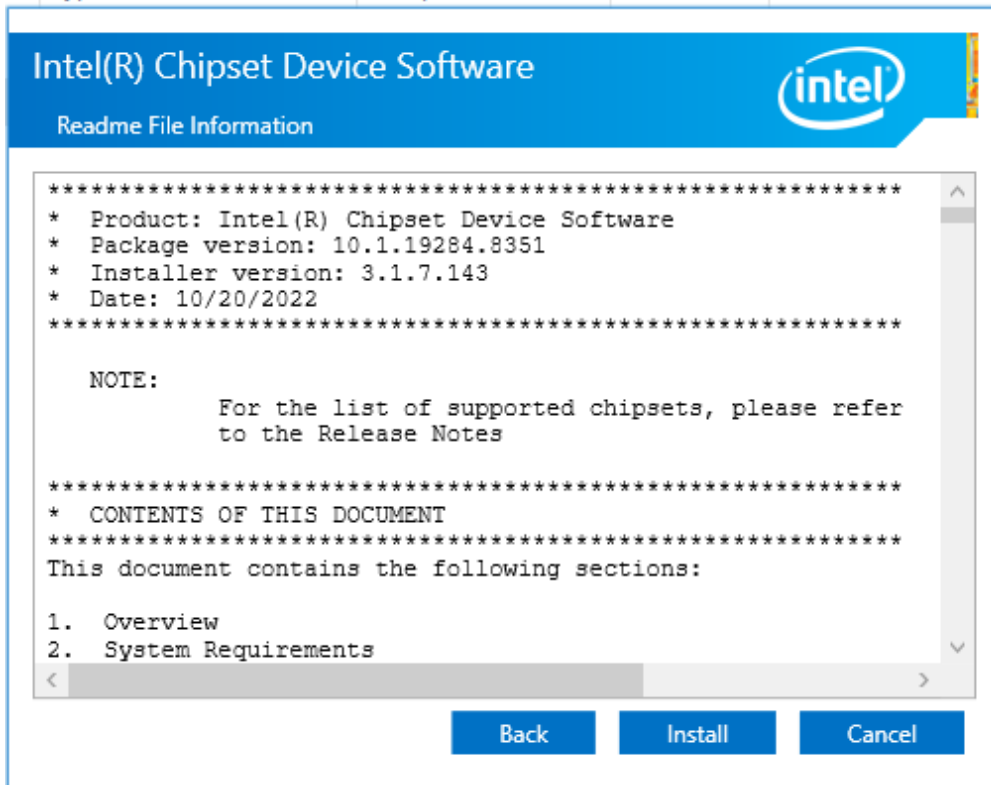

Step 4. Select **Restart Now** to reboot your computer for the changes to take effect.

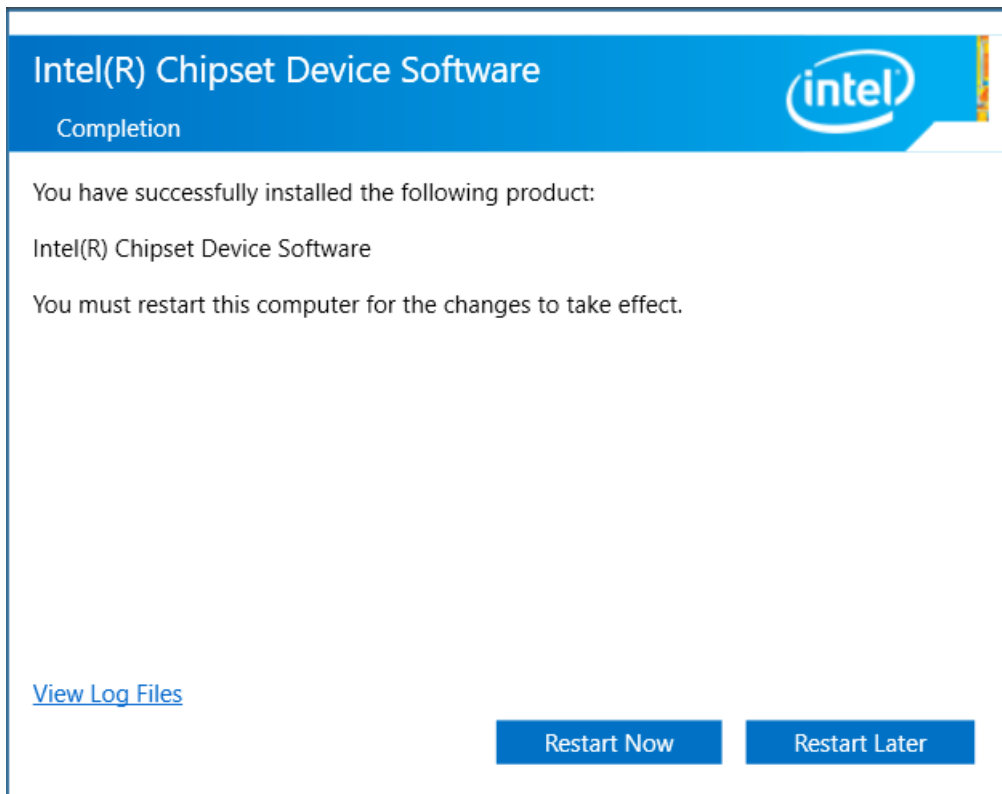

## 4.2 Intel® HD Graphics Chipset

To install the Intel® HD Graphics Chipset, please follow the steps below.

**Step 1.** Click **Begin installation**.



**Step 2.** Read the license agreement. Click **I agree** to accept all the terms of the license agreement.

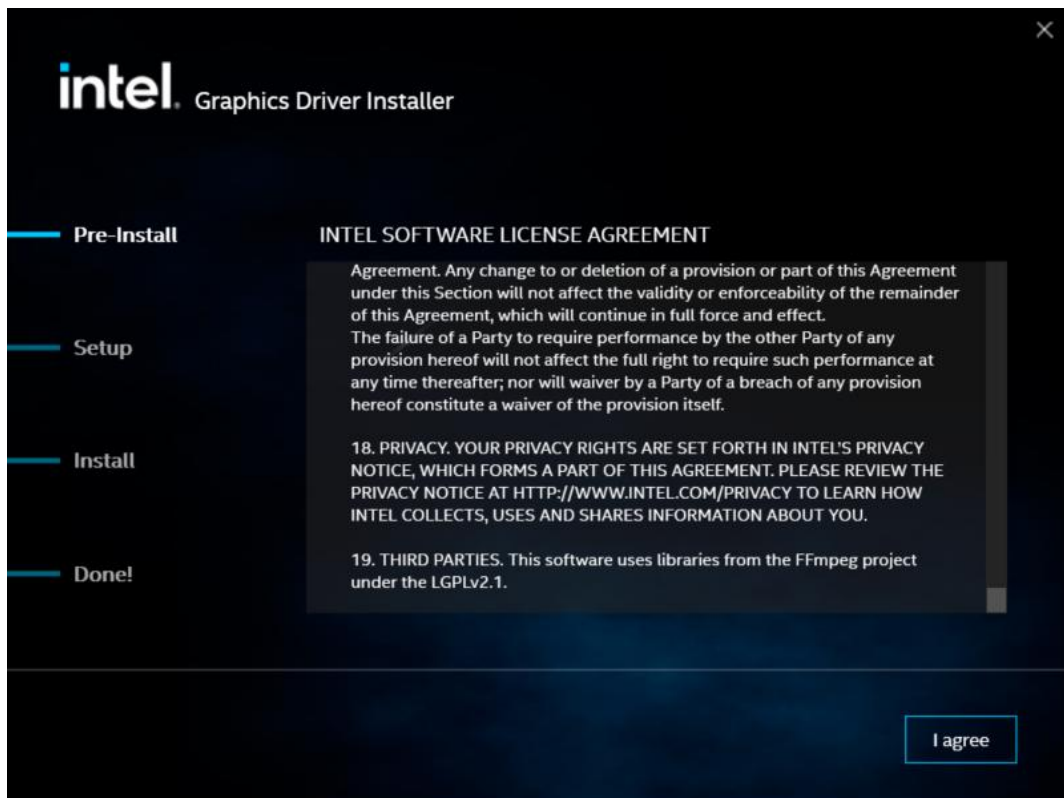

**Step 3.** Choose **Install** function and Click **Start** to setup program.

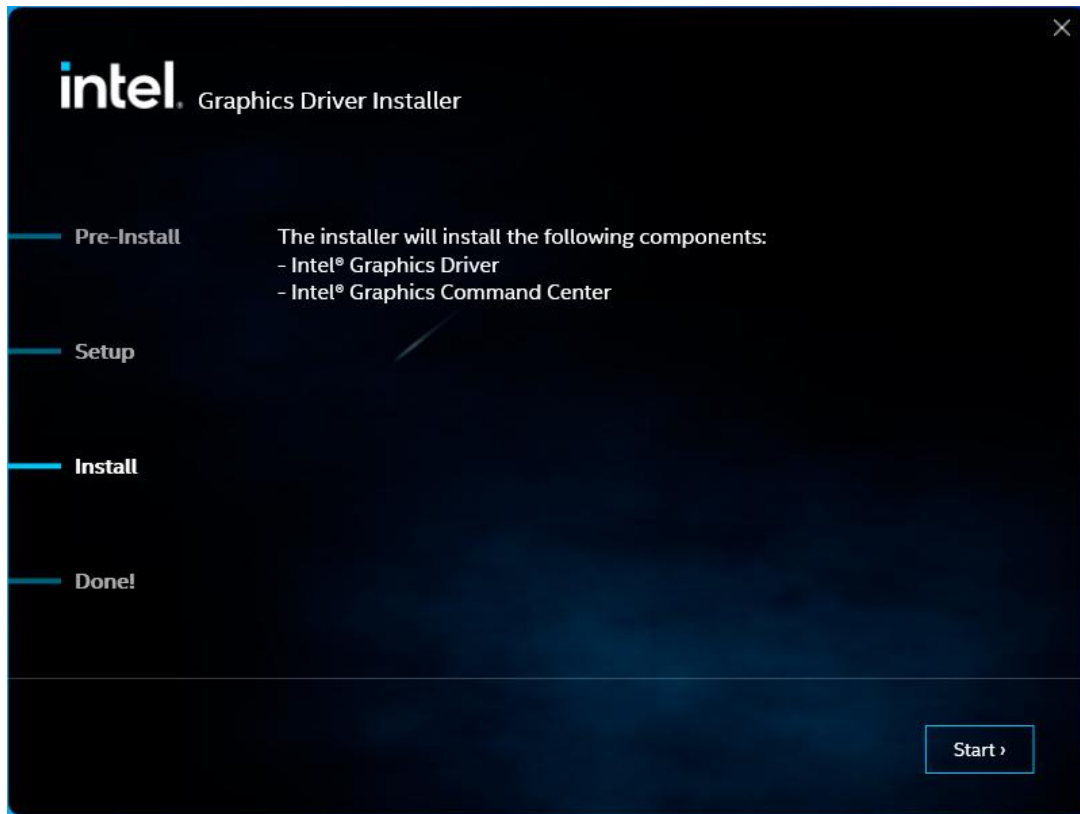

**Step 4.** Click **Finish** to complete installation.

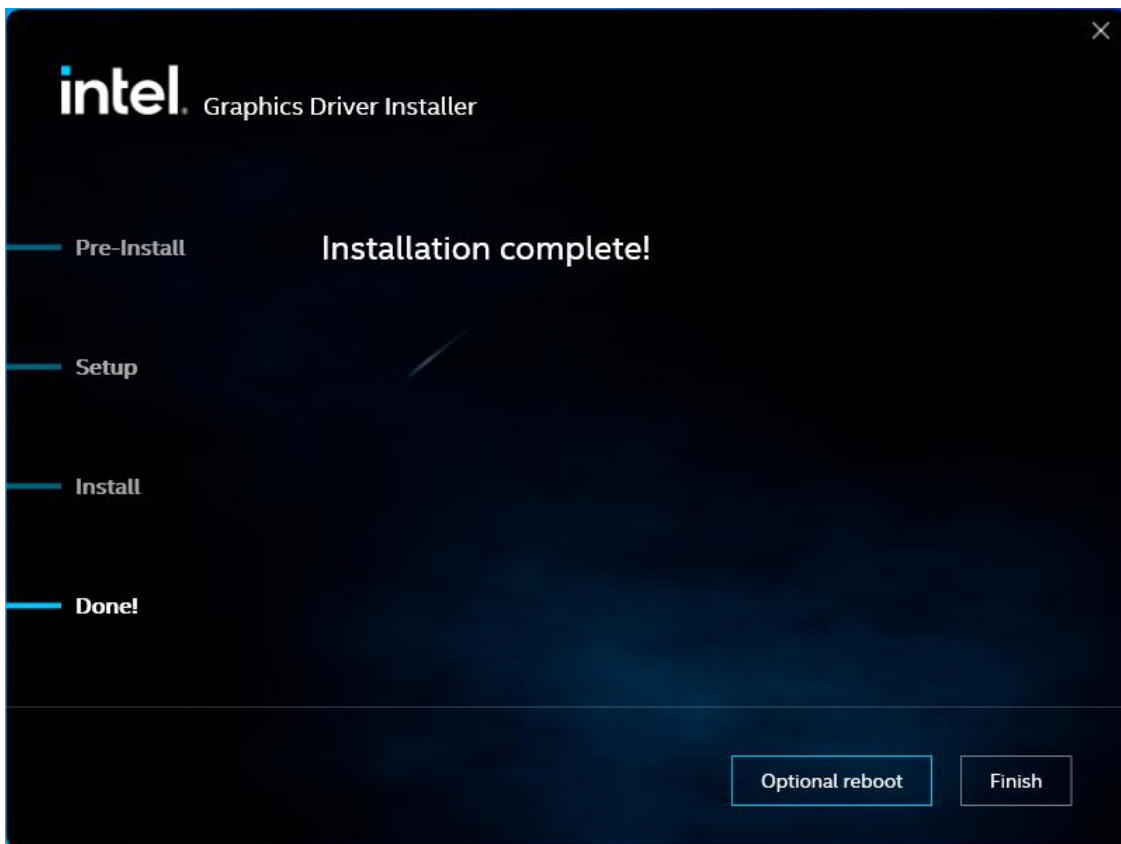

## 4.3 Audio Chipset

To install the Realtek HD Audio Driver, please follow the steps below.

**Step 1.** Click **Next** to continue.

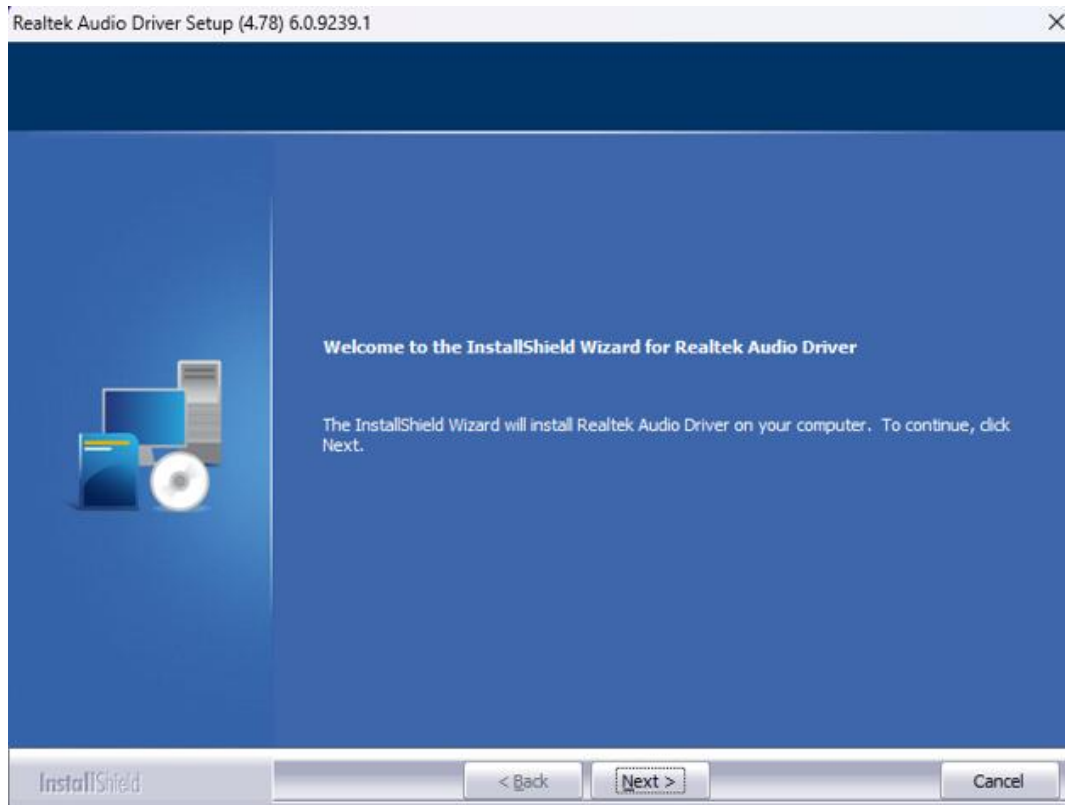

**Step 2.** Click **Yes, I want to restart my computer now.** Click **Finish** to complete the installation.

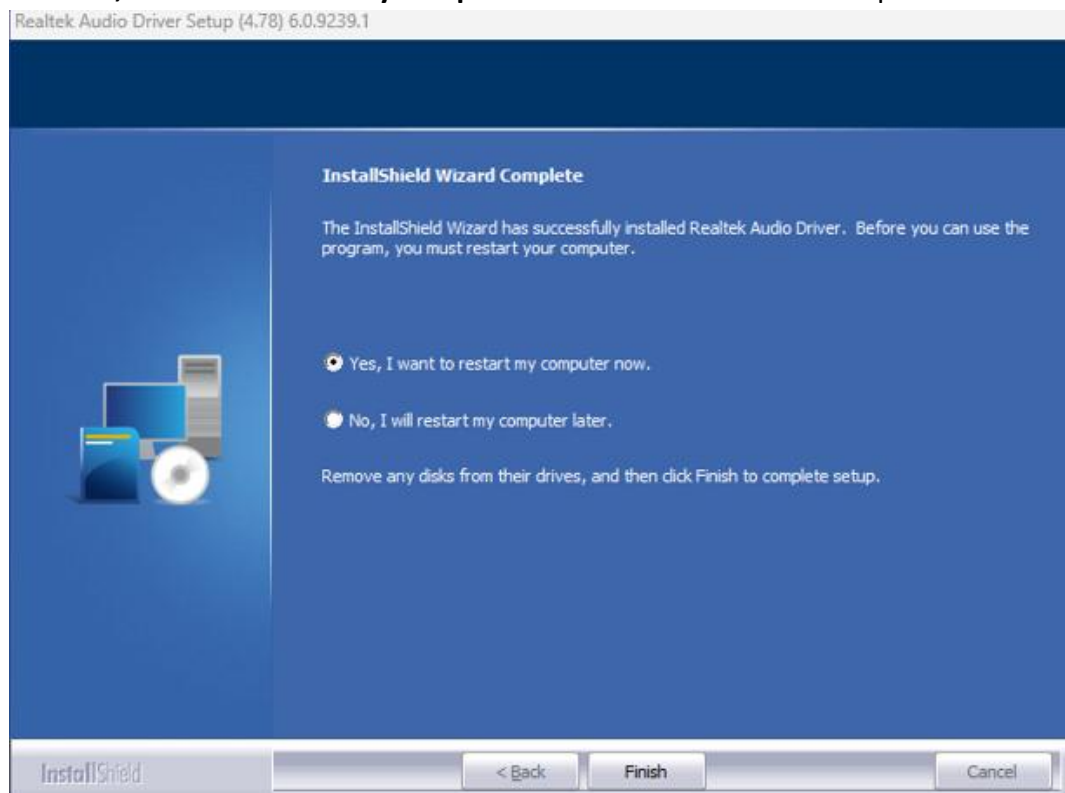

## 4.4 I LAN Driver

To install the LAN driver, please follow the steps below.

**Step 1.** Click **Zip File** to continue.

**Step 2.** Click **OK** to begin the installation.

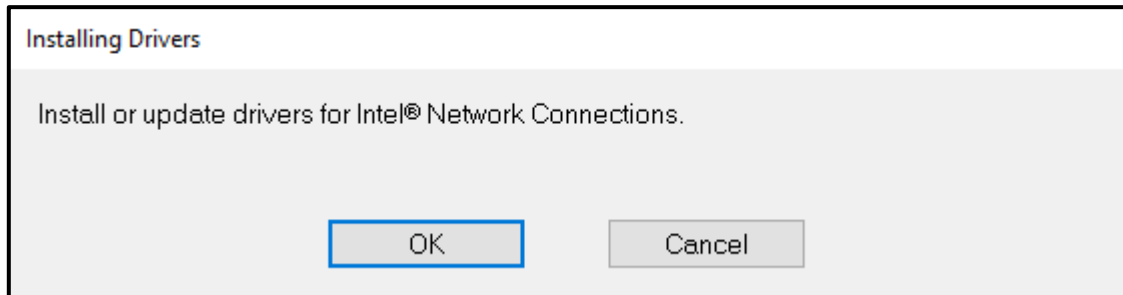

**Step 3.** Click **Close** to finish installation.

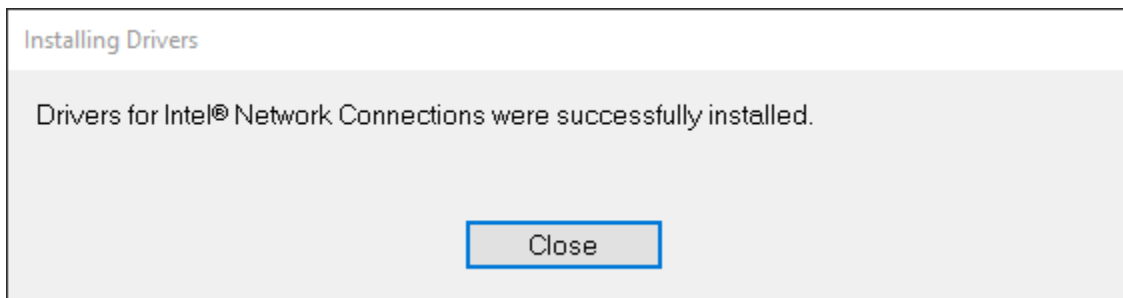

## 4.5 Intel® Management Engine Interface

To install the Intel® Management Engine Interface, please follow the steps below.

**Step 1.** Select setup language you need. Click **Next** to continue.

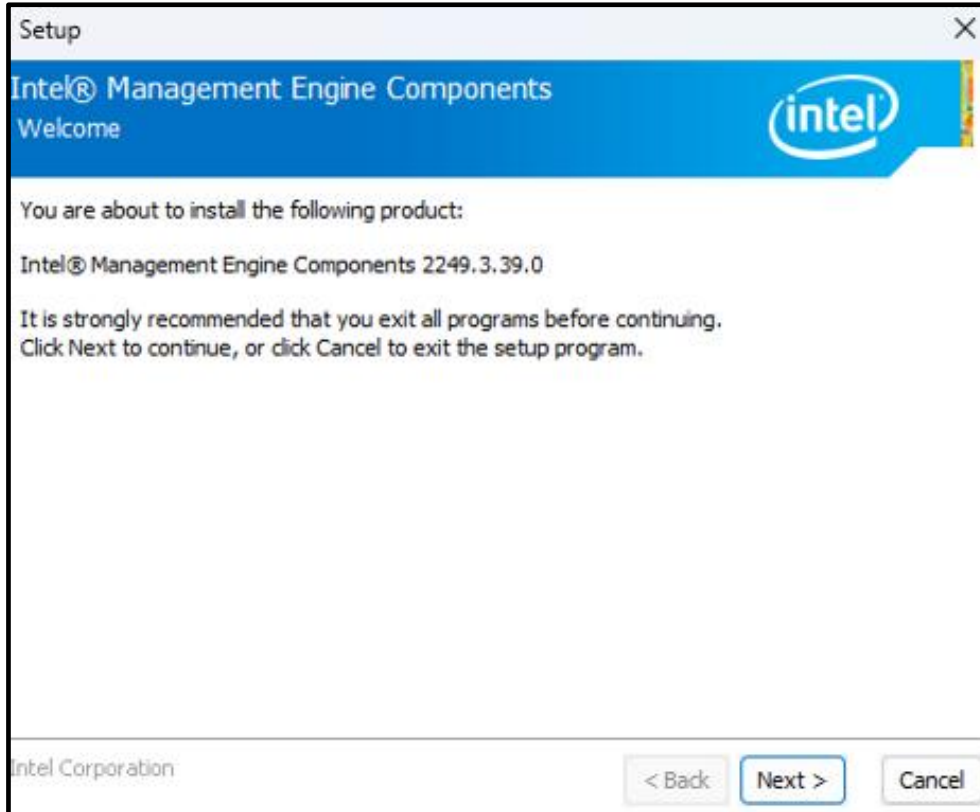

**Step 2.** Choose **I accept the terms in the License Agreement** and click **Next** to begin the installation.

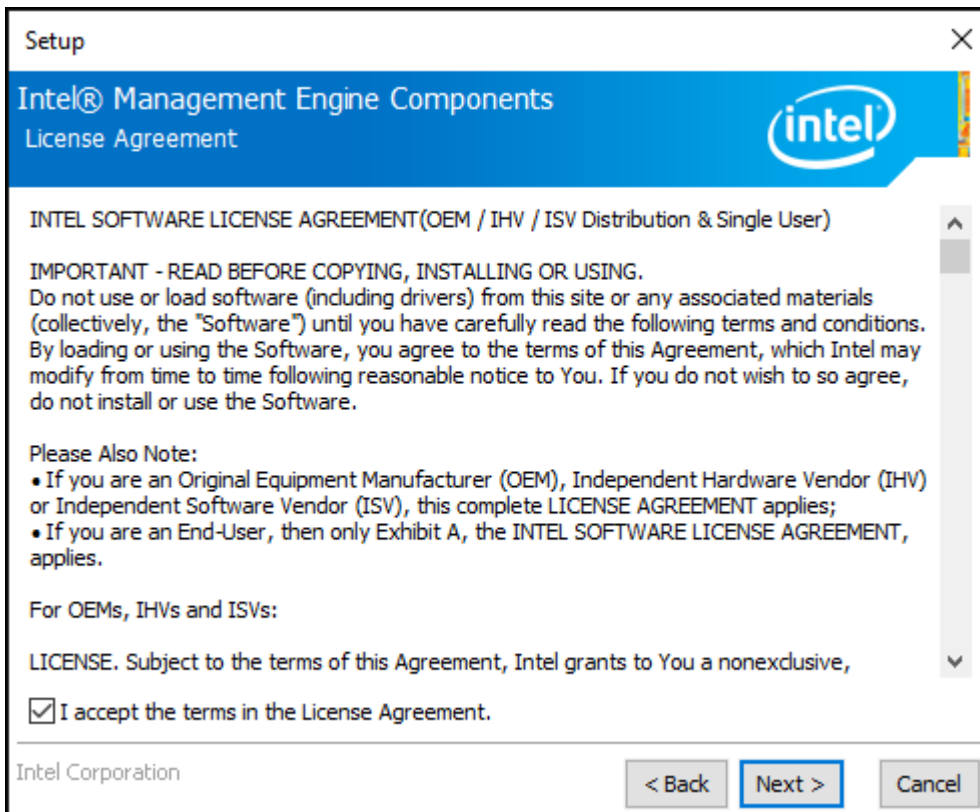

**Step 3.** Click **Next** to continue.

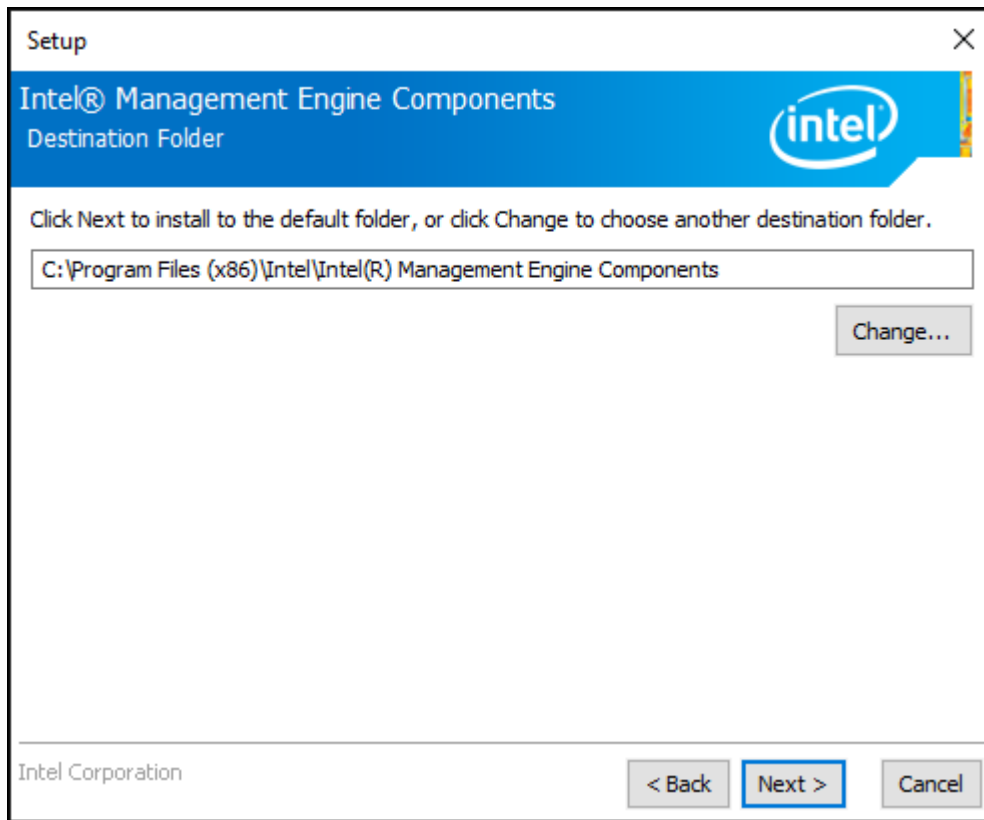

**Step 4.** Click **Finish** to complete the installation.

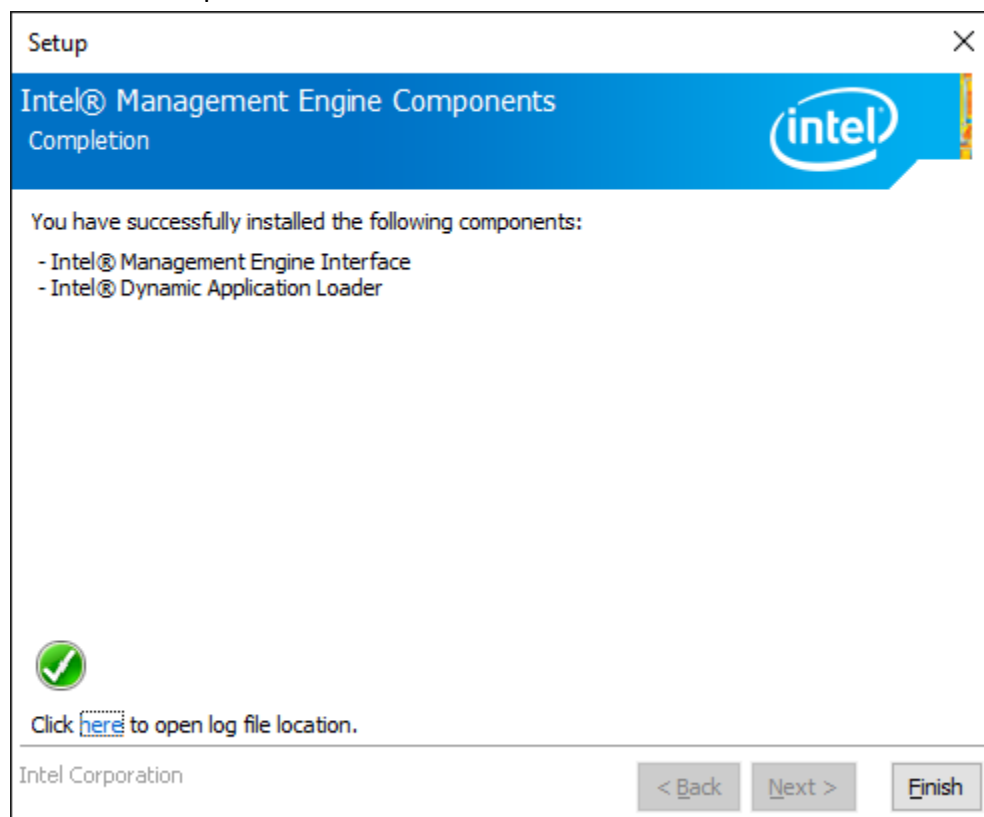

## 4.6 Intel® Speed Select Technology

To install the Intel® Speed Select Technology, please follow the steps below.

**Step 1.** Enable Device Manager under Window and you could see there are exclamation mark on Audio Control, please right click you mouse and pop up an property window, then select “update driver”

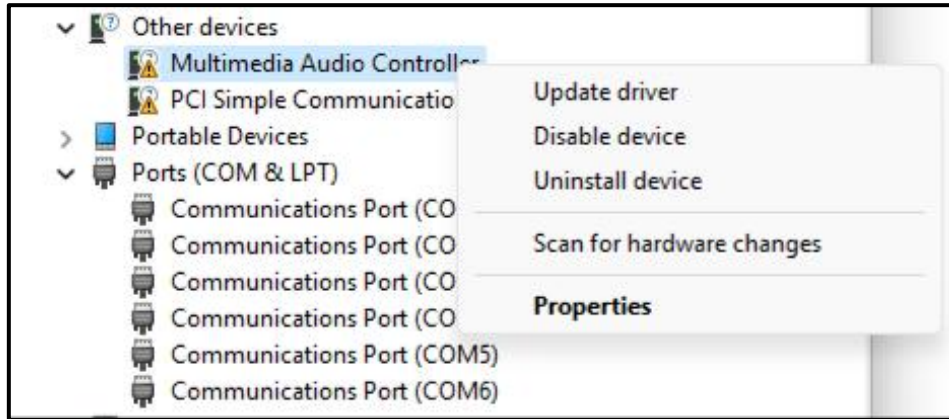

**Step 2.** Select “Browse my computer for drivers” then select driver from your driver folder then install it.

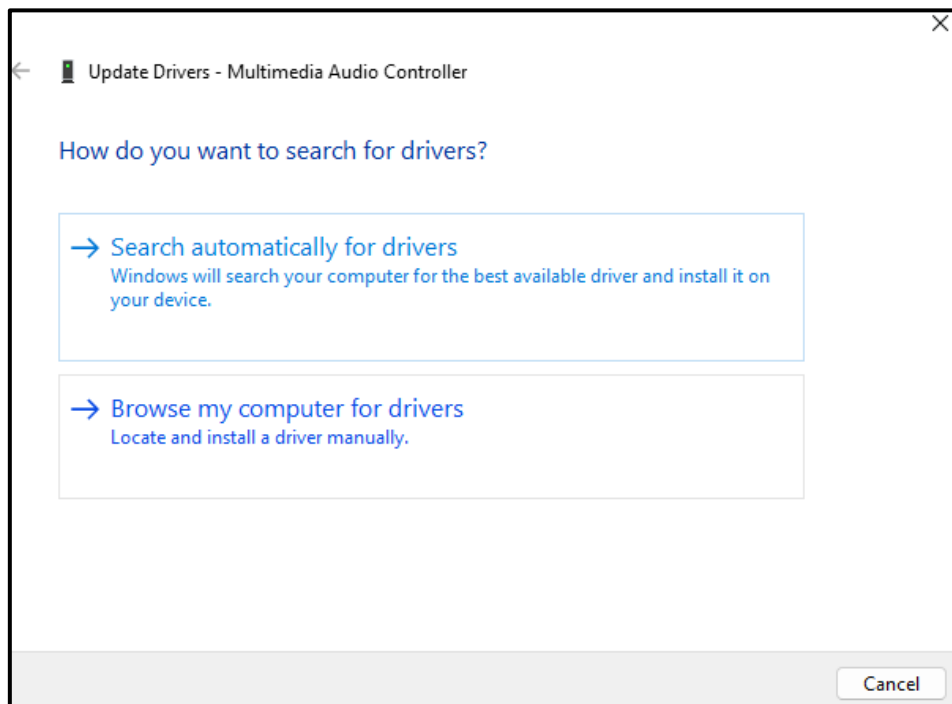

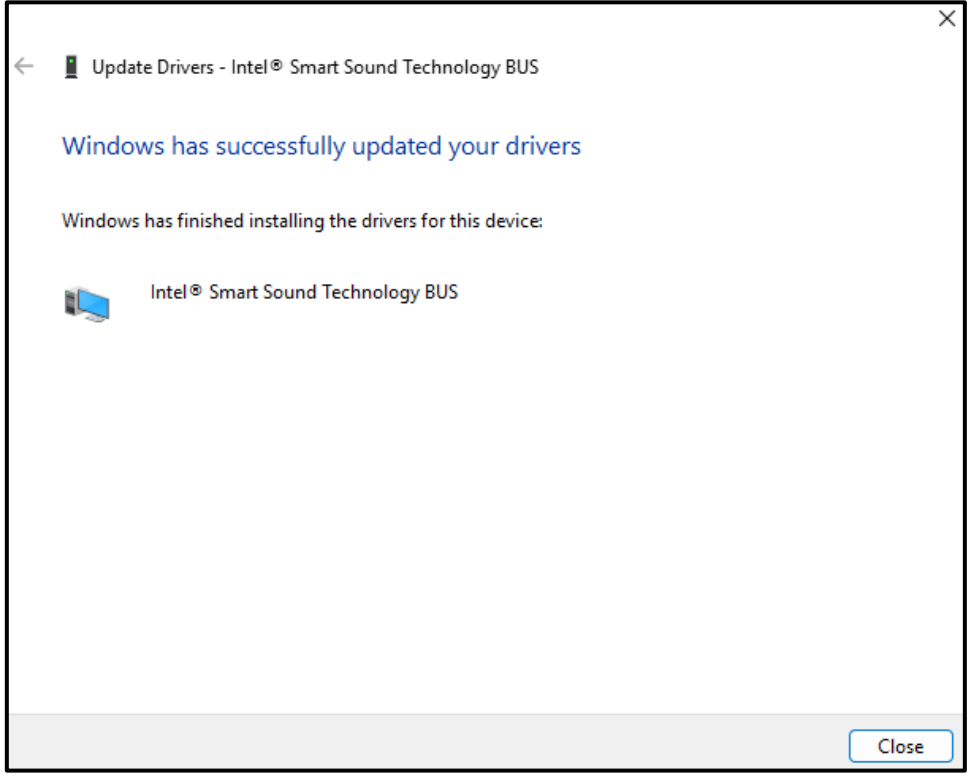
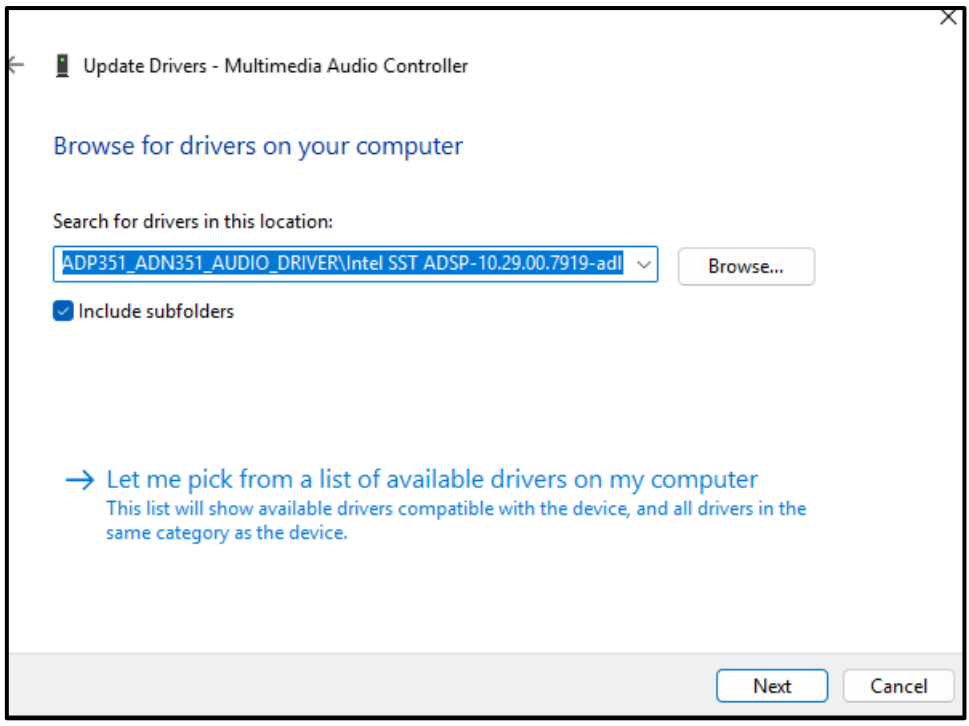

## 4.7 Resistive Touch Screen Installation

This chapter describes how to install drivers and other software that will allow your Resistive touch screen work with different operating systems.

### 4.7.1 Windows 10 Universal Driver Installation for PenMount 6000 Series

Before installing the Windows 10 driver software, you must have the Windows 10 system installed and running on your computer. You must also have one of the following PenMount 6000 series controller or control boards installed: PM6500, PM6300.

### Resistive Touch

If you have an older version of the PenMount Windows 7 driver installed in your system, please remove it first. Follow the steps below to install the PenMount DMC6000 driver.

**Step 1.** Click **Next** to continue.



**Step 2.** Read the license agreement. Click **I Agree** to agree the license agreement.

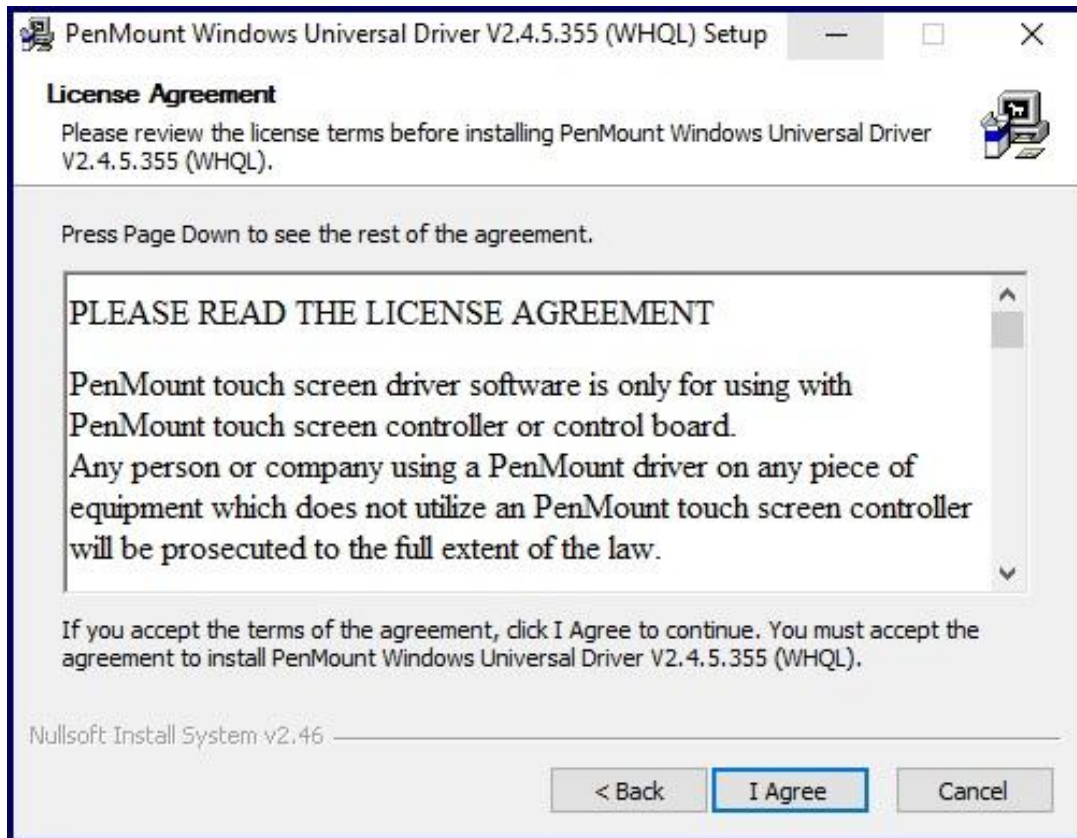

**Step 3.** Choose the folder in which to install PenMount Windows Universal Driver. Click **Install** to start the installation.

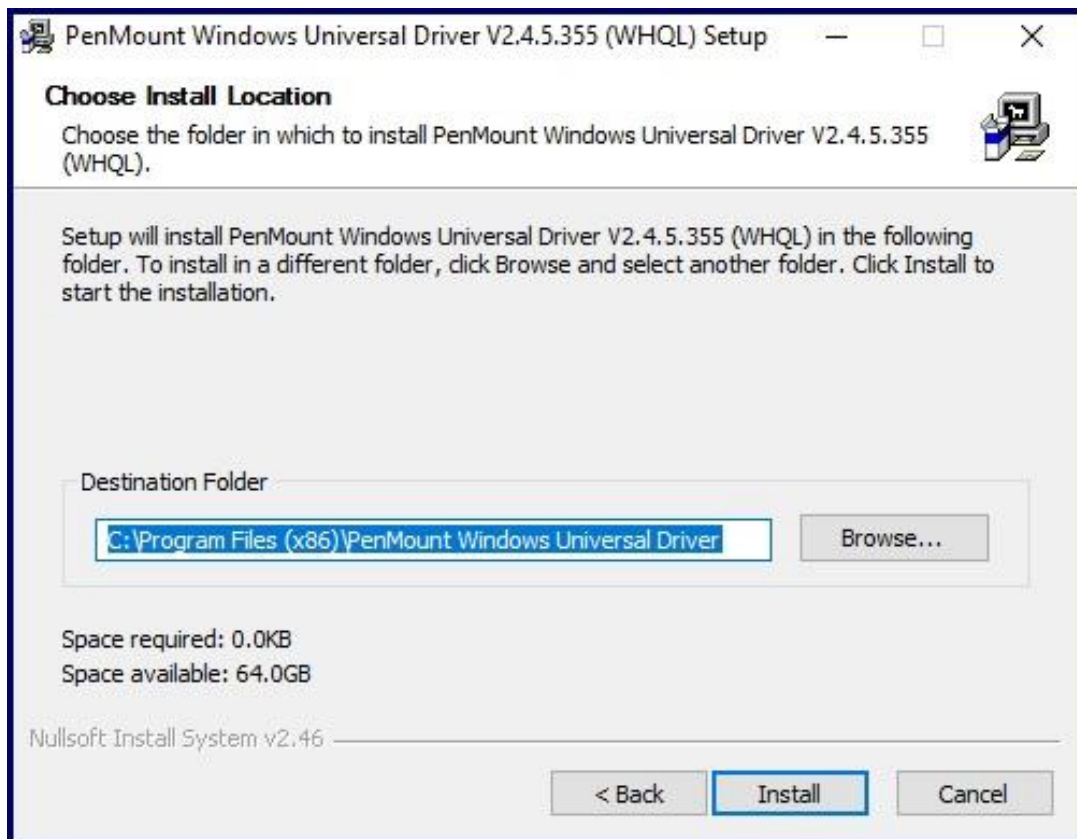

**Step 4.** Click **Yes** to continue.



**Step 5.** Click **Finish** to complete installation.



## 4.7.2 Software Functions

### Resistive Touch

Upon rebooting, the computer automatically finds the new 6000 controller board. The touch screen is connected but not calibrated. Follow the procedures below to carry out calibration.

1. After installation, click the PenMount Monitor icon “PM” in the menu bar.
2. When the PenMount Control Panel appears, select a device to “Calibrate.”

### PenMount Control Panel (Resistive Touch)

The functions of the PenMount Control Panel are **Device**, **Multiple Monitors**, **Tools** and **About**, which are explained in the following sections.

#### Device

In this window, you can find out that how many devices be detected on your system.

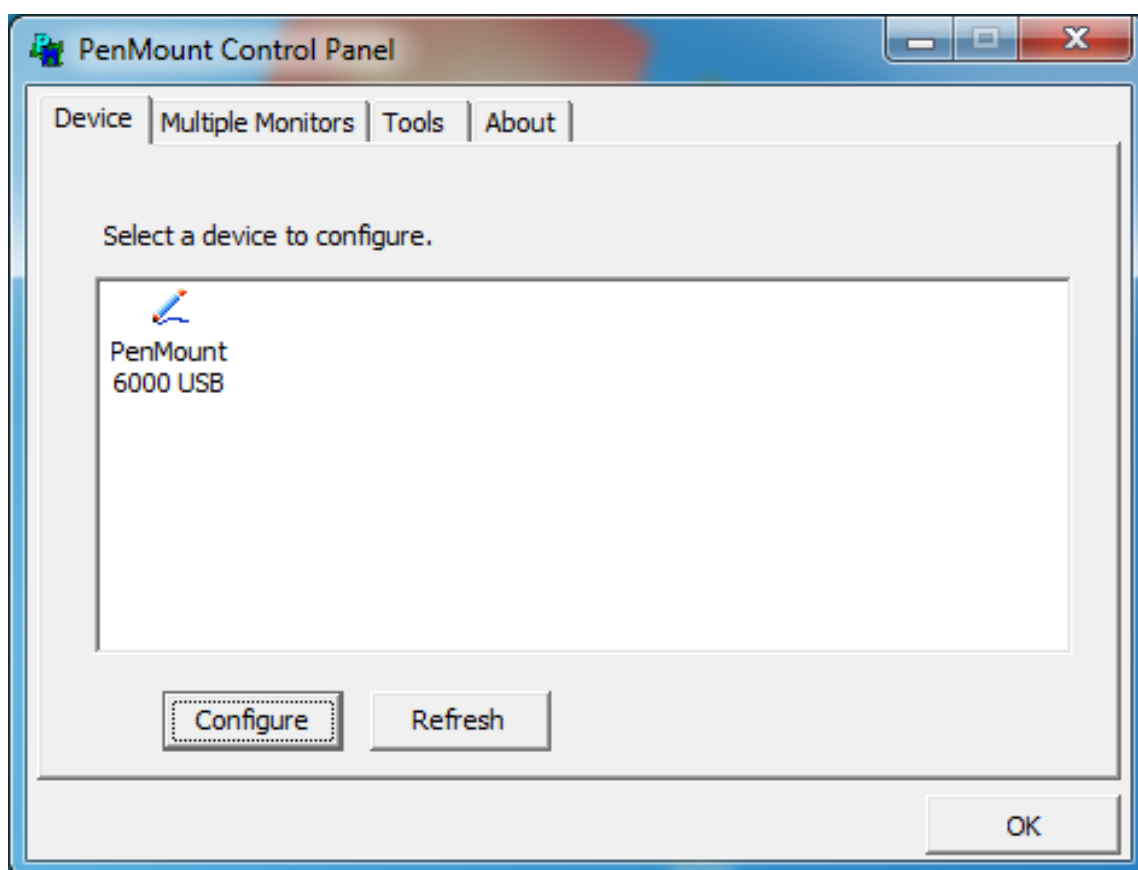

## Calibrate

This function offers two ways to calibrate your touch screen. 'Standard Calibration' adjusts most touch screens. 'Advanced Calibration' adjusts aging touch screens.

Standard Calibration	<b>Click this button and arrows appear pointing to red squares. Use your finger or stylus to touch the red squares in sequence. After the fifth red point calibration is complete. To skip, press 'ESC'.</b>
Advanced Calibration	<b>Advanced Calibration uses 4, 9, 16 or 25 points to effectively calibrate touch panel linearity of aged touch screens. Click this button and touch the red squares in sequence with a stylus. To skip, press ESC'.</b>

**Step 1.** Please select a device then click "Configure". You can also double click the device too.

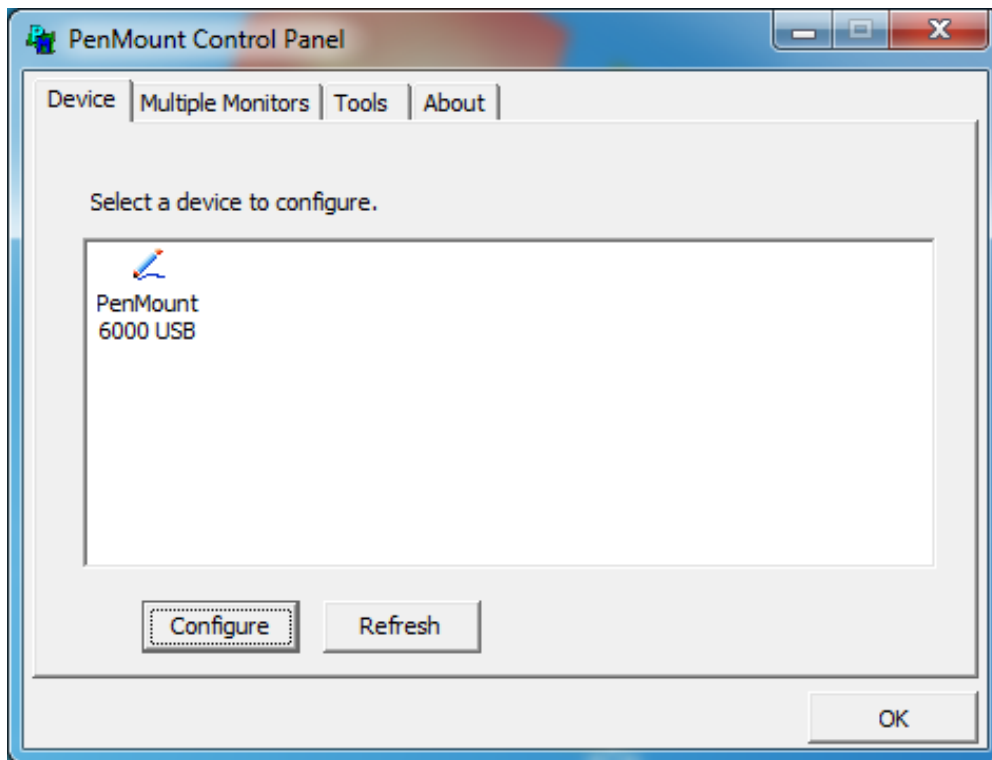

**Step 2.**Click “Standard Calibration” to start calibration procedure

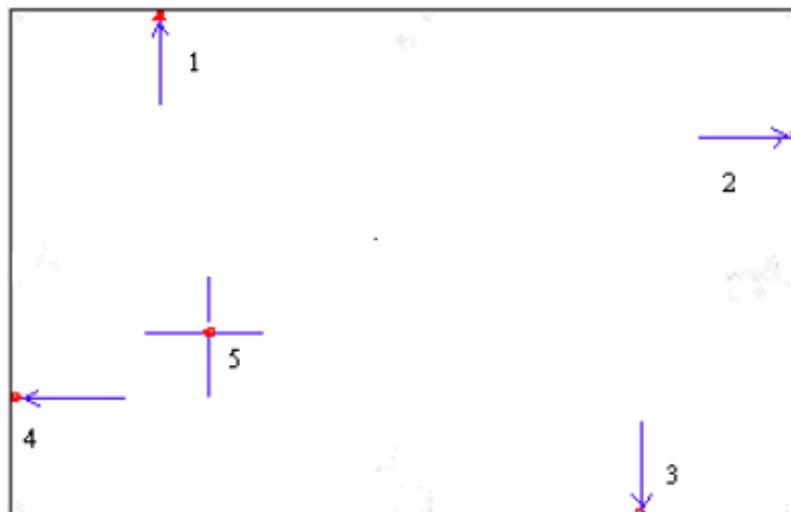
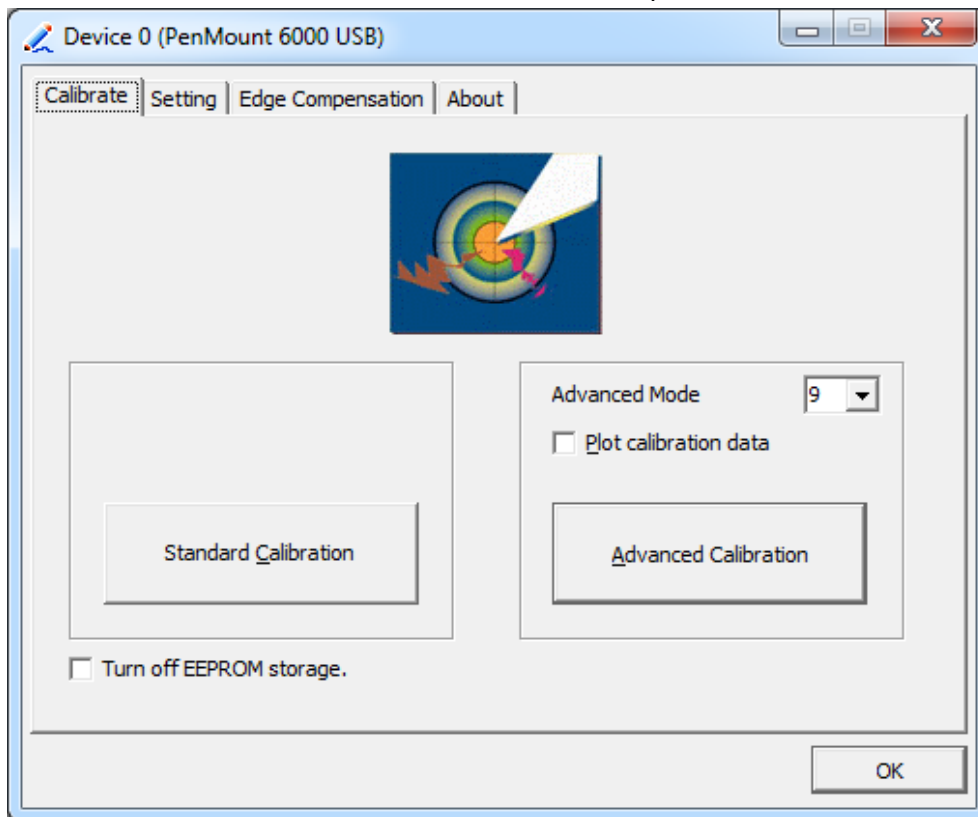

**NOTE:** The older the touch screen, the more Advanced Mode calibration points you need for an accurate calibration. Use a stylus during Advanced Calibration for greater accuracy. Please follow the step as below:

**Step 3.** Select **Device** to calibrate, then you can start to do **Advanced Calibration**.

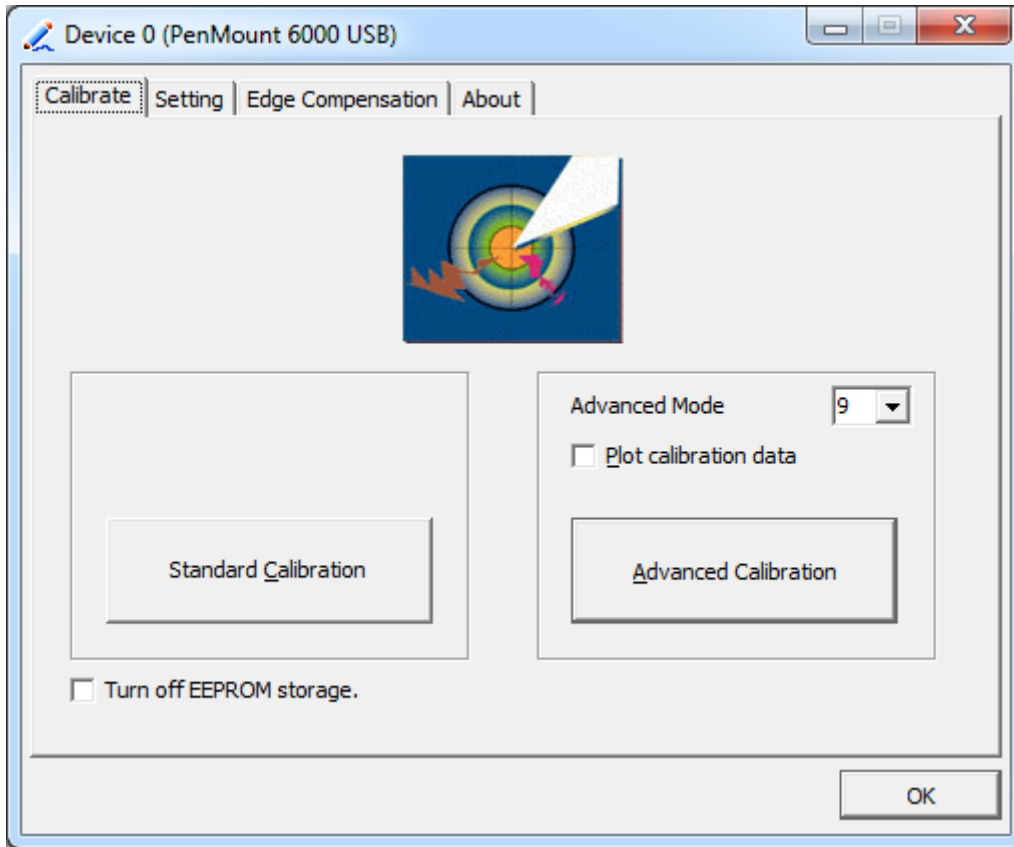

**NOTE:** Recommend to use a stylus during Advanced Calibration for greater accuracy.



Plot Calibration Data	<b>Check this function and a touch panel linearity comparison graph appears when you have finished Advanced Calibration. The blue lines show linearity before calibration and black lines show linearity after calibration.</b>
Turn off EEPROM storage	<b>The function disable for calibration data to write in Controller. The default setting is Enable.</b>

## Setting

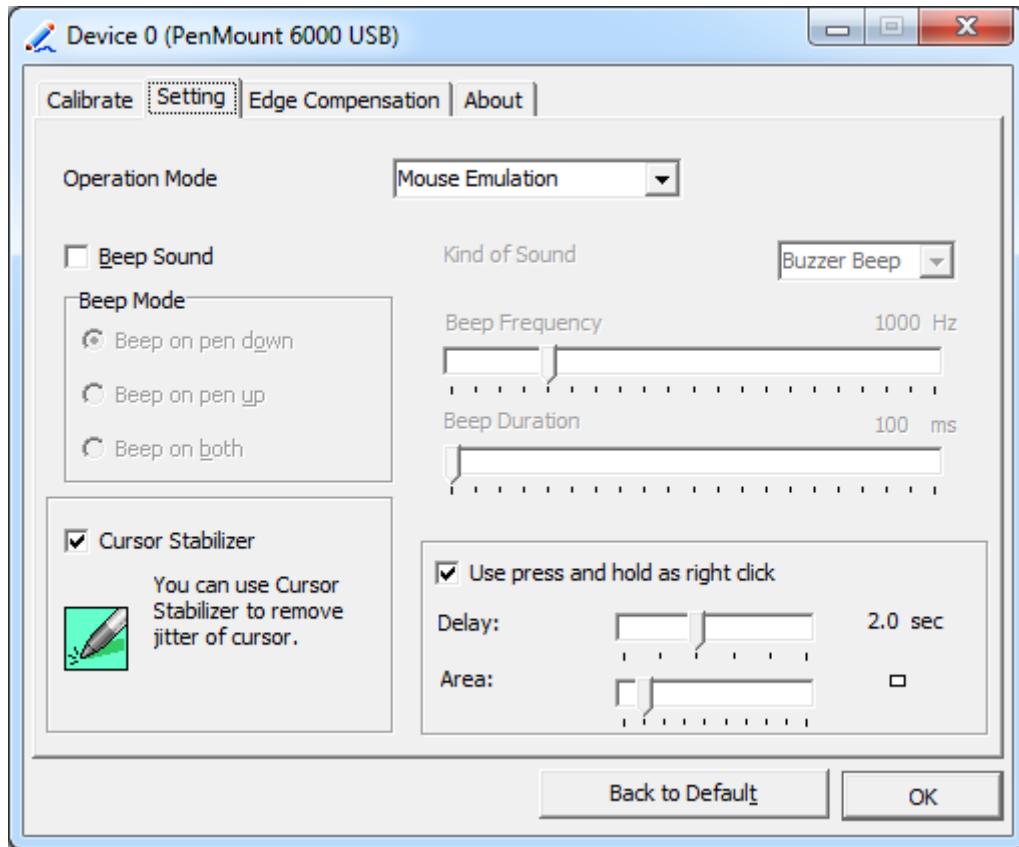

Touch Mode	<p>This mode enables and disables the mouse’s ability to drag on-screen icons – useful for configuring POS terminals.</p> <p><b>Mouse Emulation</b> – Select this mode and the mouse functions as normal and allows dragging of icons.</p> <p><b>Click on Touch</b> – Select this mode and mouse only provides a click function, and dragging is disabled.</p>
Beep Sound	<p><b>Enable Beep Sound</b> – turns beep function on and off</p> <p><b>Beep on Pen Down</b> – beep occurs when pen comes down</p> <p><b>Beep on Pen Up</b> – beep occurs when pen is lifted up</p> <p><b>Beep on both</b> – beep occurs when comes down and lifted up</p> <p><b>Beep Frequency</b> – modifies sound frequency</p> <p><b>Beep Duration</b> – modifies sound duration</p>
Cursor Stabilizer	<p><b>Enable the function support to prevent cursor shake.</b></p>
Use press and hold as right click	<p><b>You can set the time out and area for you need.</b></p>

## Edge Compensation

You can use Edge Compensation to calibrate more subtly.

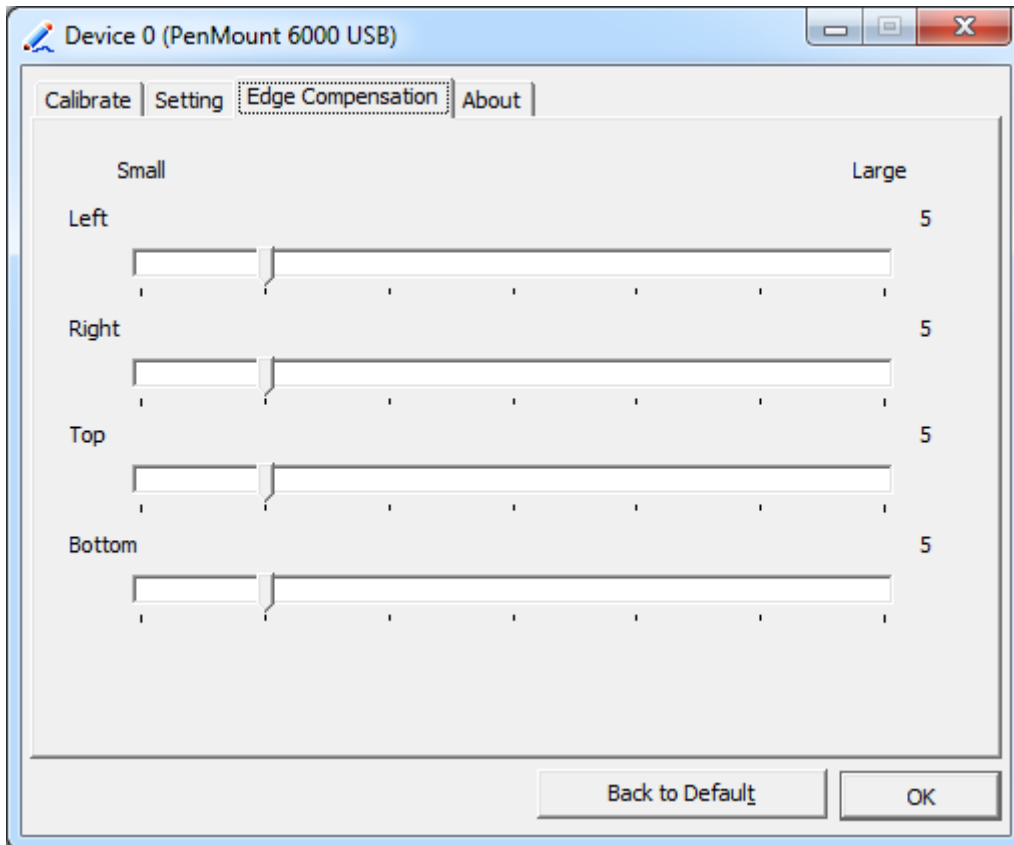

## About

This panel displays information about the PenMount controller and driver version.

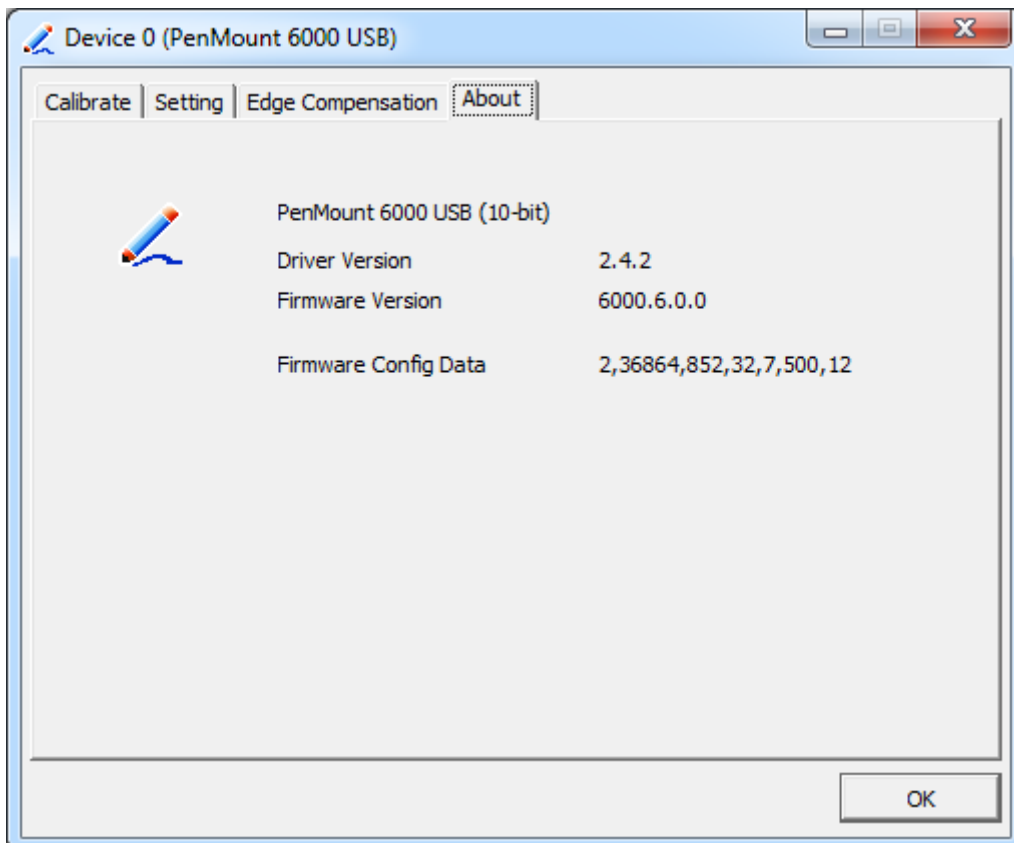

## Multiple Monitors

Multiple Monitors support from two to six touch screen displays for one system. The PenMount drivers for Windows 7/8/8.1 support Multiple Monitors. This function supports from two to six touch screen displays for one system. Each monitor requires its own PenMount touch screen control board, either installed inside the display or in a central unit. The PenMount control boards must be connected to the computer COM ports via the USB interface. Driver installation procedures are the same as for a single monitor. Multiple Monitors support the following modes:  
Windows Extends Monitor Function  
Matrox DualHead Multi-Screen Function  
nVidia nView Function

**NOTE:** The Multiple Monitor function is for use with multiple displays only. Do not use this function if you have only one touch screen display. Please note once you turn on this function the rotating function is disabled.

Enable the multiple display function as follows:

1. Check the **Enable Multiple Monitor Support** box; then click **Map Touch Screens** to assign touch controllers to displays.

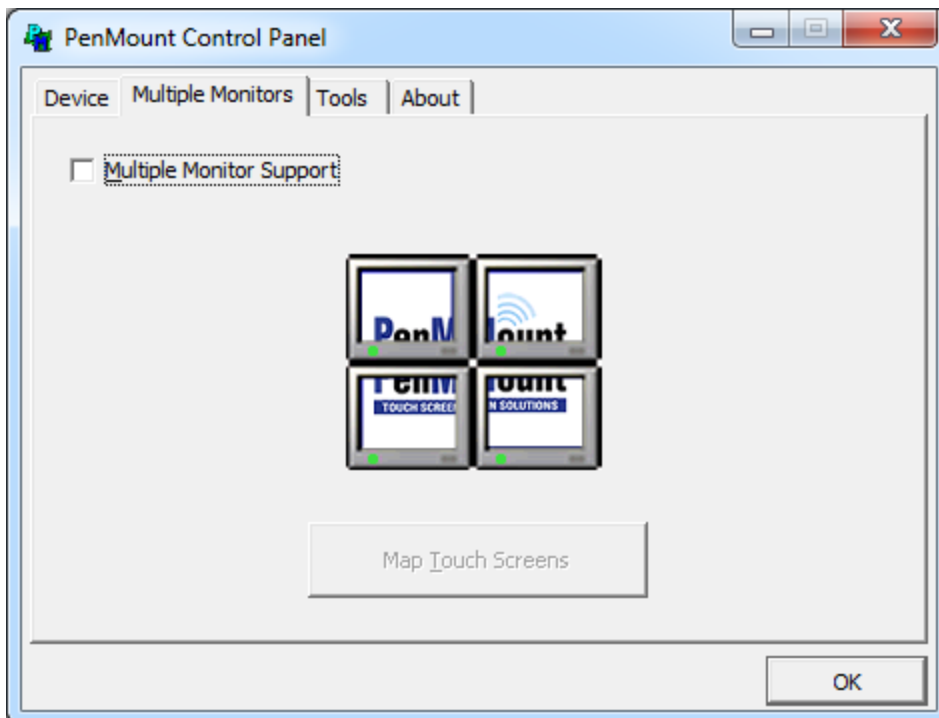

2. When the mapping screen message appears, click **OK**.
3. Touch each screen as it displays “Please touch this monitor”. Following this sequence and touching each screen is called **mapping the touch screens**.



4. Touching all screens completes the mapping and the desktop reappears on the monitors.
5. Select a display and execute the “Calibration” function. A message to start calibration appears. Click **OK**.

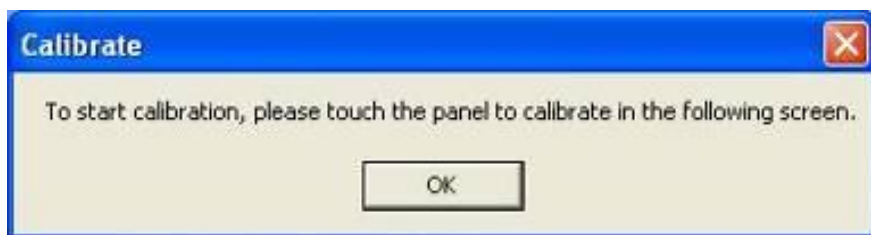

6. “Touch this screen to start its calibration” appears on one of the screens. Touch the screen.
7. “Touch the red square” messages appear. Touch the red squares in sequence.
8. Continue calibration for each monitor by clicking **Standard Calibration** and touching the red squares.

**NOTES:**

1. If you use a single VGA output for multiple monitors, please do not use the **Multiple Monitor** function. Just follow the regular procedure for calibration on each of your desktop monitors.
2. The Rotating function is disabled if you use the Multiple Monitor function.
3. If you change the resolution of display or screen address, you have to redo **Map Touch Screens**, so the system understands where the displays are.

## About

This panel displays information about the PenMount controller and this driver version.

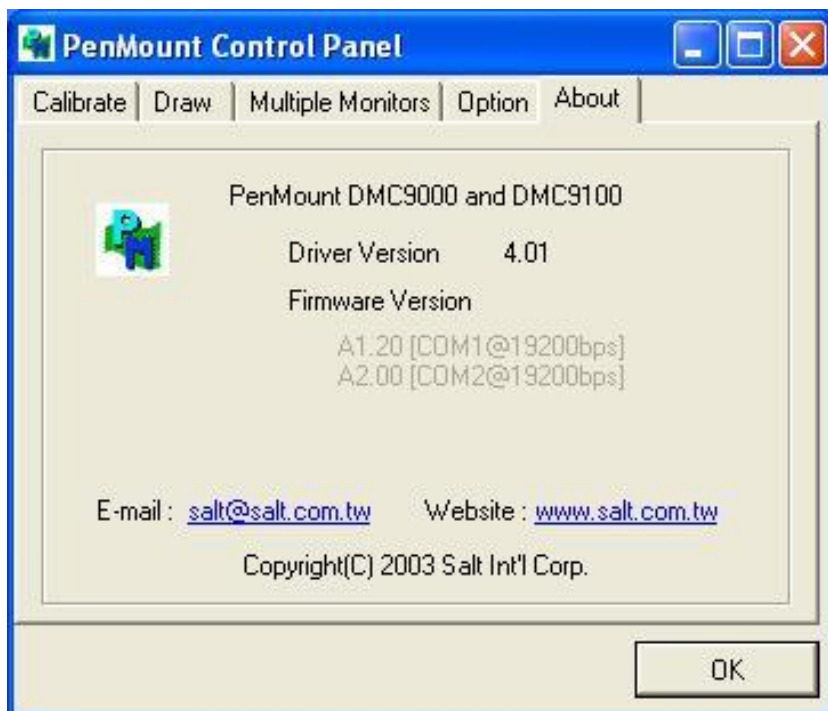

### PenMount Monitor Menu Icon

The PenMount monitor icon (PM) appears in the menu bar of Windows 7/8/8.1 system when you turn on PenMount Monitor in PenMount Utilities.



PenMount Monitor has the following function



Control Panel	<b>Open Control Panel Windows</b>
Beep	<b>Setting Beep function for each device</b>
Right Button	<p><b>When you select this function, a mouse icon appears in the right-bottom of the screen.</b></p> <p><b>Click this icon to switch between Right and Left Button functions.</b></p> 
Exit	<b>Exits the PenMount Monitor function.</b>

### Configuring the Rotate Function

1. Install the rotation software package.
2. Choose the rotate function (0°, 90°, 180°, 270°) in the 3rd party software. The calibration screen appears automatically. Touch this point and rotation is mapped.

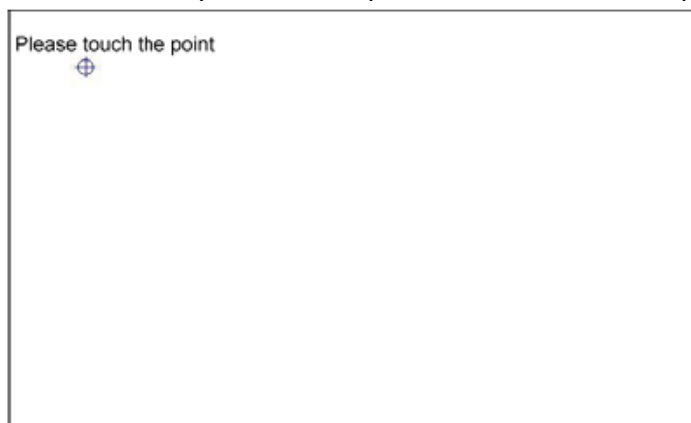

**NOTE:** The Rotate function is disabled if you use Monitor Mapping